

# E SERIES

## Hydronic Heat Pumps

- R-410A Refrigerant
- 2 thru 5 Ton

[Design Features](#)

[Factory Options](#)

[Accessories](#)

[Dimensional Data](#)

[Physical Data](#)

[Performance Data](#)

[Engineering Guide Specifications](#)



# E SERIES



WaterFurnace E Series Hydronic Heat Pumps set the industry standard for efficiency, flexibility, performance, reliability, and quiet operation. Available in four sizes (EW020, 030, 042, 060), the wide range of operating temperatures, compact size, reversible control box and water piping enable the EW product to be used in a wide variety of applications including pool/spa heating, radiant floor, fan coils, snow melt, aquaculture, and process water installations.

EW units can be selected as heating only or heating/cooling models (except the EW020, which is heating only). The modularized unit design and primary/secondary controls enable optimum capacity matching and staging. A sophisticated microprocessor controls the load loop pump, source loop pump and compressor by sampling the entering load side water temperature. The controller enables the user to view all modes of operation and easily adjust setpoint temperatures. All fault conditions are monitored by the controller to ensure safe, reliable operation. The EW unit cabinet is fabricated from heavy-gauge steel and finished with a corrosion-resistant polyester coating to provide years of durability and beauty. As for efficiency, Scroll compressors, R-410A refrigerant, and oversized heat exchangers combine to provide the user with exceptional energy savings.

EW Series Hydronic Heat Pumps are safety listed with ETL.

As a leader in the industry, WaterFurnace is dedicated to innovation, quality and customer satisfaction. In fact, every unit built is exposed to a wide range of quality control procedures throughout the assembly process and is then subjected to a rigorous battery of computerized run tests to certify that it meets or exceeds performance standards for efficiency and safety, and will perform flawlessly at startup. As further affirmation of our quality standards, each unit carries our exclusive Quality Assurance emblem, signed by the final test technician.

WaterFurnace International's corporate headquarters and manufacturing facility is located in Fort Wayne, IN. A scenic three-acre pond located in front of the building serves as our geothermal heating and cooling source to comfort-condition our 110,000 square feet of manufacturing and office space. As a pioneer, and now a leader in the industry, the team of WaterFurnace engineers, customer support staff and skilled assembly technicians is dedicated to providing the finest comfort systems available.

By choosing or specifying E Series Hydronic Heat Pumps, you can be assured that your customer is investing in an exceptional system that will provide energy savings and safe, reliable operation for many years to come. That's because WaterFurnace is indeed "*Smarter from the Ground Up.*"

# Table of Contents

<b>Model Nomenclature</b>	<b>4</b>
<b>Design Features</b>	<b>5</b>
<b>Physical Elements</b>	<b>6</b>
<b>Dimensional Data</b>	<b>6</b>
<b>Physical Data</b>	<b>6</b>
<b>Electrical Data</b>	<b>7</b>
<b>Control Panel &amp; Configuration</b>	<b>8-9</b>
<b>Performance Summary</b>	<b>10</b>
<b>Water Flow and Pressure Drop</b>	<b>11-12</b>
<b>Reference Calculations</b>	<b>13</b>
<b>Legends and Notes</b>	<b>13</b>
<b>Capacity Data</b>	<b>14-20</b>
<b>Accessories and Other Options</b>	<b>21-22</b>
<b>Engineering Guide Specifications</b>	<b>23</b>

# Model Nomenclature

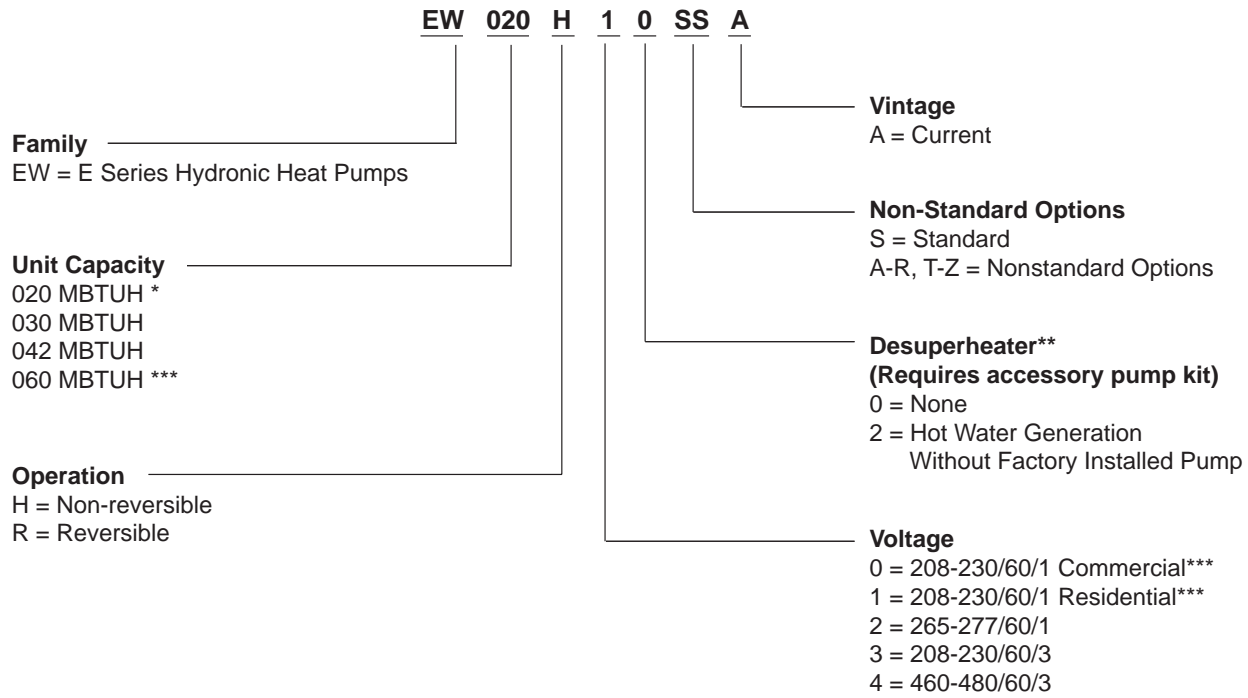

**Notes:** \* EW020 is a heating only unit; vented coax is standard, no options.

\*\* Available on 042 and 060 only.

\*\*\* EW060 is not rated for 208/60/1 volt operation.

# Design Features

## Application Flexibility

- Designed to operate with leaving liquid temperatures of 30°F to 130°F [-1°C to 54°C] 30°F to 100°F [-1°C to 38°C] Evap. LWT, 60°F to 130°F [16°C to 54°C] Cond. LWT.
- Source side flow rates as low as 1.5 GPM/ton for well water, 50°F [10°C] min. EWT.
- Dedicated heating and heat pump models available.
- Dedicated non-reversible models are shipped as heating only; field convertible to cooling only.
- Modularized unit design and primary/secondary controls for optimum capacity matching and staging.
- Stackable for space conservation (to a maximum 3 units high).
- Compact size allows installation in confined spaces.
- Front or rear plumbing connections.
- Control Panel location is reversible.

## Operating Efficiencies

- Environmentally friendly R-410A refrigerant reduces ozone depletion.
- An optional desuperheater is available on EW042 and EW060 to generate hot water at considerable savings while improving overall system efficiency.
- High-stability bi-directional expansion valve provides superior performance.
- Efficient scroll compressors operate quietly.
- Oversized coaxial tube water-to-refrigerant heat exchanger increases efficiency.

## Service Advantages

- Removable access panels provide quick access to all internal components.
- Integrated temperature controls with digital readout and user interface.
- High- and low-pressure service ports in refrigerant circuit.

## Factory Quality

- Heavy-gauge steel cabinets are finished with a durable polyester powder coat paint for long lasting beauty and service.
- The front access panel of each unit, as well as the top of the EW020, is made of a high-density non-metallic material.
- All refrigerant brazing is performed in a nitrogen atmosphere.
- All units are deep evacuated to less than 150 microns prior to refrigerant charging.
- All joints are helium leak-tested to ensure annual leak rate of less than 1/4 ounce [28.34g] per year.
- The vented double coaxial in the EW020 is copper with all other coaxials constructed of cupronickel.
- Coaxial heat exchangers, refrigerant suction lines, desuperheater coil and all water pipes are fully insulated to reduce condensation problems in low temperature operation.
- Sound attenuation features include an isolation mounted compressor and high density weighted sound blanket.
- Safety features include high- and low-pressure refrigerant controls to protect the compressor; hot water high-limit desuperheater pump shutdown.

## Options & Accessories

- Optional desuperheater with externally mounted pump and water heater plumbing connector.
- Closed loop, source side, circulating pump kit.
- Closed loop, load side, circulating pump kit.
- Water connection kits
- (Refer to pages 24-25.)

# Physical Elements

Figure 1: Front and Back Physical Elements

## Back View

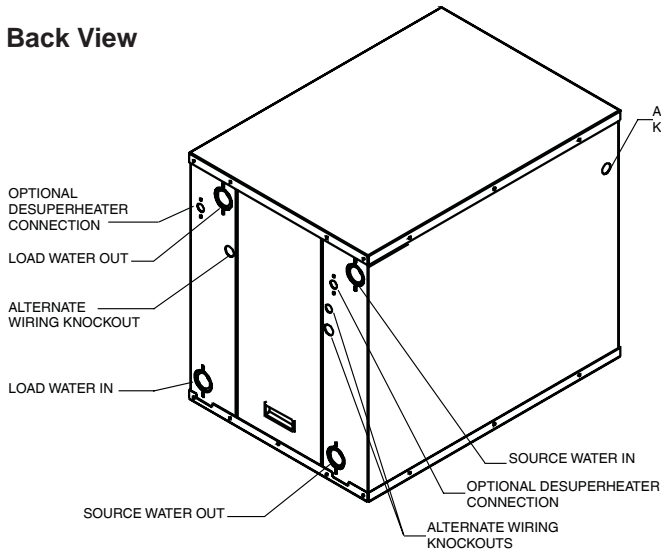

## Front View

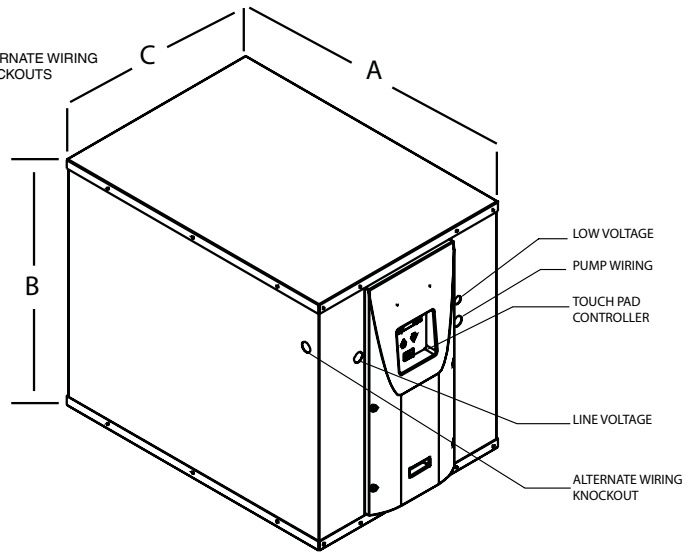

## Dimensional Data

MODEL	A in [cm]	B in [cm]	C in [cm]	Load Liquid in FPT in [cm]	Load Liquid Out FPT in [cm]	Source Liquid Out FPT in [cm]	Source Liquid In FPT in [cm]	Desuperheater In FPT in [cm]	Desuperheater Out FPT in [cm]
EW020	25.5 [64.8]	26.3 [66.8]	18.0 [45.7]	1.00 [2.54]	1.00 [2.54]	1.00 [2.54]	1.00 [2.54]	-	-
EW030	32.5 [82.6]	26.3 [66.8]	22.0 [55.9]	1.00 [2.54]	1.00 [2.54]	1.00 [2.54]	1.00 [2.54]	-	-
EW042	32.5 [82.6]	26.3 [66.8]	22.0 [55.9]	1.00 [2.54]	1.00 [2.54]	1.00 [2.54]	1.00 [2.54]	0.50 [1.27]	0.50 [1.27]
EW060	32.5 [82.6]	26.3 [66.8]	22.0 [55.9]	1.00 [2.54]	1.00 [2.54]	1.00 [2.54]	1.00 [2.54]	0.50 [1.27]	0.50 [1.27]

Rev. 11/06

## Physical Data

	EW020	EW030	EW042H	EW042R	EW060H	EW060R
Compressor	Scroll	Scroll	Scroll	Scroll	Scroll	Scroll
Refrigerant Charge	50.0 [1.42]	64.0 [1.81]	79.0 [2.24]	85.0 [2.41]	90.0 [2.55]	90.0 [2.55]
Unit Weight	202 [91.6]	265 [120.2]	325 [147.4]	325 [147.8]	360 [163.3]	360 [163.8]

Notes: Refrigerant charge – oz, [kg]  
Unit weight – lbs, [kg]

Rev. 4/06

# Electrical Data

UNIT	RATED VOLTAGE	VOLTAGE MIN/MAX	COMPRESSOR		LOAD PUMP	SOURCE PUMP	TOTAL UNIT FLA	MIN CKT AMP	MAX FUSE	MAX CKT BRK
			RLA	LRA						
EW020	208-230/60/1	197/254	13.5	61.0	0.41	5.4	19.3	22.7	35	35
	265/1	239/292	10.9	58.0	-	-	10.9	13.6	20	20
	460/60/3	414/506	4.5	27.0	-	-	4.5	5.6	10	10
EW030	208-230/60/1	197/254	15.4	83.0	1.8	5.4	22.6	26.5	40	40
	265/60/1	239/292	15.4	83.0	-	-	15.4	19.3	30	30
	208-230/60/3	197/254	11.5	77.0	-	-	11.5	14.4	25	25
	460/60/3	414/506	5.1	35.0	-	-	5.1	6.4	10	10
EW042	208-230/60/1	197/254	26.9	145.0	1.8	5.4	34.1	40.8	60	60
	265/60/1	239/292	24.3	157.0	-	-	24.3	30.4	50	50
	208-230/60/3	197/254	17.6	123.0	-	-	17.6	22.0	35	35
	460/60/3	414/506	7.7	49.5	-	-	7.7	9.6	15	15
EW060	230/60/1	207/254	32	148.0	1.8	5.4	39.2	47.2	70	70
	265/60/1	239/292	20.2	160.0	-	-	20.2	25.3	45	45
	208-230/60/3	197/254	22.4	156.0	-	-	22.4	28.0	50	50
	460/60/3	414/506	10.6	75.0	-	-	10.6	13.3	20	20

**Notes:** All fuses are type "D" time delay (or HACR circuit breaker in USA). Source pump amps shown are for up to a 1/2 HP pump. Load pump amps shown are for small circulators. EW060 is not rated for 208/60/1 operation.

Rev. 4/06

## Control Panel

The control panel allows you to access the service menu on the unit. The control panel has three 7-segment LED screens that display the:

- Water temperature
- Configuration menu

There are 6 LED indicators that indicate when the SECONDARY OUTPUT is active or the unit is on one of the following modes:

- Standby Mode
- Heating Mode
- Cooling Mode
- Primary (Master) Mode

The control panel has both UP and DOWN (arrow) buttons and a MODE button. The UP and DOWN buttons allow you to change the set point or scroll through the configuration menu. The MODE button allow you to change mode as well as enter and exit parameters while in configuration mode.

**Figure 2: Control Panel**

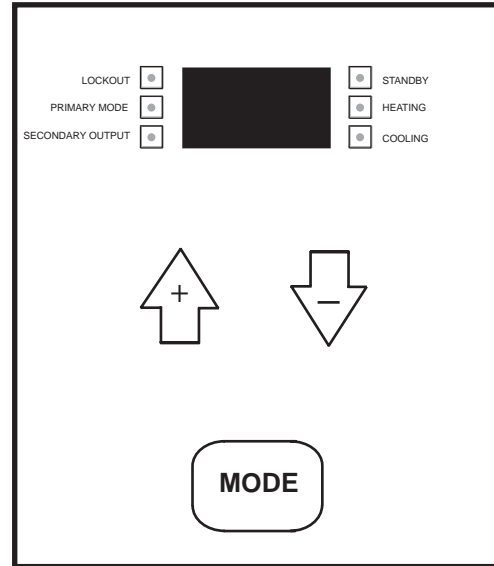

## Control Panel Configuration

The configuration menu allows you to properly set and adjust all of the unit's operating parameters to fit your application. To enter configuration mode and configure parameters, follow these procedures:

1. Hold down both the UP and DOWN buttons simultaneously for five seconds, or until the LED screen displays "LC".
2. Press the UP or DOWN arrow until "50" is displayed.
3. Press the MODE button. The screen should display "SC" to indicate the controller is in configuration mode.
4. Once in configuration mode, press the UP or DOWN arrow to scroll through the menu.
5. Press the MODE button to enter the parameter. (Refer to the parameter table below for a list of configurable parameters.)
6. Once in the parameter, press the UP or DOWN arrow to change the parameter.
7. Press the MODE button to return to the main menu.

**Note:** The controller will exit the configuration mode after 30 seconds if no key is pressed.

# Control Panel Configuration (cont.)

## Parameter Functions and Set-

PARAMETER	FUNCTION	DESCRIPTION	FACTORY SETTING	RANGE	INCREMENTS
<b>SC</b>	Calibrate the Water Sensor	This will allow the temperature displayed to be adjusted to match a temperature reading from an external source.	0	-9 to 10	1
<b>dB</b>	Dead Band	This parameter is used to determine when the compressor should be activated. If the set point is below the set point minus the dB value (in heating mode) then the compressor will activate.	1	1 to 15	1
<b>CF</b>	Celsius/ Fahrenheit Selection	This parameter selects the units for which the temperature will be displayed.	F	F or C	N/A
<b>FP</b>	Freeze Protection Setting	There are three settings for this parameter; OL, CL, and P. OL is the open loop setting which corresponds to 30°F (0°C). CL is the closed loop setting which is 15°F (-10°C). P is the process setting which is 5°F (-15°C).	OL	P,CL,OL	N/A
<b>SL</b>	Primary/ Secondary Setting	Primary mode utilizes an internal aquastat to determine the activity of the compressor. In secondary mode the compressor output is determined by an external aquastat	0 (Primary)	0 or 1	0 = Primary 1 = Secondary
<b>IC</b>	Initial Condition	This parameter is used to determine the state of the secondary output of the primary unit. If the actual water temperature is greater than the IC value away from the set point, the secondary output will be activated.	10	0 to 20	1
<b>d</b>	Derivative	This parameter is used to determine the state of the secondary output of the primary and secondary unit. If the change in temperature is less than the "d" value the secondary output will activate.	1	0 to 5	1
<b>P</b>	Period	This determines how often the derivative will be calculated.	5 min	1 to 5 min	1 min
<b>PS</b>	Pump Sampling Time Selection	This parameter determines how long the pump is activated before the controller takes a sample of the water temperature. The range of this parameter is from 1 to 5 minutes and is factory set to 3 minutes. The pump can also be set to run continuously when PS is set to C.	3 min	1 to 5 min or C	1 min
<b>Fd</b>	Freeze Protection Display	This displays the current temperature of the freeze protection sensor.	N/A	0 to 130	N/A

# Performance Summary

## Heating Capacity Data

MODEL	SOURCE						LOAD						CAPACITY		COP
	FLOW			SWPD			FLOW			LWPD			HEAT OUTPUT	kW	
	EWT	GPM	L/s	PSI	FT HD	BAR	EWT	GPM	L/s	PSI	FT HD	BAR			
EW020	32	6	0.38	4.3	9.9	0.3	104	3	0.19	1.2	2.8	0.1	22.2	6.5	2.8
	32	9	0.57	9.0	20.8	0.6	104	9	0.57	9	20.8	0.6	22.5	6.6	3.0
EW030	32	8	0.50	2.8	6.5	0.2	104	5	0.32	1.4	3.2	0.1	29.0	8.5	3.0
	32	12	0.76	5.6	12.9	0.4	104	12	0.76	5.6	12.9	0.4	29.5	8.6	3.1
EW042	32	11	0.69	2.5	5.8	0.2	104	7	0.44	1.2	2.8	0.1	44.9	13.2	2.9
	32	16.5	1.04	5.6	12.9	0.4	104	16.5	1.04	5.6	12.9	0.4	45.5	13.3	3.0
EW060*	32	14	0.88	2.7	6.2	0.2	104	11	0.69	1.8	4.2	0.1	59.2	17.4	2.8
	32	21	1.32	5.7	13.2	0.4	104	21	1.32	5.7	13.2	0.4	60.7	17.8	3.0

**Notes:** Based on 60 Hz., single phase. For more detailed data, refer to pages 14-20.

\* For 3 phase EW060 capacity, multiply above data by .948. For 3 phase EW060 power, multiply above data by .943.

## Cooling Capacity Data

MODEL	SOURCE						LOAD						CAPACITY		EER
	FLOW			SWPD			FLOW			LWPD			MBTU	kW	
	EWT	GPM	L/s	PSI	FT HD	BAR	EWT	GPM	L/s	PSI	FT HD	BAR			
EW030R	77	8	0.50	2.8	6.5	0.2	53.6	8.0	0.50	2.8	6.5	0.2	21.9	6.42	10.67
	77	12	0.76	5.6	12.9	0.4	53.6	12.0	0.76	5.6	12.9	0.4	22.1	6.48	10.93
EW042R	77	11	0.69	2.5	5.8	0.2	53.6	11.0	0.69	2.5	5.8	0.2	42.7	12.51	12.42
	77	16.5	1.04	5.6	12.9	0.4	53.6	16.5	1.04	5.6	12.9	0.4	43.2	12.66	12.86
EW060R*	77	14	0.88	2.7	6.2	0.2	53.6	14.0	0.88	2.7	6.2	0.2	58.0	17.00	12.54
	77	21	1.32	5.7	13.2	0.4	53.6	21.0	1.32	5.7	13.2	0.4	61.1	17.91	13.47

**Notes:** Based on 60 Hz., single phase. For more detailed data, refer to pages 14-20.

\* For 3 phase EW060R capacity, multiply above data by .948. For 3 phase EW060R power, multiply above data by .943.

## Flow Rates and Pressure Drop

The following tables list the required minimum flow rates (GPM) for all combinations of source temperatures from 30°F to 110°F [-1°C to 43°C] and load temperatures from 100°F to 130°F [38°C to 54°C]. For example, on an EW020, heating water to a temperature of 125°F [52°C] with a 70°F [21°C] source temperature requires a minimum flow of 3.5 GPM. Refer to the tables on page 12 for required source side flow rates.



**WARNING:** Operating the unit outside of the minimum flow rate parameters will trip the high pressure switch and/or result in compressor damage.

### EW020 Minimum Load Flow

SOURCE EWT	MAX HEATING SET POINT													
	100°F		105°F		110°F		115°F		120°F		125°F		130°F	
	GPM	WPD	GPM	WPD	GPM	WPD	GPM	WPD	GPM	WPD	GPM	WPD	GPM	WPD
30°F	1.5	0.3	1.5	0.3	1.5	0.3	1.5	0.3	1.5	0.3	1.5	0.3	2.0	0.6
40°F	1.5	0.3	1.5	0.3	1.5	0.3	1.5	0.3	1.5	0.3	2.0	0.6	2.5	0.8
50°F	1.5	0.3	1.5	0.3	1.5	0.3	1.5	0.3	2.0	0.6	2.5	0.8	3.0	1.2
60°F	1.5	0.3	1.5	0.3	1.5	0.3	2.0	0.6	2.5	0.8	3.0	1.2	3.5	1.6
70°F	1.5	0.3	1.5	0.3	2.0	0.6	2.5	0.8	3.0	1.2	3.5	1.6	4.0	2.0
80°F	1.5	0.3	2.0	0.6	2.5	0.8	3.0	1.2	3.5	1.6	4.0	2.0	6.0	4.3
90°F	2.0	0.6	2.5	0.8	3.0	1.2	3.5	1.6	4.0	2.0	6.0	4.3	7.0	5.7
100°F	2.5	0.8	3.0	1.2	3.5	1.6	4.0	2.0	6.0	4.3	7.0	5.7	7.5	6.4
110°F	3.0	1.2	3.5	1.6	4.0	2.0	6.0	4.3	7.0	5.7	7.5	6.4	9.0	9.0

### EW030 Minimum Load Flow

SOURCE EWT	MAX HEATING SET POINT													
	100°F		105°F		110°F		115°F		120°F		125°F		130°F	
	GPM	WPD	GPM	WPD	GPM	WPD	GPM	WPD	GPM	WPD	GPM	WPD	GPM	WPD
30°F	2.5	0.3	2.5	0.3	2.5	0.3	2.5	0.3	2.5	0.3	2.5	0.3	3.0	0.5
40°F	2.5	0.3	2.5	0.3	2.5	0.3	2.5	0.3	2.5	0.3	3.0	0.5	3.5	0.8
50°F	2.5	0.3	2.5	0.3	2.5	0.3	2.5	0.3	3.0	0.5	3.5	0.8	4.5	1.0
60°F	2.5	0.3	2.5	0.3	2.5	0.3	3.0	0.5	3.5	0.8	4.5	1.0	5.5	1.4
70°F	2.5	0.3	2.5	0.3	3.0	0.5	3.5	0.8	4.5	1.0	5.5	1.4	6.5	2.0
80°F	2.5	0.3	3.0	0.5	3.5	0.8	4.5	1.0	5.5	1.4	6.5	2.0	9.0	3.6
90°F	3.0	0.5	3.5	0.8	4.5	1.0	5.5	1.4	6.5	2.0	9.0	3.6	11.0	5.2
100°F	3.5	0.8	4.5	1.0	5.5	1.4	6.5	2.0	9.0	3.6	11.0	5.2	11.5	5.6
110°F	4.5	1.0	5.5	1.4	6.5	2.0	9.0	3.6	11.0	5.2	11.5	5.6		

### EW042 Minimum Load Flow

SOURCE EWT	MAX HEATING SET POINT													
	100°F		105°F		110°F		115°F		120°F		125°F		130°F	
	GPM	WPD	GPM	WPD	GPM	WPD	GPM	WPD	GPM	WPD	GPM	WPD	GPM	WPD
30°F	3.5	0.3	3.5	0.3	3.5	0.3	3.5	0.3	3.5	0.3	3.5	0.3	4.5	0.5
40°F	3.5	0.3	3.5	0.3	3.5	0.3	3.5	0.3	3.5	0.3	4.5	0.5	5.5	0.7
50°F	3.5	0.3	3.5	0.3	3.5	0.3	3.5	0.3	4.5	0.5	5.5	0.7	6.5	1.0
60°F	3.5	0.3	3.5	0.3	3.5	0.3	4.5	0.5	5.5	0.7	6.5	1.0	7.5	1.3
70°F	3.5	0.3	3.5	0.3	4.5	0.5	5.5	0.7	6.5	1.0	7.5	1.3	8.5	1.7
80°F	3.5	0.3	4.5	0.5	5.5	0.7	6.5	1.0	7.5	1.3	8.5	1.7	12.5	3.4
90°F	4.5	0.5	5.5	0.7	6.5	1.0	7.5	1.3	8.5	1.7	12.5	3.4	14.5	4.4
100°F	5.5	0.7	6.5	1.0	7.5	1.3	8.5	1.7	12.5	3.4	14.5	4.4	16.5	5.6
110°F	6.5	1.0	7.5	1.3	8.5	1.7	12.5	3.4	14.5	4.4	16.5	5.6		

**Note:** All pressure drops are in PSI.

# Flow Rates and Pressure Drop (cont.)

## EW060 Minimum Load Flow

SOURCE EWT	MAX HEATING SET POINT													
	100°F		105°F		110°F		115°F		120°F		125°F		130°F	
	GPM	WPD	GPM	WPD	GPM	WPD	GPM	WPD	GPM	WPD	GPM	WPD	GPM	WPD
30°F	5.5	0.5	5.5	0.5	5.5	0.5	5.5	0.5	5.5	0.5	5.5	0.5	6.0	0.6
40°F	5.5	0.5	5.5	0.5	5.5	0.5	5.5	0.5	5.5	0.5	6.0	0.6	7.5	0.9
50°F	5.5	0.5	5.5	0.5	5.5	0.5	5.5	0.5	6.0	0.6	7.5	0.9	9.0	1.3
60°F	5.5	0.5	5.5	0.5	5.5	0.5	6.0	0.6	7.5	0.9	9.0	1.3	10.5	1.7
70°F	5.5	0.5	5.5	0.5	6.0	0.6	7.5	0.9	9.0	1.3	10.5	1.7	12.0	2.1
80°F	5.5	0.5	6.0	0.6	7.5	0.9	9.0	1.3	10.5	1.7	12.0	2.1	18.0	4.3
90°F	6.0	0.6	7.5	0.9	9.0	1.3	10.5	1.7	12.0	2.1	18.0	4.3	21.0	5.7
100°F	7.5	0.9	9.0	1.3	10.5	1.7	12.0	2.1	18.0	4.3	21.0	5.7		
110°F	9.0	1.3	10.5	1.7	12.0	2.1	18.0	4.3	21.0	5.7				

## Source Flow Rates

MODEL	MINIMUM OPEN LOOP FLOW RATE	MINIMUM CLOSED LOOP FLOW RATE	MAXIMUM FLOW RATE
EW020	3.0	6.0	9.0
EW030	4.0	8.0	12.0
EW042	5.5	11.0	16.5
EW060	7.0	14.0	21.0

## Pressure Drop (PSI @ 90° F EWT)

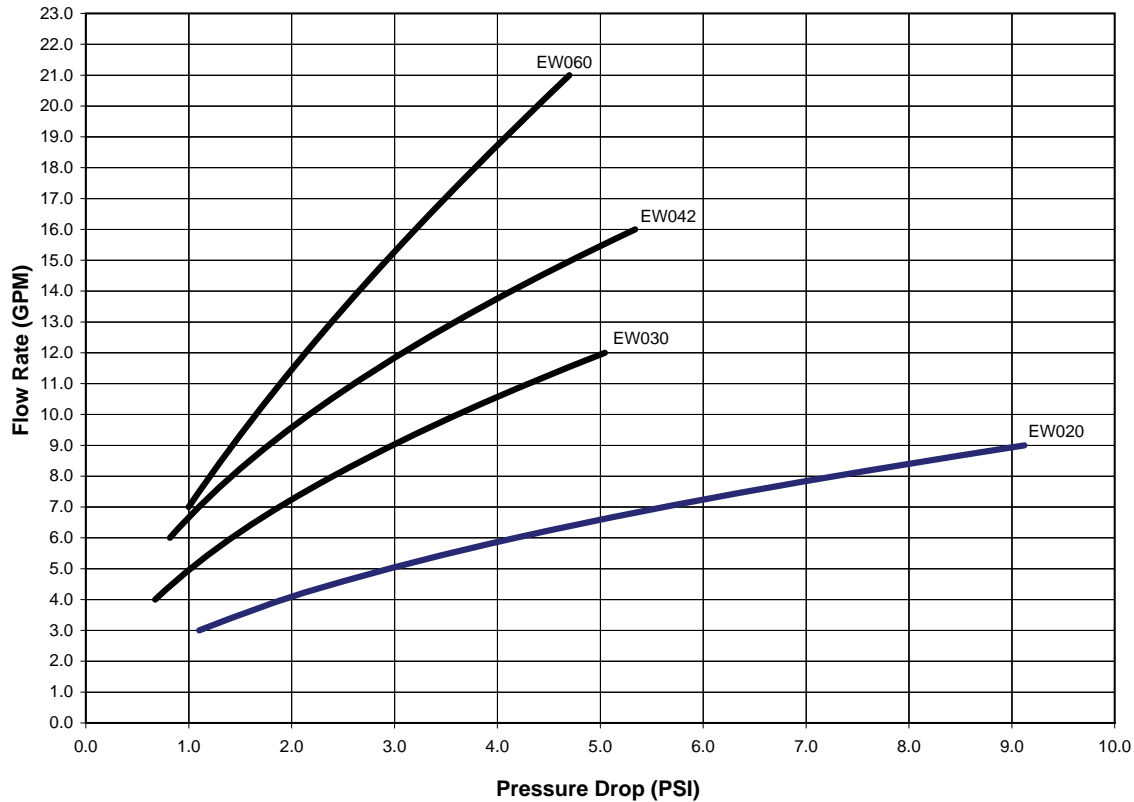

## Reference Calculations

<b>Heating Calculations:</b> $LWT = EWT - \frac{HE}{GPM \times C^*}$ $HE = C^* \times GPM \times (EWT - LWT)$	<b>Cooling Calculations:</b> $LWT = EWT + \frac{HR}{GPM \times C^*}$ $HR = C^* \times GPM \times (LWT - EWT)$
------------------------------------------------------------------------------------------------------------------	------------------------------------------------------------------------------------------------------------------

**Note:** \* C = 500 for pure water, 485 for brine.

## Legends and Notes

Abbreviations and Definitions			
<b>ELT</b>	= entering load fluid temperature to heat pump	<b>kW</b>	= kilowatts
<b>SWPD</b>	= source coax water pressure drop	<b>EST</b>	= entering source fluid temperature to heat pump
<b>LLT</b>	= leaving load fluid temperature from heat pump	<b>HE</b>	= heat extracted in MBTUH
<b>PSI</b>	= pressure drop in pounds per square inch	<b>LST</b>	= leaving source fluid temperature from heat pump
<b>LGPM</b>	= load flow in gallons per minute	<b>HC</b>	= total heating capacity in MBTUH
<b>FT HD</b>	= pressure drop in feet of head	<b>COP</b>	= coefficient of performance, heating [HC/kW x 3.413]
<b>LWPD</b>	= load coax water pressure drop	<b>EER</b>	= energy efficiency ratio, cooling
<b>LWT</b>	= leaving water temperature	<b>TC</b>	= total cooling capacity in MBTUH
<b>EWT</b>	= entering water temperature	<b>HR</b>	= heat rejected in MBTUH
<b>Brine</b>	= water with a freeze inhibiting solution		

# Capacity Data

## EW020 Heating

ELT °F	EST °F	Load Flow			Source Flow - 3 GPM								Source Flow - 6 GPM								Source Flow - 9 GPM							
		Flow GPM	PD		LLT °F	HC kBTUH	Power kW	HE kBTUH	COP	LST °F	Source PD		LLT °F	HC kBTUH	Power kW	HE kBTUH	COP	LST °F	Source PD		LLT °F	HC kBTUH	Power kW	HE kBTUH	COP	LST °F	Source PD	
			PSI	FT HD							PSI	FT HD							PSI	FT HD							PSI	FT HD
60	30	3	1.2	2.8								74	20.3	1.24	16.1	4.81	25	4.9	11.3	74	21.0	1.25	16.7	4.92	26	10.6	24.5	
		6	4.5	10.4								67	21.2	1.25	16.9	4.97	24	4.9	11.3	67	21.9	1.26	17.6	5.09	26	10.6	24.5	
		9	9.7	22.4								65	21.6	1.26	17.3	5.00	24	4.9	11.3	65	22.3	1.28	18.0	5.12	26	10.6	24.5	
	50	3	1.2	2.8	77	24.8	1.24	20.6	5.87	36	1.2	2.6	77	25.1	1.25	20.9	5.89	43	4.6	10.6	77	26.0	1.26	21.7	6.04	45	10.0	23.1
		6	4.5	10.4	69	25.9	1.25	21.7	6.08	36	1.2	2.6	69	26.3	1.26	22.0	6.10	43	4.6	10.6	69	27.2	1.28	22.8	6.24	45	10.0	23.1
		9	9.7	22.4	86	26.4	1.26	22.1	6.11	35	1.2	2.6	66	26.7	1.28	22.4	6.13	43	4.6	10.6	66	27.7	1.29	23.3	6.28	45	10.0	23.1
	70	3	1.2	2.8	80	29.8	1.26	25.5	6.95	53	1.1	2.4	80	30.2	1.27	25.9	6.98	61	4.3	9.9	81	31.3	1.28	26.9	7.14	64	9.4	21.7
		6	4.5	10.4	70	31.2	1.27	26.9	7.19	52	1.1	2.4	71	31.6	1.28	27.2	7.22	61	4.3	9.9	71	32.7	1.30	28.3	7.39	64	9.4	21.7
		9	9.7	22.4	67	31.7	1.29	27.3	7.23	52	1.1	2.4	67	32.2	1.30	27.7	7.26	61	4.3	9.9	67	33.3	1.31	28.8	7.43	64	9.4	21.7
	90	3	1.2	2.8	82	32.9	1.26	28.6	7.63	71	1.1	2.2	82	33.4	1.28	29.0	7.66	80	4.0	9.2	83	34.5	1.29	30.1	7.85	83	8.8	20.3
		6	4.5	10.4	71	34.5	1.28	30.1	7.90	70	1.1	2.2	72	34.9	1.29	30.5	7.93	80	4.0	9.2	72	36.1	1.30	31.7	8.12	83	8.8	20.3
		9	9.7	22.4	68	35.0	1.29	30.6	7.94	70	1.1	2.2	68	35.5	1.31	31.1	7.97	80	4.0	9.2	68	36.7	1.32	32.2	8.17	83	8.8	20.3
110	3	1.2	2.8	86	38.6	1.33	34.1	8.49	87	1.0	2.1	86	39.2	1.35	34.6	8.52	98	3.8	8.8	87	40.5	1.36	35.9	8.73	102	8.2	18.9	
	6	4.5	10.4	73	40.4	1.35	35.8	8.79	86	1.0	2.1	74	41.0	1.36	36.3	8.82	98	3.8	8.8	74	42.4	1.38	37.7	9.03	102	8.2	18.9	
	9	9.7	22.4	69	41.1	1.36	36.4	8.84	86	1.0	2.1	69	41.7	1.38	37.0	8.87	98	3.8	8.8	70	43.1	1.39	38.3	9.08	101	8.2	18.9	
80	30	3	1.1	2.5								94	20.6	1.68	14.9	3.59	25	4.9	11.3	94	21.3	1.70	15.5	3.68	27	10.6	24.5	
		6	4.2	9.7								87	21.6	1.70	15.8	3.72	25	4.9	11.3	87	22.3	1.72	16.4	3.81	26	10.6	24.5	
		9	9.1	21.0								85	21.9	1.72	16.1	3.74	25	4.9	11.3	85	22.7	1.74	16.8	3.83	26	10.6	24.5	
	50	3	1.1	2.5	97	25.2	1.71	19.4	4.32	37	1.2	2.6	97	25.5	1.73	19.7	4.34	43	4.6	10.6	98	26.4	1.74	20.5	4.44	45	10.0	23.1
		6	4.2	9.7	89	26.4	1.73	20.5	4.47	36	1.2	2.6	89	26.7	1.75	20.8	4.49	43	4.6	10.6	89	27.6	1.76	21.6	4.59	45	10.0	23.1
		9	9.1	21.0	86	26.8	1.75	20.8	4.50	36	1.2	2.6	86	27.2	1.76	21.1	4.51	43	4.6	10.6	86	28.1	1.78	22.0	4.62	45	10.0	23.1
	70	3	1.1	2.5	100	30.3	1.76	24.3	5.05	54	1.1	2.4	100	30.7	1.78	24.7	5.07	62	4.3	9.9	101	31.8	1.80	25.7	5.19	64	9.4	21.7
		6	4.2	9.7	91	31.7	1.78	25.6	5.22	53	1.1	2.4	91	32.1	1.80	26.0	5.24	61	4.3	9.9	91	33.3	1.82	27.1	5.37	64	9.4	21.7
		9	9.1	21.0	87	32.2	1.80	26.1	5.25	53	1.1	2.4	87	32.7	1.82	26.5	5.27	61	4.3	9.9	88	33.8	1.84	27.5	5.40	64	9.4	21.7
	90	3	1.1	2.5	102	33.5	1.79	27.4	5.47	72	1.1	2.2	103	33.9	1.81	27.8	5.49	81	4.0	9.2	103	35.1	1.83	28.9	5.62	84	8.8	20.3
		6	4.2	9.7	92	35.0	1.81	28.8	5.66	71	1.1	2.2	92	35.5	1.83	29.2	5.68	80	4.0	9.2	92	36.7	1.85	30.4	5.81	83	8.8	20.3
		9	9.1	21.0	88	35.6	1.83	29.4	5.69	70	1.1	2.2	88	36.1	1.85	29.8	5.71	80	4.0	9.2	88	37.3	1.87	31.0	5.85	83	8.8	20.3
110	3	1.1	2.5	106	39.3	1.85	33.0	6.23	88	1.0	2.1	107	39.8	1.86	33.4	6.26	99	3.8	8.8	107	41.2	1.88	34.7	6.41	102	8.2	18.9	
	6	4.2	9.7	94	41.1	1.87	34.7	6.45	87	1.0	2.1	94	41.6	1.89	35.2	6.47	98	3.8	8.8	94	43.1	1.90	36.6	6.63	102	8.2	18.9	
	9	9.1	21.0	89	41.8	1.89	35.3	6.49	86	1.0	2.1	89	42.3	1.91	35.8	6.51	98	3.8	8.8	90	43.8	1.92	37.2	6.67	102	8.2	18.9	
100	30	3	1.0	2.3								114	20.9	2.12	13.7	2.90	25	4.9	11.3	114	21.7	2.14	14.4	2.97	27	10.6	24.5	
		6	3.9	9.0								107	21.9	2.14	14.6	3.00	25	4.9	11.3	108	22.7	2.16	15.3	3.07	27	10.6	24.5	
		9	8.5	19.6								105	22.3	2.16	14.9	3.02	25	4.9	11.3	105	23.0	2.19	15.6	3.09	27	10.6	24.5	
	50	3	1.0	2.3	117	25.6	2.13	18.3	3.52	38	1.2	2.6	117	26.0	2.15	18.6	3.54	44	4.6	10.6	118	26.8	2.17	19.4	3.62	46	10.0	23.1
		6	3.9	9.0	109	26.8	2.15	19.4	3.65	37	1.2	2.6	109	27.1	2.17	19.7	3.66	43	4.6	10.6	109	28.1	2.20	20.6	3.75	45	10.0	23.1
		9	8.5	19.6	106	27.2	2.18	19.8	3.67	37	1.2	2.6	106	27.6	2.20	20.1	3.68	43	4.6	10.6	106	28.6	2.22	21.0	3.77	45	10.0	23.1
	70	3	1.0	2.3	121	30.8	2.16	23.4	4.19	54	1.1	2.4	121	31.2	2.18	23.8	4.20	62	4.3	9.9	122	32.3	2.20	24.8	4.30	64	9.4	21.7
		6	3.9	9.0	111	32.2	2.18	24.8	4.33	53	1.1	2.4	111	32.7	2.20	25.1	4.35	62	4.3	9.9	111	33.8	2.22	26.2	4.45	64	9.4	21.7
		9	8.5	19.6	107	32.8	2.20	25.2	4.36	53	1.1	2.4	107	33.2	2.23	25.6	4.37	61	4.3	9.9	108	34.4	2.25	26.7	4.48	64	9.4	21.7
	90	3	1.0	2.3	123	34.0	2.19	26.5	4.54	72	1.1	2.2	123	34.5	2.22	26.9	4.56	81	4.0	9.2	124	35.7	2.24	28.0	4.67	84	8.8	20.3
		6	3.9	9.0	112	35.6	2.22	28.0	4.70	71	1.1	2.2	112	36.1	2.24	28.4	4.72	81	4.0	9.2	112	37.3	2.26	29.6	4.83	83	8.8	20.3
		9	8.5	19.6	108	36.2	2.24	28.5	4.73	71	1.1	2.2	108	36.7	2.27	28.9	4.74	80	4.0	9.2	108	37.9	2.29	30.1	4.86	83	8.8	20.3
110	3	1.0	2.3	127	39.9	2.23	32.3	5.25	88	1.0	2.1	127	40.4	2.25	32.8	5.27	99	3.8	8.8	128	41.8	2.27	34.1	5.40	102	8.2	18.9	
	6	3.9	9.0	114	41.7	2.25	34.0	5.44	87	1.0	2.1	114	42.3	2.27	34.5	5.45	98	3.8	8.8	115	43.8	2.30	35.9	5.59	102	8.2	18.9	
	9	8.5	19.6	109	42.4	2.27	34.7	5.47	87	1.0	2.1	110	43.0	2.30	35.2	5.49	98	3.8	8.8	110	44.5	2.32	36.6	5.62	102	8.2	18.9	
120	30	3	1.0	2.3								134	21.3	2.66	12.3	2.35	26	4.9	11.3	135	22.1	2.69	12.9	2.41	27	10.6	24.5	
		6	3.6	8.3								127	22.3	2.69	13.1	2.43	26	4.9	11.3	128	23.1	2.71	13.8	2.49	27	10.6	24.5	
		9	7.9	18.3								125	22.7	2.72	13.4	2.45	26	4.9	11.3	125	23.5	2.74	14.1	2.51	27	10.6	24.5	
	50	3	1.0	2.3																								
		6	3.6	8.3	129	27.3	2.78	17.8	2.88	38	1.2	2.6	129	27.7	2.80	18.1	2.89	44	4.6	10.6	130	28.6	2.83	19.0	2.96	46	10.0	23.1
		9	7.9	18.3	126	27.8	2.81	18.2	2.90	38	1.2	2.6	126	28.1	2.83	18.5	2.91	44	4.6	10.6	126	29.1	2.86	19.3	2.98	46	10.0	23.1
	70	3	1.0	2.3																								
		6	3.6	8.3	131	32.9	2.88	23.1	3.35	55																		

# Capacity Data (cont.)

## EW030H/R Heating - Heating Only or Reversible Unit

ELT °F	EST °F	Load Flow			Source Flow - 4 GPM							Source Flow - 8 GPM							Source Flow - 12 GPM									
		Flow GPM	PD		LLT °F	HC kBTUH	Power kW	HE kBTUH	COP	LST °F	Source PD		LLT °F	HC kBTUH	Power kW	HE kBTUH	COP	LST °F	Source PD		LLT °F	HC kBTUH	Power kW	HE kBTUH	COP	LST °F	Source PD	
			PSI	FT HD							PSI	FT HD							PSI	FT HD							PSI	FT HD
60	30	4	1.1	2.5	74	28.5	1.55	23.2	5.39	23	1.2	2.7	74	28.8	1.56	23.5	5.41	27	3.1	7.1	75	29.8	1.58	24.5	5.54	28	5.5	12.7
		8	2.8	6.6	67	29.8	1.56	24.4	5.58	23	1.2	2.7	68	30.2	1.58	24.8	5.60	26	3.1	7.1	68	31.2	1.60	25.8	5.73	28	5.5	12.7
		12	5.0	11.6	65	30.3	1.58	24.9	5.61	23	1.2	2.7	65	30.7	1.60	25.2	5.63	26	3.1	7.1	65	31.7	1.61	26.2	5.77	28	5.5	12.7
	50	4	1.1	2.5	79	38.3	1.55	32.9	7.21	41	1.1	2.5	79	38.8	1.57	33.4	7.24	45	2.9	6.7	80	40.1	1.59	34.7	7.41	47	5.2	11.9
		8	2.8	6.6	70	40.0	1.57	34.6	7.46	40	1.1	2.5	70	40.6	1.59	35.1	7.49	45	2.9	6.7	70	42.0	1.60	36.5	7.67	47	5.2	11.9
		12	5.0	11.6	67	40.7	1.59	35.3	7.50	40	1.1	2.5	67	41.2	1.61	35.8	7.53	45	2.9	6.7	67	42.7	1.62	37.1	7.71	46	5.2	11.9
	70	4	1.1	2.5	83	45.3	1.62	39.7	8.19	59	1.0	2.4	83	45.9	1.64	40.3	8.22	64	2.7	6.3	84	47.5	1.65	41.8	8.42	66	4.9	11.2
		8	2.8	6.6	72	47.4	1.64	41.8	8.47	58	1.0	2.4	72	48.0	1.66	42.4	8.50	64	2.7	6.3	72	49.7	1.67	43.9	8.71	66	4.9	11.2
		12	5.0	11.6	68	48.2	1.66	42.5	8.52	58	1.0	2.4	68	48.8	1.67	43.1	8.55	64	2.7	6.3	68	50.5	1.69	44.7	8.76	66	4.9	11.2
	90	4	1.1	2.5	83	46.7	1.64	41.1	8.34	78	1.0	2.2	84	47.4	1.66	41.7	8.37	84	2.6	5.9	84	49.0	1.68	43.3	8.57	86	4.5	10.5
		8	2.8	6.6	72	48.9	1.66	43.2	8.63	78	1.0	2.2	72	49.5	1.7	43.8	8.66	84	2.6	5.9	73	51.2	1.69	45.5	8.87	86	4.5	10.5
		12	5.0	11.6	68	49.7	1.68	44.0	8.68	77	1.0	2.2	68	50.4	1.70	44.6	8.71	84	2.6	5.9	69	52.1	1.71	46.3	8.92	86	4.5	10.5
110	4	1.1	2.5	84	48.2	1.66	42.5	8.49	98	0.9	2.1	84	48.8	1.68	43.1	8.52	104	2.4	5.5	85	50.5	1.70	44.7	8.73	106	4.2	9.8	
	8	2.8	6.6	73	50.4	1.68	44.7	8.78	97	0.9	2.1	73	51.1	1.70	45.3	8.81	104	2.4	5.5	73	52.8	1.72	47.0	9.03	106	4.2	9.8	
	12	5.0	11.6	69	51.3	1.70	45.4	8.83	97	0.9	2.1	69	52.0	1.72	46.1	8.87	103	2.4	5.5	69	53.7	1.73	47.8	9.08	105	4.2	9.8	
80	30	4	1.0	2.3	94	27.3	1.87	20.9	4.27	24	1.2	2.7	94	27.6	1.89	21.2	4.29	27	3.1	7.1	94	28.6	1.91	22.1	4.39	28	5.5	12.7
		8	2.7	6.2	87	28.5	1.89	22.1	4.42	24	1.2	2.7	87	28.9	1.91	22.4	4.43	27	3.1	7.1	87	29.9	1.93	23.3	4.54	28	5.5	12.7
		12	4.7	10.9	85	29.0	1.91	22.5	4.44	24	1.2	2.7	85	29.4	1.93	22.8	4.46	27	3.1	7.1	85	30.4	1.95	23.7	4.57	28	5.5	12.7
	50	4	1.0	2.3	98	36.3	2.04	29.4	5.23	42	1.1	2.5	98	36.8	2.06	29.8	5.24	46	2.9	6.7	99	38.1	2.08	31.0	5.37	47	5.2	11.9
		8	2.7	6.2	89	38.0	2.06	31.0	5.41	41	1.1	2.5	90	38.5	2.08	31.4	5.42	46	2.9	6.7	90	39.8	2.10	32.7	5.56	47	5.2	11.9
		12	4.7	10.9	86	38.6	2.08	31.5	5.44	41	1.1	2.5	87	39.2	2.10	32.0	5.46	45	2.9	6.7	87	40.5	2.12	33.3	5.59	47	5.2	11.9
	70	4	1.0	2.3	103	46.3	1.96	39.6	6.93	59	1.0	2.4	103	46.9	1.98	40.2	6.95	64	2.7	6.3	104	48.5	2.00	41.7	7.12	66	4.9	11.2
		8	2.7	6.2	92	48.4	1.98	41.7	7.17	58	1.0	2.4	92	49.1	2.00	42.2	7.19	64	2.7	6.3	93	50.8	2.02	43.9	7.36	66	4.9	11.2
		12	4.7	10.9	88	49.2	2.00	42.4	7.21	58	1.0	2.4	88	49.9	2.02	43.2	7.23	64	2.7	6.3	89	51.6	2.04	44.6	7.41	66	4.9	11.2
	90	4	1.0	2.3	106	51.1	2.12	43.9	7.08	77	1.0	2.2	106	51.8	2.14	44.5	7.11	84	2.6	5.9	107	53.6	2.16	46.2	7.28	86	4.5	10.5
		8	2.7	6.2	93	53.5	2.14	46.2	7.33	77	1.0	2.2	94	54.2	2.16	46.8	7.35	83	2.6	5.9	94	56.1	2.18	48.6	7.53	85	4.5	10.5
		12	4.7	10.9	89	54.4	2.16	47.0	7.37	77	1.0	2.2	89	55.1	2.18	47.7	7.40	83	2.6	5.9	90	57.0	2.21	49.5	7.58	85	4.5	10.5
110	4	1.0	2.3	107	53.3	1.16	49.4	13.49	96	0.9	2.1	107	54.1	1.17	50.1	13.53	103	2.4	5.5	108	55.9	1.18	51.9	13.86	105	4.2	9.8	
	8	2.7	6.2	94	55.8	1.17	51.8	13.95	95	0.9	2.1	94	56.6	1.18	52.5	14.00	102	2.4	5.5	95	58.5	1.20	54.4	14.34	105	4.2	9.8	
	12	4.7	10.9	89	56.7	1.18	52.7	14.03	95	0.9	2.1	90	57.5	1.20	53.4	14.08	102	2.4	5.5	90	59.5	1.21	55.4	14.42	105	4.2	9.8	
100	30	4	0.9	2.2	113	26.4	2.62	17.5	2.95	25	1.2	2.7	113	26.8	2.65	17.7	2.96	27	3.1	7.1	114	27.7	2.68	18.6	3.03	28	5.5	12.7
		8	2.5	5.8	107	27.6	2.65	18.6	3.05	25	1.2	2.7	107	28.0	2.68	18.9	3.06	27	3.1	7.1	107	29.0	2.71	19.7	3.14	28	5.5	12.7
		12	4.4	10.2	105	28.1	2.68	18.9	3.07	25	1.2	2.7	105	28.5	2.71	19.2	3.08	27	3.1	7.1	105	29.5	2.74	20.1	3.15	28	5.5	12.7
	50	4	0.9	2.2	117	34.5	2.63	25.5	3.84	43	1.1	2.5	117	35.0	2.66	25.9	3.85	46	2.9	6.7	118	36.2	2.69	27.0	3.95	47	5.2	11.9
		8	2.5	5.8	109	36.1	2.66	27.0	3.97	42	1.1	2.5	109	36.6	2.69	27.4	3.99	46	2.9	6.7	109	37.9	2.72	28.6	4.08	47	5.2	11.9
		12	4.4	10.2	106	36.7	2.69	27.5	4.00	42	1.1	2.5	106	37.2	2.72	27.9	4.01	46	2.9	6.7	106	38.5	2.75	29.1	4.11	47	5.2	11.9
	70	4	0.9	2.2	119	38.7	2.64	29.7	4.29	62	1.0	2.4	120	39.2	2.67	30.1	4.31	66	2.7	6.3	120	40.5	2.69	31.4	4.41	67	4.9	11.2
		8	2.5	5.8	110	40.4	2.67	31.3	4.44	61	1.0	2.4	110	41.0	2.70	31.8	4.46	65	2.7	6.3	111	42.4	2.72	33.1	4.57	67	4.9	11.2
		12	4.4	10.2	107	41.1	2.70	31.9	4.47	61	1.0	2.4	107	41.7	2.72	32.4	4.49	65	2.7	6.3	107	43.1	2.75	33.7	4.59	67	4.9	11.2
	90	4	0.9	2.2	126	51.6	2.67	42.5	5.66	78	1.0	2.2	126	52.3	2.70	43.1	5.68	84	2.6	5.9	127	54.1	2.73	44.8	5.81	86	4.5	10.5
		8	2.5	5.8	113	54.0	2.70	44.7	5.85	77	1.0	2.2	114	54.7	2.73	45.4	5.87	84	2.6	5.9	114	56.6	2.76	47.2	6.01	86	4.5	10.5
		12	4.4	10.2	109	54.9	2.73	45.6	5.89	77	1.0	2.2	109	55.6	2.76	46.2	5.91	83	2.6	5.9	110	57.5	2.79	48.0	6.05	85	4.5	10.5
110	4	0.9	2.2	127	53.9	2.33	45.9	6.79	97	0.9	2.1	127	54.6	2.35	46.6	6.81	103	2.4	5.5	128	56.5	2.37	48.4	6.98	105	4.2	9.8	
	8	2.5	5.8	114	56.3	2.35	48.3	7.02	96	0.9	2.1	114	57.1	2.38	49.0	7.05	103	2.4	5.5	115	59.1	2.40	50.9	7.22	105	4.2	9.8	
	12	4.4	10.2	110	57.3	2.38	49.2	7.06	96	0.9	2.1	110	58.1	2.40	49.9	7.09	103	2.4	5.5	110	60.1	2.43	51					



# Capacity Data (cont.)

## EW042H/R Heating - Heating Only or Reversible Unit

ELT °F	EST °F	Load Flow			Source Flow - 5.5 GPM							Source Flow - 11 GPM							Source Flow - 16.5 GPM										
		Flow GPM	PD		LLT °F	HC kBTUH	Power kW	HE kBTUH	COP	LST °F	Source PD		LLT °F	HC kBTUH	Power kW	HE kBTUH	COP	LST °F	Source PD		LLT °F	HC kBTUH	Power kW	HE kBTUH	COP	LST °F	Source PD		
			PSI	FT HD							PSI	FT HD							PSI	FT HD							PSI	FT HD	PSI
60	30	5.5	0.7	2.5	75	40.7	2.29	32.9	5.20	21	0.8	2.7	75	41.2	2.31	33.3	5.22	25	3.1	7.2	76	42.7	2.34	34.7	5.35	27	5.5	12.7	
		11	2.8	6.6	68	42.6	2.32	34.7	5.38	20	0.8	2.7	68	43.1	2.34	35.2	5.40	25	3.1	7.2	68	44.6	2.36	36.6	5.53	27	5.5	12.7	
		16.5	6.0	11.6	65	43.3	2.34	35.3	5.42	20	0.8	2.7	65	43.9	2.37	35.8	5.44	25	3.1	7.2	66	45.4	2.39	37.2	5.57	26	5.5	12.7	
	50	5.5	1.1	2.5	81	56.5	2.43	48.2	6.80	36	0.8	2.6	81	57.2	2.46	48.8	6.82	43	2.9	6.8	82	59.2	2.48	50.7	6.99	45	5.2	12.0	
		11	2.8	6.6	71	59.1	2.46	50.7	7.03	36	0.8	2.6	71	59.9	2.5	51.4	7.06	43	2.9	6.8	71	61.9	2.51	53.4	7.23	45	5.2	12.0	
		16.5	5.0	11.6	67	60.1	2.49	51.6	7.07	35	0.8	2.6	67	60.9	2.51	52.3	7.10	43	2.9	6.8	68	63.0	2.54	54.3	7.27	45	5.2	12.0	
	70	5.5	1.1	2.5	86	72.2	2.58	63.5	8.21	52	0.7	2.4	87	73.2	2.60	64.4	8.24	61	2.7	6.4	88	75.8	2.63	66.8	8.44	64	4.9	11.3	
		11	2.8	6.6	74	75.6	2.61	66.7	8.50	51	0.7	2.4	74	76.6	2.63	67.6	8.53	60	2.7	6.4	74	79.2	2.66	70.2	8.73	63	4.9	11.3	
		16.5	5.0	11.6	69	76.8	2.64	67.9	8.55	51	0.7	2.4	69	77.9	2.66	68.8	8.58	60	2.7	6.4	70	80.6	2.69	71.4	8.78	63	4.9	11.3	
	90	5.5	1.1	2.5	89	78.5	2.63	69.6	8.77	70	1.0	2.2	89	79.6	2.65	70.5	8.80	80	2.6	6.0	90	82.3	2.68	73.2	9.01	83	4.5	10.5	
		11	2.8	6.6	75	82.1	2.65	73.1	9.07	69	1.0	2.2	75	83.3	2.7	74.1	9.10	79	2.6	6.0	76	86.1	2.71	76.9	9.32	83	4.5	10.5	
		16.5	5.0	11.6	70	83.5	2.68	74.4	9.12	69	1.0	2.2	70	84.7	2.71	75.4	9.15	79	2.6	6.0	71	87.6	2.74	78.2	9.38	83	4.5	10.5	
	110	5.5	1.1	2.5	91	84.8	2.67	75.7	9.30	88	0.9	2.1	91	86.0	2.70	76.7	9.33	99	2.4	5.5	92	88.9	2.73	79.6	9.56	102	4.2	9.8	
		11	2.8	6.6	76	88.7	2.70	79.5	9.62	87	0.9	2.1	76	89.9	2.73	80.6	9.66	98	2.4	5.5	77	93.0	2.76	83.6	9.89	102	4.2	9.8	
		16.5	5.0	11.6	71	90.2	2.73	80.9	9.68	87	0.9	2.1	71	91.4	2.76	82.0	9.71	98	2.4	5.5	71	96.0	2.79	85.1	9.95	102	4.2	9.8	
	80	30	5.5	1.0	2.3	95	42.2	3.21	31.2	3.85	21	1.2	2.7	96	42.7	3.24	31.7	3.87	25	3.1	7.2	96	44.2	3.27	33.0	3.96	27	5.5	12.7
			11	2.7	6.2	88	44.1	3.24	33.0	3.98	21	1.2	2.7	88	44.7	3.3	33.5	4.00	25	3.1	7.2	88	46.2	3.31	34.9	4.09	27	5.5	12.7
			16.5	4.7	10.9	85	44.8	3.28	33.6	4.01	20	1.2	2.7	86	45.4	3.31	34.1	4.02	25	3.1	7.2	86	47.0	3.34	35.6	4.12	27	5.5	12.7
50		5.5	1.0	2.3	100	55.8	3.23	44.7	5.06	37	1.1	2.6	101	56.5	3.27	45.4	5.07	44	2.9	6.8	101	58.5	3.30	47.2	5.20	46	5.2	12.0	
		11	2.7	6.2	91	58.3	3.27	47.2	5.23	37	1.1	2.6	91	59.1	3.3	47.9	5.25	43	2.9	6.8	91	61.2	3.34	49.8	5.38	45	5.2	12.0	
		16.5	4.7	10.9	87	59.3	3.31	48.1	5.26	36	1.1	2.6	87	60.1	3.34	48.8	5.28	43	2.9	6.8	88	62.2	3.37	50.7	5.41	45	5.2	12.0	
70		5.5	1.0	2.3	105	69.4	3.26	58.3	6.24	53	1.0	2.4	106	70.4	3.29	59.1	6.26	62	2.7	6.4	106	72.8	3.33	61.4	6.41	64	4.9	11.3	
		11	2.7	6.2	93	72.6	3.30	61.4	6.46	52	1.0	2.4	93	73.6	3.33	62.2	6.48	61	2.7	6.4	94	76.1	3.36	64.7	6.64	64	4.9	11.3	
		16.5	4.7	10.9	89	73.8	3.33	62.5	6.49	52	1.0	2.4	89	74.8	3.37	63.4	6.52	61	2.7	6.4	89	77.4	3.40	65.8	6.67	64	4.9	11.3	
90		5.5	1.0	2.3	109	80.8	3.33	69.5	7.12	70	1.0	2.2	110	82.0	3.36	70.5	7.15	80	2.6	6.0	111	84.8	3.39	73.2	7.32	83	4.5	10.5	
		11	2.7	6.2	95	84.6	3.36	73.1	7.37	69	1.0	2.2	96	85.7	3.4	74.1	7.39	79	2.6	6.0	96	88.7	3.43	77.0	7.57	83	4.5	10.5	
		16.5	4.7	10.9	90	86.0	3.40	74.4	7.41	69	1.0	2.2	91	87.2	3.44	75.4	7.44	79	2.6	6.0	91	90.2	3.47	78.3	7.62	83	4.5	10.5	
110		5.5	1.0	2.3	114	92.3	3.40	80.7	7.96	87	0.9	2.1	114	93.5	3.43	81.8	7.99	98	2.4	5.5	115	96.8	3.46	84.9	8.19	102	4.2	9.8	
		11	2.7	6.2	98	96.5	3.43	84.8	8.24	86	0.9	2.1	98	97.8	3.47	86.0	8.27	98	2.4	5.5	98	101.2	3.50	89.3	8.47	101	4.2	9.8	
		16.5	4.7	10.9	92	98.1	3.47	86.3	8.29	85	0.9	2.1	92	99.5	3.51	87.5	8.32	97	2.4	5.5	92	102.9	3.54	90.8	8.52	101	4.2	9.8	
100		30	5.5	0.9	2.2	115	41.2	4.08	27.3	2.96	22	1.2	2.7	115	41.8	4.12	27.7	2.97	26	3.1	7.2	116	43.2	4.16	29.0	3.04	27	5.5	12.7
			11	2.5	5.8	108	43.1	4.12	29.0	3.06	22	1.2	2.7	108	43.7	4.17	29.5	3.07	26	3.1	7.2	108	45.2	4.21	30.8	3.15	27	5.5	12.7
			16.5	4.4	10.2	105	43.8	4.17	29.6	3.08	22	1.2	2.7	105	44.4	4.21	30.0	3.09	26	3.1	7.2	106	45.9	4.25	31.4	3.17	27	5.5	12.7
	50	5.5	0.9	2.2	120	53.9	4.11	39.9	3.85	39	1.1	2.6	120	54.6	4.15	40.5	3.86	44	2.9	6.8	121	56.5	4.19	42.2	3.95	46	5.2	12.0	
		11	2.5	5.8	110	56.4	4.15	42.2	3.98	38	1.1	2.6	110	57.1	4.2	42.8	3.99	44	2.9	6.8	111	59.1	4.23	44.6	4.09	46	5.2	12.0	
		16.5	4.4	10.2	107	57.3	4.20	43.0	4.00	38	1.1	2.6	107	58.1	4.24	43.6	4.02	44	2.9	6.8	107	60.1	4.28	45.5	4.11	46	5.2	12.0	
	70	5.5	0.9	2.2	124	66.6	4.13	52.5	4.72	55	1.0	2.4	125	67.5	4.17	53.2	4.74	62	2.7	6.4	125	69.8	4.22	55.4	4.85	65	4.9	11.3	
		11	2.5	5.8	113	69.6	4.18	55.4	4.88	54	1.0	2.4	113	70.6	4.22	56.2	4.90	62	2.7	6.4	113	73.0	4.26	58.5	5.02	64	4.9	11.3	
		16.5	4.4	10.2	109	70.8	4.22	56.4	4.91	54	1.0	2.4	109	71.8	4.27	57.2	4.93	62	2.7	6.4	109	74.2	4.31	59.5	5.05	64	4.9	11.3	
	90	5.5	0.9	2.2	129	78.5	4.20	64.1	5.48	72	1.0	2.2	129	79.5	4.24	65.1	5.50	81	2.6	6.0	130	82.3	4.28	67.7	5.63	84	4.5	10.5	
		11	2.5	5.8	115	82.1	4.24	67.6	5.67	71	1.0	2.2	115	83.2	4.3	68.6	5.69	80	2.6	6.0	116	86.0	4.33	71.3	5.83	83	4.5	10.5	
		16.5	4.4	10.2	110	83.4	4.29	68.8	5.70	70	1.0	2.2	110	84.6	4.33	69.8	5.72	80	2.6	6.0	111	87.5	4.38	72.6	5.86	83	4.5	10.5	
	110	5.5	0.9	2.2	133	90.3	4.26	75.8	6.21	88	0.9	2.1	133	91.6	4.30	76.9	6.24	99	2.4	5.5	134	94.7	4.35	79.9	6.39	102	4.2	9.8	
		11	2.5	5.8	117	94.5	4.31	79.8	6.43	87	0.9	2.1	117	95.8	4.35	80.9	6.45	98	2.4	5.5	118	99.1	4.39	84.1	6.61	102	4.2	9.8	
		16.5	4.4	10.2	112	96.1	4.35	81.2	6.47	87	0.9	2.1	112	97.4	4.40	82.4	6.49	98	2.4	5.5	112	100.8	4.44	85.6	6.65	102	4.2	9.8	
	120	30	5.5	0.9	2.0	134	39.8	5.17	22.2	2.26	24	1.2	2.7	135	40.4	5.23	22.5	2.26	27	3.1	7.2	135	41.7	5.28	23.7	2.32	28	5.5	12.7
			11	2.3	5.4	128	41.6	5.23	23.8	2.33	23	1.2	2.7	128	42.2	5.28	24.2	2.34	27	3.1	7.2	128	43.7	5.34	25.5	2.40	28	5.5	12.7
			16.5	4.1	9.5	125	42.3	5.29	24.3	2.35	23	1.2	2.7	125	42.9	5.34	24.7	2.36	26	3.1	7.2	125	44.4	5.40	26.0	2.41	28	5.5	12.7
50		5.5	0.9	2.0																									
		11	2.3	5.4	130	53.2	5.25	35.3	2.97	40	1.1	2.6	130	53.9	5.3	35.9	2.98	45	2.9	6.8	130	55.8	5.35	37.5</					



# Capacity Data (cont.)

## EW060H/R Heating - Heating Only or Reversible Unit\*

ELT °F	EST °F	Load Flow			Source Flow - 7 GPM						Source Flow - 14 GPM						Source Flow - 21 GPM											
		PD		LLT °F	HC kBTUH	Power kW	HE kBTUH	COP	LST °F	Source PD		LLT °F	HC kBTUH	Power kW	HE kBTUH	COP	LST °F	Source PD		LLT °F	HC kBTUH	Power kW	HE kBTUH	COP	LST °F	Source PD		
		PSI	FT HD							PSI	FT HD							PSI	FT HD							PSI	FT HD	PSI
60	30	7	1.1	2.5	77	59.3	3.43	47.6	5.07	16	1.2	2.7	77	60.1	3.47	48.3	5.08	23	3.1	7.2	78	62.2	3.50	50.3	5.21	25	5.5	12.7
		14	2.8	6.6	69	62.1	3.47	50.2	5.24	16	1.2	2.7	69	62.9	3.51	50.9	5.26	23	3.1	7.2	69	65.1	3.54	53.0	5.39	25	5.5	12.7
		21	5.0	11.6	66	63.1	3.51	51.1	5.27	15	1.2	2.7	66	64.0	3.54	51.9	5.29	23	3.1	7.2	66	66.2	3.58	54.0	5.42	25	5.5	12.7
	50	7	1.1	2.5	82	76.0	3.49	64.1	6.38	32	1.1	2.6	82	77.1	3.53	65.0	6.40	41	2.9	6.8	83	79.7	3.56	67.6	6.56	44	5.2	12.0
		14	2.8	6.6	71	79.5	3.53	67.5	6.60	31	1.1	2.6	72	80.6	3.6	68.5	6.62	40	2.9	6.8	72	83.4	3.60	71.1	6.78	43	5.2	12.0
		21	5.0	11.6	68	80.9	3.57	68.7	6.64	30	1.1	2.6	68	82.0	3.61	69.7	6.66	40	2.9	6.8	68	84.8	3.64	72.4	6.82	43	5.2	12.0
	70	7	1.1	2.5	87	92.8	3.55	80.6	7.65	47	1.0	2.4	87	94.0	3.59	81.8	7.68	58	2.7	6.4	88	97.3	3.63	84.9	7.86	62	4.9	11.3
		14	2.8	6.6	74	97.0	3.59	84.8	7.91	46	1.0	2.4	74	98.3	3.63	86.0	7.94	58	2.7	6.4	75	101.7	3.67	89.2	8.13	62	4.9	11.3
		21	5.0	11.6	69	98.7	3.63	86.3	7.96	45	1.0	2.4	70	100.0	3.67	87.5	7.99	58	2.7	6.4	70	103.4	3.71	90.8	8.18	61	4.9	11.3
	90	7	1.1	2.5	88	98.6	3.60	86.4	8.03	65	1.0	2.2	89	100.0	3.64	87.6	8.06	77	2.6	6.0	90	103.4	3.67	90.9	8.25	81	4.5	10.5
		14	2.8	6.6	75	103.2	3.64	90.8	8.30	64	1.0	2.2	75	104.6	3.7	92.0	8.33	77	2.6	6.0	75	108.2	3.71	95.5	8.54	81	4.5	10.5
		21	5.0	11.6	70	104.9	3.68	92.4	8.35	64	1.0	2.2	70	106.4	3.72	93.7	8.38	77	2.6	6.0	70	110.0	3.76	97.2	8.59	81	4.5	10.5
	110	7	1.1	2.5	90	104.5	3.65	92.1	8.40	84	0.9	2.1	90	106.0	3.69	93.4	8.43	97	2.4	5.5	91	109.6	3.72	96.9	8.63	101	4.2	9.8
		14	2.8	6.6	76	109.3	3.69	96.7	8.68	82	0.9	2.1	76	110.8	3.73	98.1	8.72	96	2.4	5.5	76	114.6	3.76	101.8	8.93	100	4.2	9.8
		21	5.0	11.6	71	111.2	3.73	98.5	8.74	82	0.9	2.1	71	112.7	3.77	99.9	8.77	96	2.4	5.5	71	116.6	3.81	103.6	8.98	100	4.2	9.8
80	30	7	1.0	2.3	96	57.1	4.35	42.3	3.85	18	1.2	2.7	97	57.9	4.40	42.9	3.86	24	3.1	7.2	97	59.9	4.44	44.7	3.95	26	5.5	12.7
		14	2.7	6.2	89	59.8	4.40	44.7	3.98	17	1.2	2.7	89	60.6	4.45	45.4	3.99	24	3.1	7.2	89	62.7	4.49	47.3	4.09	25	5.5	12.7
		21	4.7	10.9	86	60.8	4.45	45.6	4.00	17	1.2	2.7	86	61.6	4.50	46.3	4.02	23	3.1	7.2	86	63.7	4.54	48.2	4.11	25	5.5	12.7
	50	7	1.0	2.3	101	74.1	4.42	59.0	4.91	33	1.1	2.6	101	75.1	4.47	59.9	4.93	41	2.9	6.8	102	77.7	4.51	62.3	5.05	44	5.2	12.0
		14	2.7	6.2	91	77.5	4.47	62.3	5.08	32	1.1	2.6	91	78.6	4.5	63.2	5.10	41	2.9	6.8	92	81.3	4.56	65.7	5.22	44	5.2	12.0
		21	4.7	10.9	88	78.8	4.52	63.4	5.11	32	1.1	2.6	88	79.9	4.57	64.3	5.13	41	2.9	6.8	88	82.7	4.61	66.9	5.25	44	5.2	12.0
	70	7	1.0	2.3	106	91.1	4.49	75.8	5.94	48	1.0	2.4	106	92.4	4.54	76.9	5.97	59	2.7	6.4	107	95.6	4.58	79.9	6.11	62	4.9	11.3
		14	2.7	6.2	94	95.3	4.54	79.8	6.15	47	1.0	2.4	94	96.6	4.59	81.0	6.17	58	2.7	6.4	94	100.0	4.63	84.1	6.32	62	4.9	11.3
		21	4.7	10.9	89	96.9	4.59	81.3	6.19	47	1.0	2.4	89	98.3	4.64	82.4	6.21	58	2.7	6.4	90	101.6	4.69	85.7	6.36	62	4.9	11.3
	90	7	1.0	2.3	109	102.3	4.57	86.7	6.56	65	1.0	2.2	110	103.7	4.62	87.9	6.58	77	2.6	6.0	111	107.2	4.66	91.3	6.74	81	4.5	10.5
		14	2.7	6.2	95	107.0	4.62	91.2	6.79	64	1.0	2.2	95	108.4	4.7	92.5	6.81	77	2.6	6.0	96	112.2	4.71	96.1	6.97	81	4.5	10.5
		21	4.7	10.9	90	108.8	4.67	92.8	6.83	63	1.0	2.2	91	110.3	4.72	94.2	6.85	77	2.6	6.0	91	114.1	4.77	97.8	7.07	81	4.5	10.5
	110	7	1.0	2.3	112	113.4	4.65	97.6	7.15	82	0.9	2.1	113	115.0	4.69	99.0	7.18	96	2.4	5.5	114	118.9	4.74	102.8	7.35	100	4.2	9.8
		14	2.7	6.2	97	118.6	4.70	102.6	7.40	81	0.9	2.1	97	120.3	4.75	104.1	7.43	95	2.4	5.5	98	124.4	4.79	108.0	7.61	100	4.2	9.8
		21	4.7	10.9	91	120.6	4.75	104.4	7.44	80	0.9	2.1	92	122.3	4.80	105.9	7.47	95	2.4	5.5	92	126.5	4.85	110.0	7.65	100	4.2	9.8
100	30	7	0.9	2.2	116	55.0	5.57	36.0	2.89	20	1.2	2.7	116	55.7	5.62	36.5	2.90	25	3.1	7.2	116	57.6	5.68	38.2	2.97	26	5.5	12.7
		14	2.5	5.8	108	57.5	5.63	38.3	2.99	19	1.2	2.7	108	58.3	5.69	38.9	3.00	24	3.1	7.2	109	60.3	5.74	40.7	3.08	26	5.5	12.7
		21	4.4	10.2	106	58.5	5.69	39.0	3.01	19	1.2	2.7	106	59.3	5.75	39.6	3.02	24	3.1	7.2	106	61.3	5.80	41.5	3.09	26	5.5	12.7
	50	7	0.9	2.2	120	71.2	5.44	52.7	3.84	35	1.1	2.6	121	72.2	5.49	53.5	3.85	42	2.9	6.8	121	74.7	5.55	55.8	3.95	45	5.2	12.0
		14	2.5	5.8	111	74.5	5.50	55.7	3.97	34	1.1	2.6	111	75.5	5.6	56.6	3.99	42	2.9	6.8	111	78.1	5.61	59.0	4.08	44	5.2	12.0
		21	4.4	10.2	107	75.8	5.56	56.8	4.00	34	1.1	2.6	107	76.8	5.61	57.6	4.01	42	2.9	6.8	108	79.4	5.67	60.1	4.11	44	5.2	12.0
	70	7	0.9	2.2	125	87.5	5.31	69.4	4.83	50	1.0	2.4	125	88.7	5.36	70.4	4.85	60	2.7	6.4	126	91.7	5.41	73.3	4.97	63	4.9	11.3
		14	2.5	5.8	113	91.5	5.37	73.2	5.00	49	1.0	2.4	113	92.8	5.42	74.3	5.02	59	2.7	6.4	114	96.0	5.47	77.3	5.14	63	4.9	11.3
		21	4.4	10.2	109	93.1	5.42	74.6	5.03	49	1.0	2.4	109	94.3	5.48	75.6	5.05	59	2.7	6.4	109	97.6	5.53	78.7	5.17	63	4.9	11.3
	90	7	0.9	2.2	129	100.6	5.60	81.5	5.27	67	1.0	2.2	129	101.9	5.65	82.7	5.29	78	2.6	6.0	130	105.5	5.71	86.0	5.41	82	4.5	10.5
		14	2.5	5.8	115	105.2	5.66	85.9	5.45	65	1.0	2.2	115	106.6	5.7	87.1	5.47	78	2.6	6.0	116	110.3	5.77	90.6	5.60	81	4.5	10.5
		21	4.4	10.2	110	107.0	5.72	87.5	5.48	65	1.0	2.2	110	108.4	5.78	88.7	5.50	77	2.6	6.0	111	112.2	5.83	92.3	5.63	81	4.5	10.5
	110	7	0.9	2.2	132	113.6	5.88	93.6	5.66	83	0.9	2.1	133	115.2	5.94	94.9	5.68	96	2.4	5.5	134	119.2	6.00	98.7	5.82	101	4.2	9.8
		14	2.5	5.8	117	118.9	5.95	98.6	5.86	82	0.9	2.1	117	120.5	6.01	100.0	5.88	96	2.4	5.5	118	124.6	6.07	103.9	6.02	100	4.2	9.8
		21	4.4	10.2	112	120.9	6.01	100.4	5.89	81	0.9	2.1	112</															



## Accessories and Other Options

### Water Connection Kits (Field Installed)

Water connection kits have been designed to facilitate load-side and loop-side water connections. See IM1470 for more information.

### Earth Loop Pump Kit (Field Installed)

A specially designed one or two-pump module provides all liquid flow, fill and connection requirements for independent single unit systems (230/1/60 only). The one-pump module is capable of 25 feet of head at 16.0 GPM, while the two-pump module is capable of 50 feet of head at 16.0 GPM.

### Desuperheater (Factory Installed, EW042 and EW060 Only)

An optional heat reclaiming desuperheater coil constructed of vented double-wall copper construction suitable for potable water is available. The coil is factory mounted inside the unit. A DPK5 pump kit is required (field installed), which includes a DHW tank connection and a temperature limit pump shutoff.

# Accessories and Other Options (cont.)

## Load-side Pump Kit (Field Installed)

Load pump kits are available to provide all liquid flow requirements for independent single unit systems (230/1/60 only). For the EW020 a Grundfos UP15-42B7 (part number 24P501A04) is recommended for applications which require low flow. To select the proper pump, be certain that the system pressure drop is calculated correctly.

For higher flow applications, a Grundfos UP26-116 (part number EWPK1) is available. Refer to the Pump Curves in Figures 3 and 4 to ensure that the application fits under the pump. If the job requirements are outside the pump curve, an alternate pump will need to be obtained to maintain the necessary flow.

**Figure 3: EWPK1 - Pump Curve**

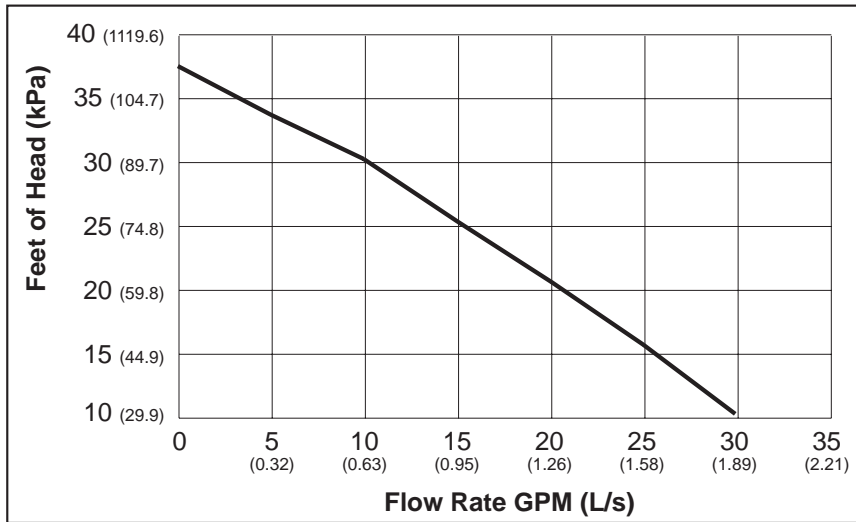

**Figure 4: 24P501A04 - Pump Curve**

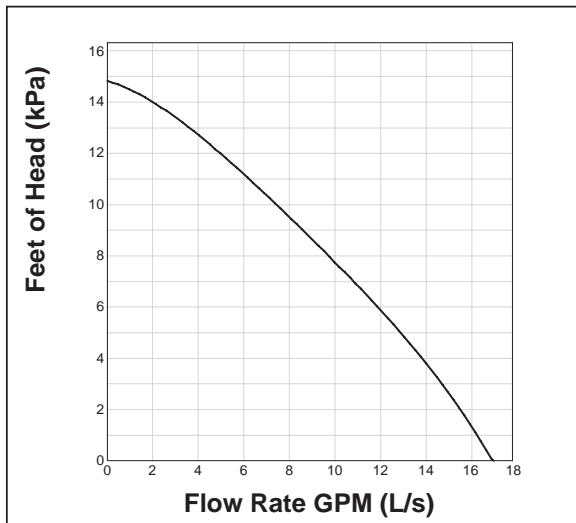

# Engineering Guide Specifications

## General

The liquid source hydronic heat pump is a single packaged heating only or reverse cycle heating/cooling unit. (The EW020 is not available as a reverse cycle unit.) Dedicated non-reversible heating only units shall be easily field convertible to cooling only units. The unit shall be listed by a recognized safety-testing laboratory or agency, such as ETL Testing Laboratory. Each unit shall be computer run-tested at the factory. Each unit shall be pallet mounted and stretch-wrapped for shipping. The hydronic heat pump shall be designed to operate with a source liquid temperature between 30°F and 100°F [-1°C and 38°C].

## Casing and Cabinet

The front access panel of each unit is made of high density non-metallic material. (The top of the EW020 is made of this same material.) The cabinet shall be fabricated from heavy-gauge steel and finished with a corrosion-resistant polyester coating. All units shall have 7/8-inch and 1-1/8-inch knockouts for entrance of low and line voltage wiring.

## Refrigerant Circuit

All units contain a sealed refrigerant circuit including a hermetic motor-compressor, bi-directional thermal expansion valve assembly, reversing valve (except EW020), two coaxial tube water-to-refrigerant heat exchangers, factory-installed high and low-pressure safety switches and service ports as well as a liquid line filter dryer.

Compressors are high-efficiency compliant scroll designed for heat pump duty and mounted on rubber vibration isolators. Compressor motors are single-phase PSC or three-phase, both with overload protection. The coaxial water-to-refrigerant heat exchangers are designed for low water pressure drop and constructed of a cupronickel inner tube and a steel outer tube. The EW020 is constructed of a copper inner tube and vented steel outer tube suitable for potable water systems.

The thermal expansion valve assembly provides proper superheat over the liquid temperature range with minimal "hunting". The valve shall operate bi-directionally without the use of check valves. The water-to-refrigerant heat exchangers, optional desuperheater coil and refrigerant suction lines shall be insulated to prevent condensation at low liquid temperatures.

## Piping

All supply and return water connections (and optional desuperheater connections) are FPT flush-mounted copper threaded fittings (except EW020) mechanically fastened to the unit cabinet, eliminating the need for backup wrenches when making field piping connections. All water piping is insulated to prevent condensation at low liquid temperatures.

## Electrical

Controls and safety devices shall be factory wired and mounted within the unit. Controls shall include compressor contactor, high and low pressure switches, 75VA transformer with built-in circuit breaker, reversing valve coil, compressor control module with integral lockout mode and anti short-cycle protection. A terminal block with screw terminals for field control wiring shall be provided; including load and source pump connections, copper threaded fittings (except EW020) mechanically fastened to the unit cabinet, eliminating the need for backup wrenches when making field piping connections. All water piping is insulated to prevent condensation at low liquid temperatures.

## Controller

The controller is an integrated circuit that controls the load loop pump, source loop pump and compressor by sampling the entering load side water temperature. The LED window displays the current entering load side water temperature. Pressing the mode key will step the controller through each mode. Pressing the up or down arrow once will display the set point. Any additional key presses shall directly change the set point by 1°.

The controller also monitors all fault conditions; high pressure, low pressure and freeze protection. When a fault occurs, the compressor activity shall be suspended and the controller shall enter "Fault Retry" mode. The unit will remain in "Fault Retry" mode for three-five minutes. If a fault occurs three times within one compressor call, the controller will activate "Lock Out" mode. When the controller is in "Lock Out" mode, the fault code will display in the LED window. The controller can also be configured for staging applications when the unit is heating only.



**WaterFurnace**

*Smarter from the Ground Up™*

WaterFurnace International, Inc.  
9000 Conservation Way  
Fort Wayne, IN 46809  
www.waterfurnace.com

Product: **EW Series**  
Type: Hydronic Heat Pumps  
Size: 2 thru 5 Ton

WFI has a policy of continuous product research and development and reserves the right to change design and specifications without notice.  
©2006 WFI.

Document Type: Specification Catalog  
Part Number: SP1469  
Release Date: 02/07  
Supercedes: SP1469 (11/06)