



ENVISION™
NSW Commercial 1.5 to 6 Tons
Geothermal Hydronic Heat Pump



Table of Contents

Model Nomenclature	4
The Envision Series	5-6
Inside the Envision Series.	7
Water Quality	8
Standard Board - Control Features.	9-10
External Control.	10
Standard Control - Panel Configuration.	11-12
Optional Controls	13-17
Envision Application Notes	18-24
Dimensional Data.	25
Electrical Data	26
Physical Data	26
Antifreeze Correction	27
AHRI/ISO 13256-2 Performance Ratings	28
Pressure Drop.	28
Reference Calculations.	29
Legend and Notes	29
Performance Data	30-43
Wiring Schematics.	44-49
Accessories and Options	50-51
Engineering Guide Specifications.	52-53
Revision Guide	55

Model Nomenclature

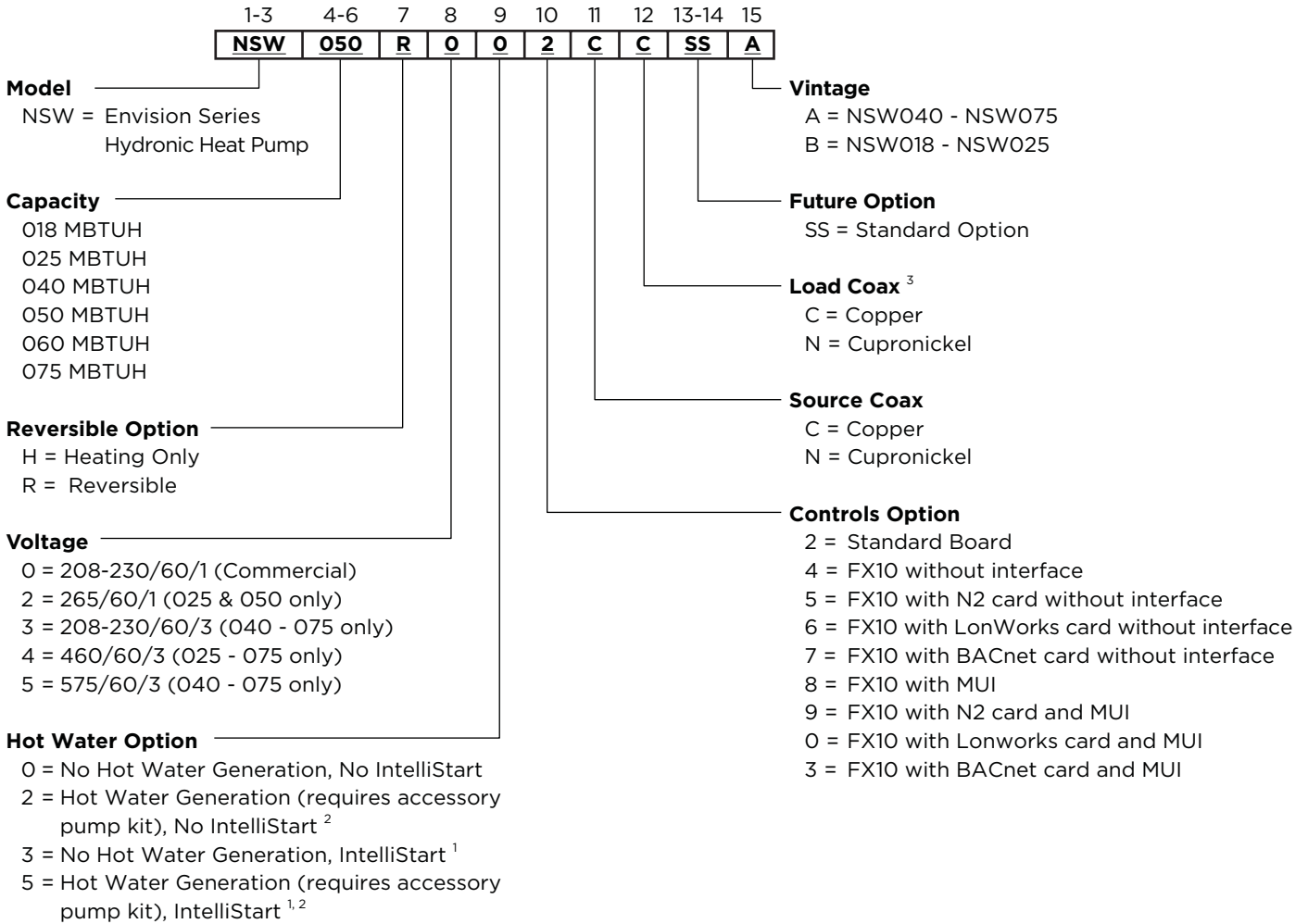

NOTES: ¹ IntelliStart is only available on 208-230/60/1 voltage
² Available on 040, 050, 060, and 075 only. HWG requires field installed external pump kit.
³ NSW018 and NSW025 **heating only** models are available only with copper double wall vented load coax for potable water.



All Envision Series product is safety listed under UL1995 thru ETL and performance listed with AHRI in accordance with standard 13256-2. The Envision Series is also Energy Star rated.

The Envision Series

NSW Features

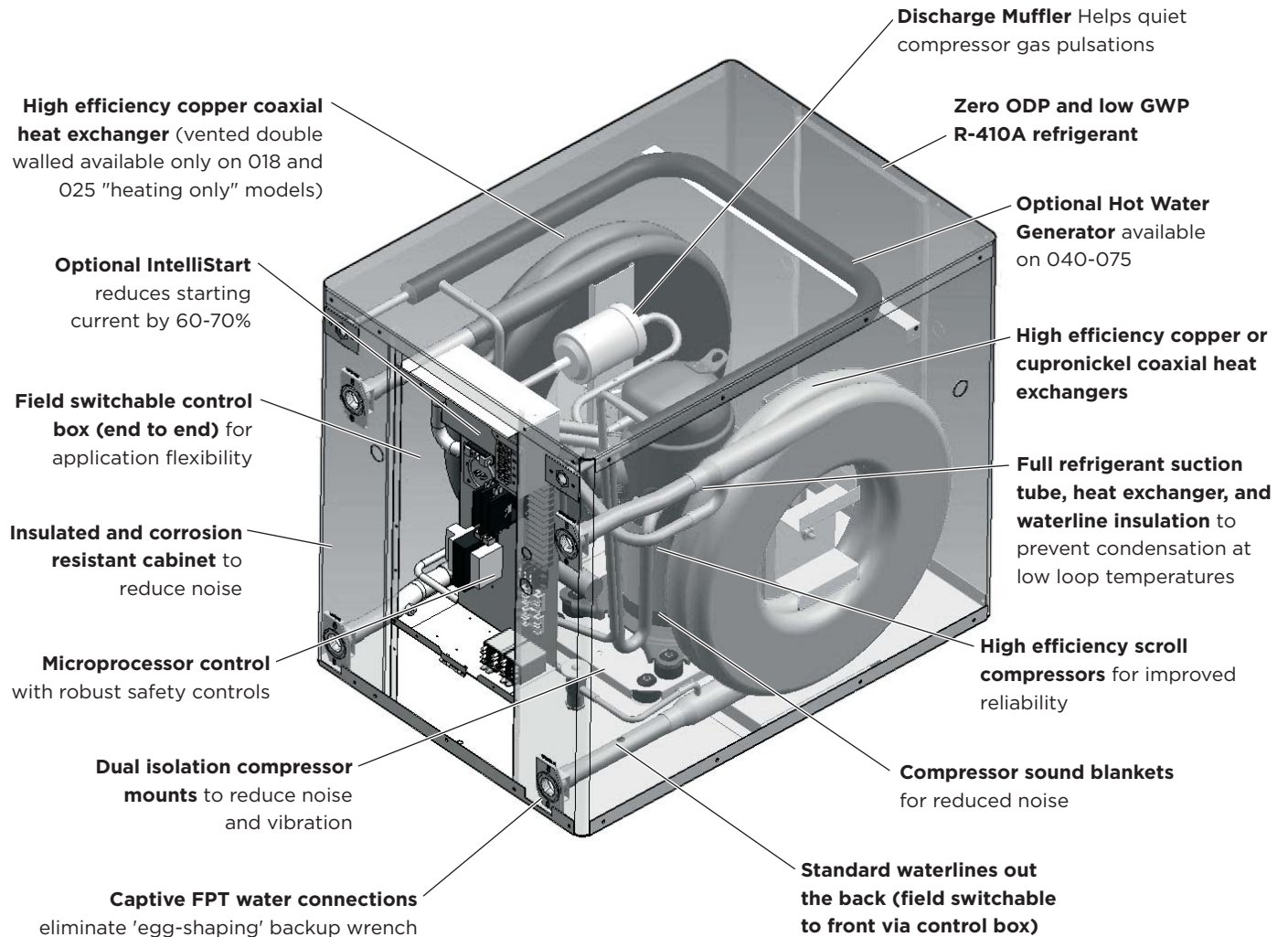

The Envision Series cont.

High Efficiency

The Envision Series are the highest efficiency units available. Large oversized water-to-refrigerant heat exchangers and scroll compressors provide extremely efficient operation. This efficiency means the Envision Series requires less loop than any product on the market. This can mean significant savings on commercial and residential projects.

Operating Efficiencies

- Environmentally friendly R-410A refrigerant reduces ozone depletion.
- An optional hot water generator is available on NSW040, NSW050, NSW060, and NSW075 to generate hot water at considerable savings while improving overall system efficiency.
- High-stability bidirectional expansion valve provides superior performance.
- Efficient scroll compressors operate quietly.
- Oversized coaxial tube water-to-refrigerant heat exchanger increases efficiency.

Standard Features

- Commercial single phase and three phase voltages are available.
- Heavy gauge cabinet
- Quiet scroll compressors in all models
- All interior cabinet surfaces are insulated with ½ in. [12.7 mm] thick 1 ½ lb. [681 g] density, surface coated, acoustic type glass fiber insulation.
- Optional IntelliStart to reduce starting current (208-230/60/1)
- Field switchable control box
- Ultra-compact cabinet
- Multi-density laminate lined compressor blanket designed to suppress low frequency noise.
- Discharge line mufflers to help quiet compressor discharge gas pulsations.

Product Quality

- Heavy-gauge steel cabinets are finished with a durable polyester powder coat paint for long lasting beauty and service.
- The front access panel of each unit is made of a high-density non-metallic material when equipped with standard control.
- All refrigerant brazing is performed in a nitrogen atmosphere.
- The NSW018H and NSW025H are available with load side copper vented double wall coaxial heat exchangers.
- Coaxial heat exchangers, refrigerant suction lines, hot water generator, and all water pipes are fully insulated to reduce condensation problems in low temperature operation.
- Computer controlled deep vacuum and refrigerant charging system.
- All joints are leak detected for maximum leak rate of less than ¼ oz. per year.

- Computer bar code equipped assembly line ensures all components are correct.
- All units are computer run-tested with water to verify both function and performance.
- Safety features include high- and low-pressure refrigerant controls to protect the compressor; hot water high-limit hot water generator pump shutdown.

Easy Maintenance and Service Advantages

- Removable compressor access panels.
- Integrated temperature controls with digital readout and user interface.
- Quick attach wiring harnesses are used throughout for fast servicing.
- High and low pressure refrigerant service ports.

Options and Accessories

- Optional hot water generator with externally mounted pump and water heater plumbing connector.
- Closed loop, source side, circulating pump kit
- Closed loop, load side, circulating pump kit
- Water connection kits
- Geo-Storage Tank (80-120 Gal.)
- IntelliStart
- HydroZone, tank control with outdoor reset

Application Flexibility

- Designed to operate with entering source temperature of 25°F and leaving load temperatures of 40°F to 130°F. See the capacity tables to see allowable operating conditions per model.
- Source side flow rates as low as 1.5 GPM/ton for well water, 50°F [10°C] min. EWT.
- Dedicated heating and heat pump models available.
- Dedicated non-reversible models are shipped as heating only; field convertible to cooling only.
- Modularized unit design and primary/secondary controls for optimum capacity matching and staging.
- Stackable for space conservation (to a maximum 3 units high).
- Compact size allows installation in confined spaces.
- Front or rear plumbing connections.
- Control Panel location is reversible.



Inside the Envision Series

Refrigerant

Envision products all feature zero ozone depletion and low global warming potential R-410A refrigerant.

Cabinet

All units are constructed of corrosion resistant galvanized sheet metal with powder coat paint rated for more than 1000 hours of salt spray. Lift-out access panels provide access to the compressor section from two sides.

Compressors

High efficiency R-410A scroll compressors are used on every model. Scrolls provide both the highest efficiency available and great reliability.

Electrical Box

The control panel is "field" movable from front to back for ease of application. Separate knockouts for low voltage, and two for power on, front and back, allow easy access to the control box. Large 75VA transformer assures adequate controls power for accessories.

Water Connections

Flush mount FPT water connection fittings allow one wrench leak-free connections and do not require a backup wrench. Factory installed water line thermistors can be viewed through the microprocessor interface tool.

Thermostatic Expansion Valve

All Envision models utilize a balanced port bidirectional thermostatic expansion valve (TXV) for refrigerant metering. This allows precise refrigerant flow in a wide range of entering water variation (20 to 120°F [-7 to 49°C]) found in geothermal systems. The TXV is located in the compressor compartment for easy access.



Water-to-Refrigerant Heat Exchanger Coil

Large oversized coaxial refrigerant-to-water heat exchangers provide unparalleled efficiency. The coaxes are designed for low pressure drop and low flow rates. All coaxes are pressure rated to 450 psi water side and 600 psi on the refrigerant side. Refrigerant-to-water heat exchangers will be coated with ThermaShield to prevent condensation in low temperature loop operation. Vented, double walled heat exchanger suitable for potable water systems are standard on 018-025 heating only models.



Service Connections and Serviceability

Two Schrader service ports are provided for each unit. The suction side and discharge side ports are for field charging and servicing access. All valves are 7/16 in. SAE connections.



4-Way Reversing Valve

Envision units feature a reliable all-brass pilot operated refrigerant reversing valve. The reversing valve operation is limited to change of mode by the control to enhance reliability.



IntelliStart

The optional IntelliStart single phase soft starter will reduce the normal start current (LRA) by 60-70%. This allows the heat pump to go off-grid. Using IntelliStart also provides a substantial reduction in light flicker, reduces start-up noise, and improves the compressor's start behavior. IntelliStart is available in a field retrofit kit or as a factory installed option for all Envision and Synergy3D units. IntelliStart is available on 208-230/60/1 voltage.



Water Quality

General

NSW water-to-water heat pumps may be successfully applied in a wide range of residential and light commercial applications. It is the responsibility of the system designer and installing contractor to ensure that acceptable water quality is present and that all applicable codes have been met in these installations. Failure to adhere to the guidelines in the water quality table could result in loss of warranty.

Water Treatment

Do not use untreated or improperly treated water. Equipment damage may occur. The use of improperly treated or untreated water in this equipment may result in scaling, erosion, corrosion, algae or slime. The services of a qualified water treatment specialist should be engaged to determine what treatment, if any, is required. The product warranty specifically excludes liability for corrosion, erosion or deterioration of equipment.

The heat exchangers and water lines in the units are copper or cupronickel tube. There may be other materials in the

building's piping system that the designer may need to take into consideration when deciding the parameters of the water quality.

If an antifreeze or water treatment solution is to be used, the designer should confirm it does not have a detrimental effect on the materials in the system.

Contaminated Water

In applications where the water quality cannot be held to prescribed limits, the use of a secondary or intermediate heat exchanger is recommended to separate the unit from the contaminated water.

The following table outlines the water quality guidelines for unit heat exchangers. If these conditions are exceeded, a secondary heat exchanger is required. Failure to supply a secondary heat exchanger where needed will result in a warranty exclusion for primary heat exchanger corrosion or failure.

Water Quality Guidelines

Material		Copper	90/10 Cupronickel	316 Stainless Steel
pH	Acidity/Alkalinity	7 - 9	7 - 9	7 - 9
Scaling	Calcium and Magnesium Carbonate	(Total Hardness) less than 350 ppm	(Total Hardness) less than 350 ppm	(Total Hardness) less than 350 ppm
Corrosion	Hydrogen Sulfide	Less than 0.5 ppm (rotten egg smell appears at 0.5 ppm)	10 - 50 ppm	Less than 1 ppm
	Sulfates	Less than 125 ppm	Less than 125 ppm	Less than 200 ppm
	Chlorine	Less than 0.5 ppm	Less than 0.5 ppm	Less than 0.5 ppm
	Chlorides	Less than 20 ppm	Less than 125 ppm	Less than 300 ppm
	Carbon Dioxide	Less than 50 ppm	10 - 50 ppm	10 - 50 ppm
	Ammonia	Less than 2 ppm	Less than 2 ppm	Less than 20 ppm
	Ammonia Chloride	Less than 0.5 ppm	Less than 0.5 ppm	Less than 0.5 ppm
	Ammonia Nitrate	Less than 0.5 ppm	Less than 0.5 ppm	Less than 0.5 ppm
	Ammonia Hydroxide	Less than 0.5 ppm	Less than 0.5 ppm	Less than 0.5 ppm
	Ammonia Sulfate	Less than 0.5 ppm	Less than 0.5 ppm	Less than 0.5 ppm
	Total Dissolved Solids (TDS)	Less than 1000 ppm	1000 - 1500 ppm	1000 - 1500 ppm
	LSI Index	+0.5 to -0.5	+0.5 to -0.5	+0.5 to -0.5
Iron Fouling (Biological Growth)	Iron, FE ²⁺ (Ferrous) Bacterial Iron Potential	< 0.2 ppm	< 0.2 ppm	< 0.2 ppm
	Iron Oxide	Less than 1 ppm, above this level deposition will occur	Less than 1 ppm, above this level deposition will occur	Less than 1 ppm, above this level deposition will occur
Erosion	Suspended Solids	Less than 10 ppm and filtered for max. of 600 micron size	Less than 10 ppm and filtered for max. of 600 micron size	Less than 10 ppm and filtered for max. of 600 micron size
	Threshold Velocity (Fresh Water)	< 6 ft/sec	< 6 ft/sec	< 6 ft/sec

NOTES: Grains = ppm divided by 17
mg/L is equivalent to ppm

2/22/12

Standard Board - Control Features

Anti Short Cycle Time

The anti short cycle time consists of a three minute minimum "off" time plus a randomly chosen 0-2 minute additional "off" delay. The random delay is chosen by the control after each compressor shut down. The 3-5 minute startup delay is applied after all compressor shutdowns and also to system startups due to ac power interruption.

Safety Controls

The control board receives separate signals for a high pressure switch for safety, low pressure switch to prevent loss of charge damage, and a low suction temperature for freeze detection. Upon a 30-second measurement of the fault (immediate for high pressure), compressor operation is suspended and the fault will be shown on the display.

Setpoint Temperature Ranges

In Primary mode, the heating temperature setpoint range is adjustable from 60°F (15.5°C) to 130°F (54.4°C) with an adjustable deadband range of 1° - 15°F. The cooling setpoint temperature is adjustable from 25° (-3.9°C) to 85°F (29.4°C) with a fixed non-adjustable deadband of 5°F.

Load Pump Control

There are two options for controlling the load pump, Pump Sampling (PS) or Continuous Pump (C), and these are selectable in the service Menu.

Pump Sampling (PS)

In Primary Mode, the control operates on a 10 minute sample cycle in which the load pump is turned on and run to obtain a meaningful sample of the temperature the load is presenting. If the water temperature measured after the pump has been on for PS minutes (selected and adjusted from the Service Menu) is outside the user selectable deadband amount, dB (also selected and adjusted from the Service Menu), the compressor is turned on and Heating or Cooling is initiated. If the water temperature is within the deadband of the set point when sampled, the pump shuts off and is idle for (10 - PS) minutes when it starts another PS minute sample period. For example, if the PS setting is two minutes, the pump will run for 2 minutes before sampling the load temperature. If the water temperature is within the selected dead band temperature of the set point, the pump will shut off for 10 - 2 = 8 minutes before beginning another pump sampling cycle. Heating deadband is selectable in the Service Menu while the Cooling deadband is non-adjustable and fixed at 5°F.

Continuous Pump Mode (C)

If continuous pump mode (PS=C In Service Menu) is selected, the control will respond immediately to a recognized call or termination of call for heat or cool subject to minimum run times and anti short cycle delays.

Test Mode

Connection of a jumper wire from chassis ground to P3 will place the control in the test mode. This shortens most timing delays for faster troubleshooting. In the Primary Mode the control will respond immediately if a demand is present. The anti-short cycle delay is replaced by a 10 second pump and compressor on delay. Minimum compressor run time becomes 15 seconds. Test mode will remain in effect for a maximum of 15 minutes at any one time should the jumper remain in place.

Fault Conditions

There are two classes of faults, retry faults and no retry faults. Retry faults allow the system to try 2 additional times to establish operation before displaying the fault condition and entering lockout. No-Retry Faults prevent compressor operation for the duration of the fault. If the fault activity ceases while the system is inactive, the fault code is cleared from the display and operation is permitted.

Retry Faults

High pressure, low pressure and freeze detection faults are retried twice before locking the unit out and displaying the fault condition.

High Pressure (HP)

Compressor operation will be disabled immediately when the normally closed high-pressure switch is opened momentarily (set at 600 psi). The LED display shall read "HP" only when the control has completed two retries, and is in lockout. The pump continues to operate throughout the retry period.

Low Pressure (LP)

Compressor operation will be disabled when the normally closed low-pressure switch (set at 40 psi) has opened for 30 continuous seconds (if the bypass period has been satisfied). The Low Pressure switch is bypassed (ignored) for two minutes after startup. The LED display shall read "LP" only when the control has completed two retries, and is in lockout. The pump continues to operate throughout the retry period.

Freeze Detection (FP)

Compressor and loop pumps will be disabled if the control senses that the refrigerant loop temperature drops below the FP value (set in the service menu) for 30 continuous seconds (if the bypass period has been satisfied). If the compressor and the loop pump outputs are disabled because of this condition, the LED display shall read "FP." There is a two (2) minute by-pass timer for the freeze detection at compressor start up.

No-Retry Faults

High Temperature, Water Temperature Probe Open, Water Temperature Probe Closed and Brown Out faults prevent compressor operation for the duration of the

Standard Board - Control Features cont.

fault. If the fault activity ceases while the system is inactive, the fault code is cleared from the display and operation is permitted.

High Temperature

Compressor operation will be disabled when the control senses an entering load side water temperature of 130° F regardless of mode.

Water Temperature Probe Open (PO)

Compressor and pump operation will be disabled when the control senses that the water probe is open or has infinite resistance. The LED display shall read "PO."

Water Temperature Probe Closed (HC)

Compressor and pump operation will be disabled when the control senses that the water probe is closed or has no resistance. The LED display shall read "HC."

Freeze Detection Probe Open (dO)

Compressor and pump operation will be disabled when the control senses that the freeze detection probe is open or has infinite resistance. The LED display shall read "dO."

Freeze Detection Probe Closed (dC)

Compressor and pump operation will be disabled when the control senses that the freeze detection probe is closed or has no resistance. The LED display shall read "dC."

Brown-Out (BO)

All operation will be disabled when the control voltage falls below 18VAC for 10-15 continuous seconds.

Resetting Lockouts

To reset any lockout condition, place the unit into the standby mode for at least 5 seconds. After the lockout has been reset, the fault display will be turned off. Cycling control power will also clear the display. Non-Retry Faults must be cleared for the display and lockout to clear.

Power Down (power outage)

The controller will store its Service Menu settings and current Mode selection in non-volatile memory so that these settings are retained through any power outage. Current operating conditions are not stored and the controller must evaluate its current conditions.

External Control

Primary Mode

In dedicated heating or cooling units, the unit is controlled by the internal controller. Compressor output is determined by the entering load-side water temperature.

The secondary output will be energized if two conditions occur:

1. The initial temperature is greater than **IC** away from the set point.
2. The change in temperature in a given period of time **P** is less than **d**.

In a reversible unit, the unit is controlled by the internal controller. Compressor output is determined by the entering load-side water temperature. For reversible units, the jumper wire must be positioned across **terminals 6** and **7**, (factory default set to this position). Reversible units do not have a secondary output.

NOTES: **SL** in the configuration menu must be set to **0**, (factory default). All parameters should be checked for each application on primary unit, (refer to the parameter table).

Secondary Mode

In dedicated heating or cooling units, secondary mode allows the unit to be controlled by an external source. Compressor output is determined by the Y1 input only.

The secondary output will be energized after the following condition occurs:

1. The change in temperature in a given period of time **P** is less than **d**.

In reversible units, secondary mode allows the unit to be controlled by an external source. Compressor output is determined by the Y1 input and the reversing valve is determined by the O input. In reversible units, the jumper wire must be positioned across terminals 5 and 6. Reversible units do not have a secondary input.

NOTES: **SL** in the configuration menu must be set to **1**. **P** and **d** must be setup for each secondary unit.



WARNING: Reversible units cannot be staged.

Standard Control - Panel Configuration

The control panel allows you to access the service menu on the unit. The control panel has three 7-segment LED screens that display the:

- Water temperature
- Configuration menu

There are six (6) LED indicators that indicate when the SECONDARY OUTPUT is active or the unit is on one of the following modes:

- Standby Mode
- Heating Mode
- Cooling Mode
- Primary (Master) Mode

The control panel has both UP and DOWN (arrow) buttons and a MODE button. The UP and DOWN buttons allow you to change the set point or scroll through the configuration menu. The MODE button allow you to change mode as well as enter and exit parameters while in configuration mode.

Control Panel Configuration

The configuration menu allows you to properly set and adjust all of the unit's operating parameters to fit your application.

To enter configuration mode and configure parameters, follow these procedures:

1. Hold down both the UP and DOWN buttons simultaneously for five seconds, or until the LED screen displays "**LC**".
2. Press the UP or DOWN arrow until "**50**" is displayed.
3. Press the MODE button. The screen should display "**SC**" to indicate the controller is in configuration mode.
4. Once in configuration mode, press the UP or DOWN arrow to scroll through the menu.
5. Press the MODE button to enter the parameter.
(Refer to the parameter table below for a list of configurable parameters.)
6. Once in the parameter, press the UP or DOWN arrow to change the parameter.
7. Press the MODE button to return to the main menu.

NOTE: The controller will exit the configuration mode after 30 seconds if no key is pressed.

Control Panel

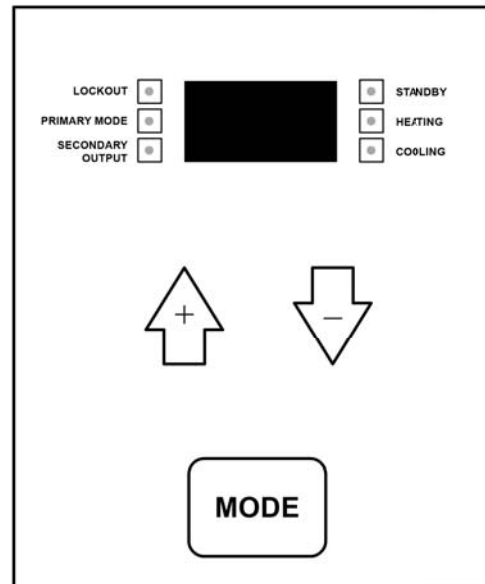

Changing the Setpoint

1. Pressing the UP or DOWN arrow once will display the setpoint.
2. The setpoint will flash.
3. When the setpoint is flashing, the **UP** and **DOWN** arrow will change the setpoint by one degree.
4. In Primary mode, the heating temperature setpoint range is adjustable from 60°F (15.5°C) to 130°F (54.4°C) with an adjustable deadband range of 1° - 15°F. The cooling setpoint temperature is adjustable from 25° (-3.9°C) to 85°F (29.4°C) with a fixed non-adjustable deadband of 5°F.

Standard Control - Panel Configuration cont.

Remote Aquastat Secondary Mode (Y1)

In secondary mode the compressor output is determined by an external aquastat. The compressor shall engage 10 seconds after the Y1 call has been received. The compressor shall de-activate 10 seconds after the Y1 has been removed. The secondary output is controlled by a Derivative Controller. If the change in the water temperature is less than a selected value (d) in a selected period of time (P), the secondary output shall activate.

Parameter Functions and Settings





Parameter	Function	Description	Factory Setting	Range	Increments
SC	Calibrate the Water Sensor	This will allow the temperature displayed to be adjusted to match a temperature reading from an external source.	0°F	-9° to 10°	1
dB	Dead Band (Heating)	This parameter is used to determine when the compressor should be activated. If the temperature is below the setpoint minus the dB value (in heating mode) then the compressor will activate. The cooling deadband is fixed at 5°F and non-adjustable.	1°F	1° to 15°	1
CF	Celsius/ Fahrenheit Selection	This parameter selects the units for which the temperature will be displayed.	F	F or C	N/A
FP	Freeze Detection	There are three settings for this parameter; OL, CL, and P. OL is the open loop setting which corresponds to 32°F (0°C). CL is the closed loop setting which is 15°F (-9°C). P is the process setting which is 5°F (-15°C).	32°F	P,CL,OL	N/A
SL	Primary/ Secondary Setting	Primary mode utilizes an internal aquastat to determine the activity of the compressor. In secondary mode the compressor output is determined by an external aquastat.	0 (Primary)	0 or 1	1 = Secondary 0 = Primary
IC	Initial Condition	This parameter is used to determine the state of the secondary output of the primary unit. If the actual water temperature is greater than the IC value away from the set point, the secondary output will be activated.	10°F	0° to 20°	1°
d	Derivative	This parameter is used to determine the state of the secondary output of the primary and secondary unit. If the change in temperature is less than the d value the secondary output will activate.	1°F	0° to 5°	1°
P	Period	This determines how often the derivative will be calculated.	5 min	1 to 5 min	1 min
PS	Pump Sampling Time Selection	This parameter determines how long the pump is activated before the controller takes a sample of the water temperature. The range of this parameter is from 1 to 5 minutes and is factory set to 3 minutes. The pump can also be set to run continuously when PS is set to C.	3 min	1 to 5 min or C	1 min
Fd	Freeze Detection Display	This displays the current temperature of the freeze detection sensor.	N/A	0° to 130°	N/A

Optional Controls

FX10 Control

The FX10 control provides unparalleled capability in several areas including performance monitoring, energy management, and service diagnosis, and then communicates it all thru standard DDC protocols like N2, Lon and BACnet (MS/TP @ 19,200 Baud Rate).

The most unique feature is integrating the FX10 into the Envision Series as both the heat pump and DDC controller providing both a cost advantage and providing features not typically found on WLHP controls. This integration allows heat pump monitoring sensors, status and service diagnosis faults to be communicated thru the DDC direct to the building automation system (BAS), giving building supervisors detailed and accurate information on every piece of equipment without removing an access panel!

Control	General Description	Application	Display/Interface	Protocol
FX10 	The FX10 microprocessor control is self contained control featuring LP, LOC, HP, LWT, and condensate overflow fault modes can be displayed on BAS system. Optional handheld Medium User Interface (MUI) Control can be used for additional setup or servicing. Program customization is possible.	Cannot be integrated with centralized building automation systems. Software can be customized for specific projects.	Optional Medium User Interface (MUI) can be used as a field service tool.	Standalone
FX10 w/N2 	FX10 Control functions as both unitary heat pump control and DDC communication, therefore detail operational and fault information is available to BAS. Other features are same as FX10 with addition of Johnson Controls N2 compatibility.	Same as FX10 with Johnson Controls N2 BAS compatibility.	Optional Medium User Interface (MUI) can be used as a field service tool.	Johnson Controls N2 network
FX10 w/LonWorks 	FX10 Control functions as both unitary heat pump control and DDC communication, therefore detail operational and fault information is available to BAS. Other features are same as FX10 with addition of LonWorks compatibility.	Same as FX10 with LonWorks BAS compatibility.	Optional Medium User Interface (MUI) can be used as a field service tool.	LonWorks
FX10 w/BACnet 	FX10 Control functions as both unitary heat pump control and DDC communication, therefore detail operational and fault information is available to BAS. Other features are same as FX10 with addition of BACnet compatibility.	Same as FX10 with BACnet BAS compatibility. Due to communication speed, no more than 30 units should be connected to a single trunk of the network.	Optional Medium User Interface (MUI) can be mounted or used as field service tool.	BACnet - MS/TP (19,200 Baud Rate)

Optional Controls - FX10 cont.

FX10 Advanced Control Overview

- The Johnson Controls FX10 board is specifically designed for commercial heat pumps and provides control of the entire unit as well as input ports for Open N2, LonTalk, BACnet (MS/TP @ 19,200 Baud Rate) communication protocols as well as an input port for a user interface. The user interface can be used to aid in diagnostics and unit setup and is optional on all NSW units. A 16-pin low voltage terminal board provides terminals for common field connections. The FX10 Control provides:
 - Operational sequencing
 - High and low-pressure switch monitoring
 - General lockout
 - Freeze Detection Temperature Sensing
 - Lockout mode control
 - Emergency shutdown mode
 - Random start and short cycle protection

Short Cycle Protection

Allows a minimum compressor “off” time of five minutes and a minimum “on” time of two minutes.

Random Start

A delay of 1 to 120 seconds is generated after each power-up to prevent simultaneous startup of all units within a building after the release from an unoccupied cycle or power loss.

Emergency Shutdown

A field-applied dry contact can be used to place the control into emergency shutdown mode. During this mode, all outputs on the board are disabled.

Freeze Detection Temperature Limit

Field selectable for 15°F or 30°F (-9° or -0.56°C)

Installation Options

- Standalone controlled by standard aqua stat
- Integrated into BAS by adding communication module

Accessory Outputs

Quantity 2. Cycled with the compressor. Field selectable for normally open (factory default) or normally closed through the building automation system or user interface.

User Interface

4 x 20 backlit LCD

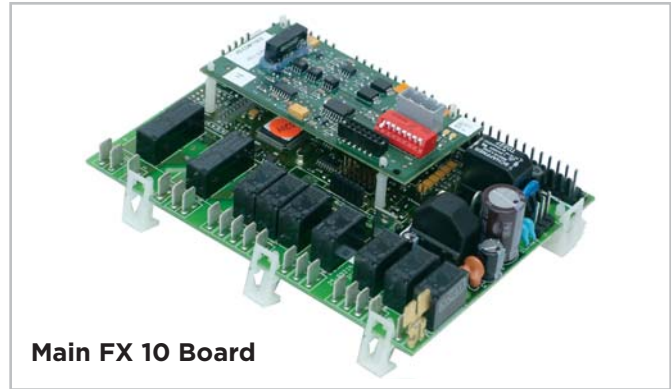

Main FX 10 Board

Optional Plug-in Communication Modules - (compatible with standard BAS protocols)

- Open N2
- LonTalk
- BACnet (MS/TP @ 19,200 Baud Rate, 30 unit max per trunk line)

Display

One local display is optional on all NSW units. Up to 2 displays, either 1 local and 1 remote, or 2 remote. (A 2-display configuration requires identical displays.) Local display can be up to 3 meters from the controller, power supply, and data communication. Remote display can be up to 300 meters from the controller. Remote display must be independently powered with data communication done via 3 pole shielded cable.

Control Timing & Fault Recognition Delays

Lead compressor “ON” delay	90 seconds
(not applicable for single compressor models)	
Minimum compressor “ON” time	2 minutes
(except for fault condition)	
Short cycle delay	5 minutes
Random start delay	0-120 seconds
High pressure fault	<1 second
Low pressure fault	30 seconds
Freeze detection fault	0-30 seconds
Low pressure/freeze fault bypass	2 minutes

NOTES: Refer to Submittal Data SD1981, Application Guide AGFX10, or BACnet Protocol Implementation Conformance Statement for more information.

Optional Controls - FX10 cont.

FX10 Microprocessor and BAS System



The FX10 is a microprocessor based control that not only monitors and controls the heat pump but also can communicate any of this information back to the building automation system (BAS). This means that not only does the control monitor the heat pump at the unit you can also monitor and control many of the features over the BAS. This clearly puts the FX10 in a class of its own.

The control will enumerate all fault conditions (HP, LP, LOC, and Freeze Detection) over a BAS as well as display them on a medium user interface (MUI). HP, LP, and Freeze Detection faults can all be reset over a BAS. A Loss Of Charge fault can not be reset or bypassed until the problem has been corrected. A MUI is invaluable as a service tool for the building service team.

The unit can be commanded to run by applying Y1, Y2, and O commands to the terminal board or commanded through a BAS. The control board is wired with quick connect harnesses for easy field change out of a faulty control board. An alarm history can be viewed through the MUI and will be held in memory until the unit is power cycled.

The FX10 control has unused analog and digital inputs for field installed items such as water temperature or current status switches. The control has unused binary and PWM outputs that can be commanded over the BAS for field use. A Medium User Interface (MUI) for control setup and advanced diagnostics is standard on all NSW units.

Standard Features

- Anti Short Cycle
- High Pressure Protection
- Low Pressure Protection
- Freeze Detection
- Loss of Charge Detection
- Random Start
- Display for diagnostics
- Reset Lockout at disconnect or through BAS
- 2 Accessory outputs
- Optional BAS add-on controls

DDC Operation and Connection

Other optional network protocol boards that can be added to the FX10 are:

- Johnson Control N2
- LonWorks
- BACnet
 - MS/TP @ 19,200 Baud rate
 - Limit devices to 40 on a single trunk line.

Control and Safety Feature Details

Emergency Shutdown

The emergency shutdown mode can be activated by a command from a facility management system or a closed contact on BI-2. The default state for the emergency shutdown data point is off. When the emergency shutdown mode is activated, all outputs will be turned off immediately and will remain off until the emergency shutdown mode is de-activated. The first time the compressor starts after the emergency shutdown mode has been de-activated, there will be a random start delay present.

Lockout Mode

Lockout mode can be activated by any of the following fault signals: refrigerant system high pressure, refrigerant system low pressure, or freeze detection. When any valid fault signal remains continuously active for the length of its recognition delay, the controller will go into fault retry mode, which will turn off the compressor. After the compressor short cycle delay, the compressor will attempt to operate once again. If three consecutive faults occur in 60 minutes, the unit will go into lockout mode, turning off the compressor, enabling the alarm output until the controller is reset. If the control faults due to the low pressure input being open during the pre-compressor startup check, the control will go into lockout mode immediately, disabling the compressor from starting and enabling the alarm output. The lockout condition can be reset by powering down the controller, by a command from the BAS, or by holding the ESC and Return keys on the user interface for 5 seconds.



Optional Controls - FX10 cont.

NSW Freeze Detection

The freeze detection sensor will monitor the liquid refrigerant temperature entering the water coil in the heating mode. If the temperature drops below the freeze detection trip point for the recognition delay period, the condition will be recognized as a fault. The freeze detection trip point will be factory set for 30°F and will be field selectable for 15°F by removing a jumper wire on BI-4 for the source and BI-5 for the load. The freeze detection fault condition will be bypassed for 2 minutes at normal compressor startup to allow the refrigeration circuit to stabilize. If the freeze detection sensor becomes unreliable at any time compressor operation will immediately be suspended until the problem is corrected. This will be displayed as an alarm on the BAS and the MUI. This alarm will be reported as “Water Low Temp Limit”.

High Pressure

The high-pressure switch shall be a normally closed (NC) switch that monitors the systems refrigerant pressure. If the input senses the high-pressure switch is open it must disable the compressor output immediately and count the fault. The compressor minimum on time does not apply if the high-pressure switch opens. The compressor will not restart until the compressor short cycle time delay has been satisfied.

Low Pressure

The low-pressure switch shall be a normally closed (NC) switch that monitors the systems refrigerant pressure. The input shall be checked 5 seconds before compressor start up and then ignored for the first 2 minutes after the compressor output (BO-2) is enabled. If the switch is open continuously for 30 seconds during compressor operation the compressor output (BO-2) will be disabled. The compressor will not restart until the compressor short cycle time delay has been satisfied.

Alarm Outputs

The alarm output will be enabled when the control is in the lockout mode and will be disabled when the lockout is reset.

Test Mode

By holding the ESC and down arrow keys on the MUI for 5 seconds will put the control into test mode. In test mode the random start delay and the compressor fixed on delay time will both be shortened to 5 seconds and the reversing valve will be allowed to cycle without shutting down the compressor. If an MUI is connected to the control LED 8 will flash and the words “Test Mode Enabled” will be shown on the LCD display when the control is in test mode. Test mode will be disabled after a power cycle, 30 minute timeout, or by holding the ESC and Up arrow keys on the MUI.

Sequence of Operation

Power Fail Restart

When the controller is first powered up, the outputs will be disabled for a random start delay. The delay is provided to prevent simultaneous starting of multiple heat pumps. Once the timer expires, the controller will operate normally.

Random Start Delay

This delay will be used after every power failure, as well as the first time the compressor is started after the control exits the unoccupied mode or the emergency shutdown mode. The delay should not be less than 1 second and not longer than 120 seconds. If the control is in test mode the random start delay will be shortened to 5 seconds.

Compressor Minimum On Delay

The compressor minimum on delay will ensure that the compressor output is enabled for a minimum of two (2) minutes each time the compressor output is enabled. This will apply in every instance except in the event the high pressure switch is tripped or emergency shutdown then the compressor output will be disabled immediately.

Compressor Minimum Off Delay Time

The compressor minimum time delay will ensure that the compressor output will not be enabled for a minimum of five (5) minutes after it is disabled. This allows for the system refrigerant pressures to equalize after the compressor is disabled.

Heating Cycle

The control will run the unit in heating mode when there is no command on the O/B terminal on the terminal board.

Cooling Cycle

The control will run the unit in cooling mode when there is a command on the O/B terminal on the terminal board.

MUI Alarm History Reporting

If a fault occurs the fault will be recorded in history for display on the medium user interface in the History Menu. Each fault type will be displayed in the history menu with a number between 0 and 3. A reading of 3+ will mean that fault has occurred more than three times in the past. The history menu can be cleared with a power cycle only. Alarm date and time are not included in the history.

Optional Controls - FX10 cont.

Inputs and Outputs Configuration

Field Selectable Options

Load and Source Freeze Detection Setpoint

The freeze detection setpoint input allows you to adjust the freeze detection setpoint for either the load or source sides of the heat pump. When the jumper is installed on BI-5 the load freeze detection setpoint is factory set for 30°F. When the jumper on BI-5 is removed the load freeze detection setpoint will be 15°F. When the jumper is installed on BI-4 the source freeze detection setpoint is factory set for 30°F. When the jumper on BI-4 is removed the source freeze detection setpoint will be 15°F. **NOTE: Piping circuit must be antifreeze protected to the set levels or the warranty will be voided.**

Accessory Output

The Accessory Outputs will be energized 90 seconds prior to the compressor output being energized. When the compressor output is turned off the accessory outputs will be deactivated immediately. The outputs are selectable for normally open or normally closed operation through the Medium User Interface or through the Building Automation System.

Control Accessories

- A99 Sensor
- MUI (LCD User interface) for diagnostics and commissioning
- MUIK3 - Panel Mount, Portable
- MUIK4 - Wall Mount

Envision Application Notes

The Closed Loop Heat Pump Concept

The basic principle of a water source heat pump is the transfer of heat into water from the space during cooling, or the transfer of heat from water into the space during heating. Extremely high levels of energy efficiency are achieved as electricity is used only to move heat, not to produce it. Using a typical WaterFurnace Envision Series, one unit of electricity will move four to five units of heat.

When multiple water source heat pumps are combined on a common circulating loop, the ultimate in energy efficiency is created: The WaterFurnace units on cooling mode are adding heat to the loop which the units in heating mode can absorb, thus removing heat from the area where cooling is needed, recovering and redistributing that heat for possible utilization elsewhere in the system. In modern commercial structures, this characteristic of heat recovery from core area heat generated by lighting, office equipment, computers, solar radiation, people or other sources, is an important factor in the high efficiency and low operating costs of WaterFurnace closed source heat pump systems.

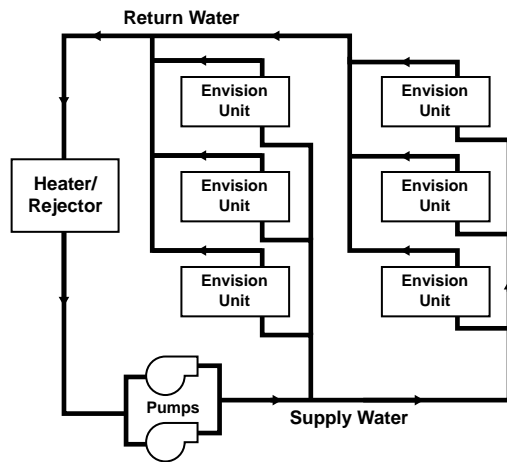

In the event that a building's net heating and cooling requirements create loop temperature extremes, Envision Series units have the extended range capacity and versatility to maintain a comfortable environment for all building areas. Excess heat can be stored for later utilization or be added or removed in one of three ways; by ground-source heat exchanger loops: plate heat exchangers connected to other water sources, or conventional cooler/boiler configurations. Your WaterFurnace representative has the expertise and computer software to assist in determining optimum system type for specific applications.

The Closed Loop Advantage

A properly applied water source heat pump system offers many advantages over other systems. First costs are

low because units can be added to the loop on an "as needed basis"- perfect for speculative buildings. Installed costs are low since units are self-contained and can be located adjacent to the occupied space, requiring minimal ductwork. Maintenance can be done on individual units without system shut-down. Conditions remain comfortable since each unit operates separately, allowing cooling in one area and heating in another. Tenant spaces can be finished and added as needed. Power billing to tenants is also convenient since each unit can be individually metered: each pays for what each uses. Nighttime and/or weekend uses of certain areas are possible without heating or cooling the entire facility. A decentralized system also means if one unit should fault, the rest of the system will continue to operate normally, as well as eliminating air cross-contamination problems and expensive high pressure duct systems requiring an inefficient electric resistance reheat mode.

The Envision Approach

There are a number of proven choices in the type of Envision Series system which would be best for any given application. Most often considered are:

Vertical - Closed Loop/Ground Source



- **Closed Loop/Ground-Source Systems** utilize the stable temperatures of the earth to maintain proper water source temperatures (via vertical or horizontal closed loop heat exchangers) for Envision Series extended range heat pump system. Sizes range from a single unit through many hundreds of units. When net cooling requirements cause closed loop water temperatures to rise, heat is dissipated into the cooler earth through buried high strength plastic pipe "heat exchangers." Conversely if net space heating demands cause loop heat absorption beyond that heat recovered from building core areas, the loop temperature will fall causing heat to be extracted from the earth. Due to the extended loop temperatures, AHRI/ISO 13256-1 Ground Loop Heat Pumps are required for this application.

Envision Application Notes cont.

Because auxiliary equipment such as a fossil fuel boiler and cooling tower are not required to maintain the loop temperature, operating and maintenance costs are very low. Ground-source systems are most applicable in residential and light commercial buildings where both heating and cooling are desired, and on larger envelope dominated structures where core heat recovery will not meet overall heating loads. Both vertical and horizontally installed closed-loops can be used. The land space required for the "heat exchangers" is 100-250 sq. ft./ton on vertical (drilled) installations and 750-1500 sq. ft./ton for horizontal (trenched) installations. Closed loop heat exchangers can be located under parking areas or even under the building itself.

On large multi-unit systems, sizing the closed loop heat exchanger to meet only the net heating loads and assisting in the summer with a closed circuit cooling tower may be the most cost effective choice.

Surface Water - Closed Loop/Ground Source



• ***Closed Loop/Ground-Source Surface Water Systems*** also utilize the stable temperatures of Surface Water to maintain proper water source temperatures for Envision Series extended range heat pump systems. These systems have all of the advantages of horizontal and vertical closed loop systems. Due to the extended loop temperatures, AHRI/ISO 13256-1 Ground Water or Ground Loop Heat Pumps are required for this application.

In cooling dominated structures, the ground-source surface water systems can be very cost effective especially where local building codes require water retention ponds for short term storage of surface run-off. Sizing requirements for the surface water is a minimum of 500 sq. ft./ton of surface area at a minimum depth of 8 feet. WaterFumace should be contacted when designs for heating dominated structures are required.

Plate Heat Exchanger - Closed Loop/Ground Water



• ***Closed Loop/Ground Water Plate Heat Exchanger Systems*** utilize lake, ocean, well water or other water sources to maintain closed loop water temperatures in multi-unit Envision systems. A plate frame heat exchanger isolates the units from any contaminating effects of the water source, and allows periodic cleaning of the heat exchanger during off peak hours.

Operation and benefits are similar to those for ground-source systems. Due to the extended loop temperatures, AHRI/ISO 13256-1 Ground Loop Heat Pumps are required for this application. Closed loop plate heat exchanger systems are applicable in commercial, marine, or industrial structures where the many benefits of a water source heat pump system are desired, regardless of whether the load is heating or cooling dominated.

Envision Application Notes cont.

Cooler/Boiler - Closed Loop



• **Closed Loop /Cooler-Boiler Systems** utilize a closed heat recovering loop with multiple water source heat pumps in the more conventional manner. Typically a boiler is employed to maintain closed loop temperatures above 60°F and a cooling tower to maintain loop temperatures below 90°F. These systems are applicable in medium to large buildings regardless of whether the load is heating or cooling dominated. Due to the moderate loop temperatures, AHRI/ISO 13256-1 Water Loop Heat Pumps are required for this application.

NSW Typical Application Piping

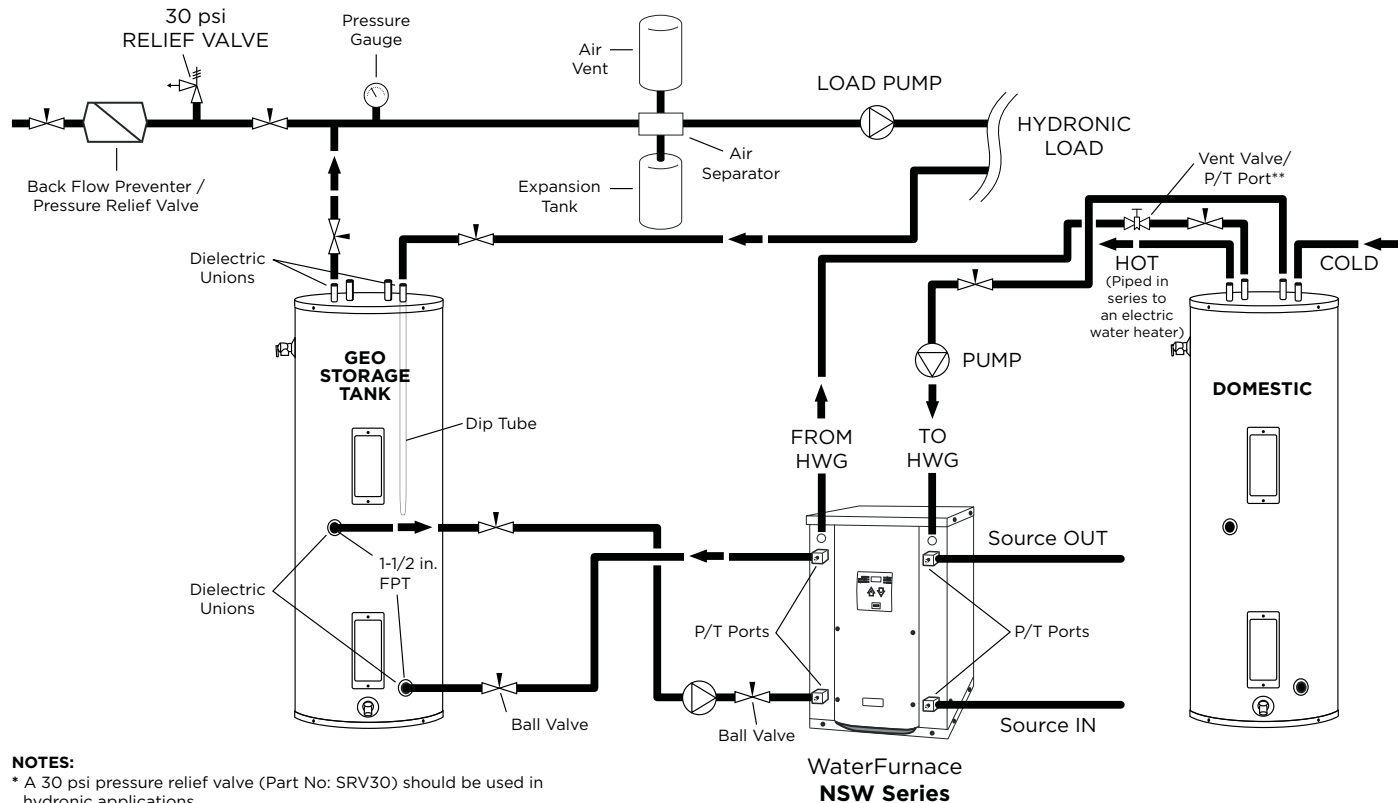

NOTES:

- * A 30 psi pressure relief valve (Part No: SRV30) should be used in hydronic applications.
- ** Vent valve or P/T port at highest point in return line prior to ball valve.

Envision Application Notes cont.

Heating with hot water is versatile because there are many ways of distributing the heat through the building. The options range from heavy cast iron radiators seen in older buildings to modern, baseboard-style convection radiation, and from invisible radiant floor heating to forced air systems using fan coil units.

A boiler is often used to make domestic hot water and to heat swimming pools or hot tubs.

The various distribution systems have all been used successfully with a geothermal heat pump system. When designing or retrofitting an existing hydronic heating system, however, the water temperature produced by the heat pump is a major consideration.

In general, heat pumps are not designed to produce water above 130°F. The efficiency decreases as the temperature difference (ΔT) between the heat load (generally the earth loop) and the supply water (to the distribution system) increases. Figure 1 illustrates the effect of source and load temperatures on the system. The heating capacity of the heat pump also decreases as the temperature difference increases.

When using the various types of hydronic heat distribution systems, the temperature limits of the geothermal system must be considered. In new construction, the distribution system can easily be designed with the temperature limits in mind. In retrofits, care must be taken to address the operating temperature limits of the existing distribution system.

Figure 1: As the ΔT increases, the Coefficient of Performance (COP) decreases. When the system produces 130°F water from a 30°F earth loop, the ΔT is 100°F, and the COP is approximately 2.5. If the system is producing water at 90°F, the ΔT is 60°F and the COP rises to about 3.8, an increase of over 50%.

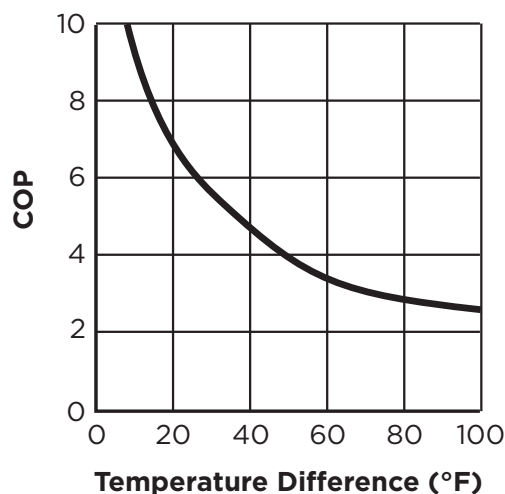

Baseboard Radiation

In existing systems, baseboard radiation is typically designed to operate with 160° to 240°F water or steam. Baseboard units are typically copper pipe with aluminum fins along the length of the pipe, as shown in Figure 2. A decorative cover is normally fitted over the fin tube.

The operation of a baseboard radiation system depends on setting up a convection current in the room: air is warmed by the fin tube, rises and is displaced by cool air.

The heating capacity of a baseboard system is a factor of the area of copper tube and fins exposed to the air and the temperature difference between the air and the fin tube. The velocity and volume of water flowing through the baseboard affects the temperature of the copper and fins. Baseboard units are normally rated in heat output/length of baseboard at a standard water temperature and flow. Manufacturers can provide charts which will give the capacities at temperatures and flows below the standard. Figure 3 shows approximate heating capacities for fin tube radiation using water from 100° to 130°F water.

Baseboards are available using two or three fin tubes tiered above one another in the same cabinet. With the additional surface area, the air can be heated enough to set up a convection current with water temperatures as low as 110° to 130°F (see Figure 3).

It is important to ensure that the heat output of the system is adequate to meet the heat loss of the room or building at the temperatures the geothermal system is capable of producing.

Baseboard radiation is limited to space heating. Cooling is typically provided by a separate, forced air distribution system.

Figure 2: Baseboard radiators are typically constructed of copper tube with closely spaced aluminum fins attached to provide more surface area to dissipate heat. Some of the factors affecting the amount of heat given off by fin tube radiators are the water temperature, water velocity, air temperature, and fin spacing and size.

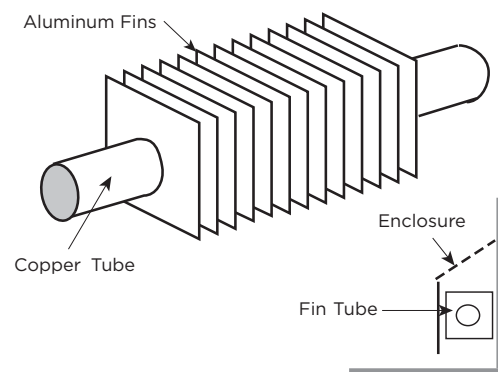

Envision Application Notes cont.

The heating capacity (Btuh/linear foot) of baseboard radiators drop as the water temperature is reduced. The heating capacity of most baseboard radiators is rated using 200°F water, 65°F air temperature. Listed in Figure 3 is the range of heating capacities of baseboard radiators at the standard temperatures and the range of capacities when the temperatures are reduced to the operating range of a heat pump system. Some of the factors that effect the capacity of a radiator are:

- Size of the fins - range from 2.75 in. x 3 in. to 4 in. x 4 in.
- Fin spacing - 24 to 48 foot
- Diameter of copper tube - range from .75 in. to 2 in.
- Fin material - aluminum or steel
- Configuration and height of the enclosure
- Height unit is mounted from the floor
- Water flow through the radiator

Generally, the smaller fins with fewer fins/foot will have lower heating capacity. Larger copper tube diameter and aluminum fins will have a higher capacity. Higher water flow will increase capacity. Adding a second fin tube to the same enclosure will increase the capacity by 50 to 60%. Adding two fin tubes will increase the capacity by 75 to 80%.

Figure 3: Heating output per linear foot

Average Water Temp.	Entering Air Temperatures		
	55°F	65°F	70°F
110°F	190-380	160-320	150-300
120°F	240-480	205-410	195-390
130°F	295-590	265-532	245-490

Cast Iron Radiation

Retrofit applications for hydronic/geothermal heat pump systems are often required to work with existing cast iron radiators or their replacements (see Figure 4). Typically, cast iron radiator systems operate with water temperatures of 125° to 160°F.

These temperatures are higher than geothermal water-to-water heat pumps are capable of providing. Cast iron radiators can work with geothermal systems, provided the heat output of the radiators will meet the maximum heat loss of the building at the lower temperatures.

If the insulation of the building has been upgraded since the original installation, it is possible that the lower temperatures will be able to meet the reduced heat loss of the building.

Figure 4: Baseboard System

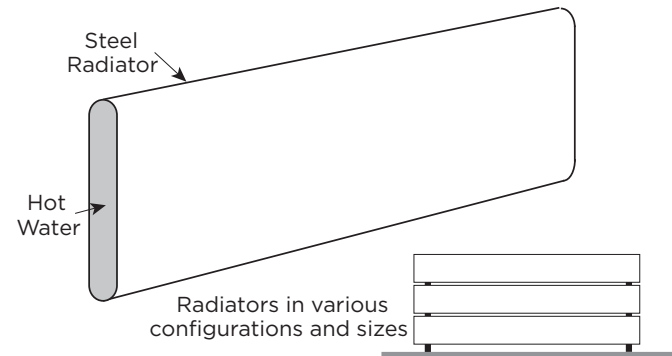

Radiant Floor Heating

Radiant floor heating has been the system of choice in many parts of Europe for some time. Manufacturers have developed tubing designed for installation in concrete floors and raised wood floors.

Floor heating systems have several benefits in residential, commercial and industrial heating applications. In a building with a radiant floor heating system, the entire floor acts as a heat source for the room. People feel comfortable with lower air temperatures if their feet are warm. Typically the space will feel comfortable with air temperatures as low as 65°F. Since the heat loss of a building is directly related to the temperature difference (ΔT) between the inside and outside, a lower ΔT means the heat loss is lower.

Air temperatures in a room with a forced air heating system tend to be warmer nearer to the ceiling than the floor (see Figure 5). The hot air rises and creates a greater pressure imbalance between the inside and outside. The infiltration increases, resulting in a higher heat loss. Air temperatures in a room with radiant floor heating tend to be warmer at the floor than the ceiling, helping to cut down on infiltration in the building. The energy savings in a building with radiant floor heating can range from 10 to 20%.

Figure 5: Temperature Comparison

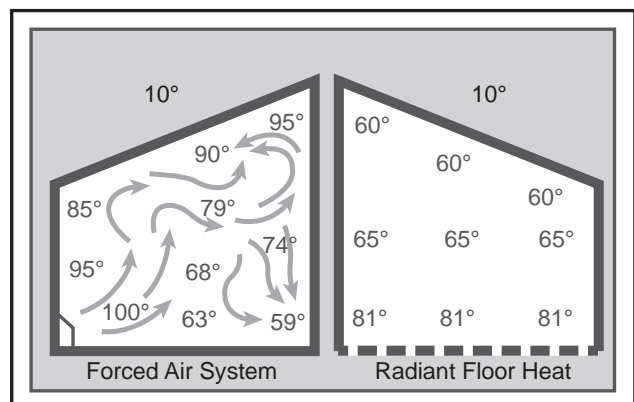

Envision Application Notes cont.

A floor heat system can be designed to heat a building with water temperatures as low as 90°F.

Figure 1 shows how a geothermal system operates more efficiently with a lower ΔT between the source and the load. With only a 60°F temperature difference, a geothermal heat pump will operate at COPs over 4, about 20% higher than a forced air geothermal system in the same installation.

Some of the factors affecting the heating capacity of a floor heating system are as follows:

- The type of finish flooring
- The spacing of the pipe
- The water flow through the pipe
- The temperature of the supply water
- The floor material (wood, concrete or poured Gypcrete™)
- Insulation value under the floor
- The piping layout

The spacing of the pipe in residential applications can vary from 4 in. to 12 in. If the spacing is too large, the temperature of the floor can vary noticeably. In industrial applications, variation in the floor temperature is not as important, and the spacing is related directly to the heat output required.

Radiant floor heating systems work well with geothermal heat pump systems. For efficient operation, the system must be designed with the lowest possible water temperatures.

There are some drawbacks with a radiant floor heating system. Air conditioning is only possible by adding a second system using forced air. This can add substantial cost to an installation where air conditioning is also needed. A separate air handling system is needed to clean the air or to introduce fresh air.

Industrial buildings, especially those with high ceilings and large overhead doors, have an advantage with a radiant floor heating system. Heat is stored in the concrete floor, and when a door is opened, the stored heat is immediately released to the space. The larger the ΔT between the air in the space and the floor, the quicker the floor releases its heat to the space.

Maintenance garages benefit from radiant floor heating systems. Cold vehicles brought into the garage are warmed from underneath. The snow melts off the vehicle and dries much more quickly than when heated from above.

Some pipe manufacturers include an oxygen diffusion barrier in the pipe to prevent oxygen diffusion through the pipe. Good system design and careful installation, however, will eliminate virtually all of the problems encountered with air in the system. Like earth loop design, it is important to design the system to facilitate flushing the air initially and ensuring that the flows can be balanced properly.

Fan Coil Units and Air Handlers

Fan coil units, air handlers, force flow units, etc. are all basically a hot water radiator or coil (usually copper piping with aluminum fins) with a fan or blower to move the air over the coil (see Figure 6). The term “fan coil units” typically applies to smaller units that are installed in the zone or area in which heating (or cooling) is needed. They are available in many different configurations, sizes and capacities. Fan coil units are designed to be connected to a ductwork system and can be used to replace a forced air furnace. Other units are designed for use without ductwork and are mounted in a suspended ceiling space with only a grill showing in place of a ceiling tile. Some can be mounted on a wall under a window, projecting 8 in. to 10 in. into the room or even flush to the wall surface, mounted between wall studs. Some are available with or without finished, decorative cabinets. For industrial applications, inexpensive “unit heaters” are available, with only a coil and an axial fan. Fan coil units and unit heaters are normally available with air handling capacities of 200 to 2,000 cfm.

The term “air handler” normally applies to larger units, mounted in mechanical rooms, mechanical crawl spaces or rooftops. They typically have an air handling capacity of over 2,000 cfm and are available for capacities of up to 50,000 cfm. Air handlers are typically built for a specific installation and are available with many different types of heating and cooling coils. They can include additional coils for heating make-up air, dehumidification and exhaust air heat recovery.

Fan coils and air handlers typically have one or two coils and a blower. Air is heated by hot water circulated through the hot water coil. Chilled water is circulated through the coil if air conditioning is needed. Blowers can be provided to fit various applications, with or without duct-work. Unit heaters typically use axial fans in applications where ductwork is not needed.

Fan coil units and air handlers are used in many different applications. They have been used to heat buildings using water temperatures as low as 90° to 100°F. New systems can be designed to operate very efficiently with a geothermal system.

Envision Application Notes cont.

Figure 6: Fan Coils

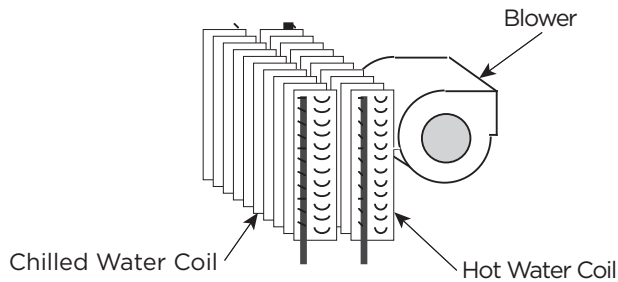

Cooling with a Hydronic System

Cooling a building with an existing radiant hydronic heating system can be a challenge. If baseboard, cast iron radiators or a radiant floor heating system is cooled lower than the dew point, condensation will form on the floor or drip off the radiators.

There is generally minimal or no ductwork for ventilation in existing buildings with radiant hydronic heat. Typically, cooling is provided with separate units where it is needed. This is often done using through-the-wall or window air conditioners, ductless split air conditioning units, or rooftop units.

A water-to-water heat pump system can provide water to ducted or unducted fan coil units. The system can provide chilled water to cool the building, as well as hot water for the heating system when needed.

A limited amount of cooling can be done by circulating chilled water through the piping in the floor. This can be effective in buildings with high solar loads or lighting loads, where much of the heat gain is radiant heat being absorbed by the floor. Cooling fresh air used for ventilation as it is brought into the building, using a chilled water coil, can sometimes provide the additional cooling needed. Care must be taken to avoid cooling the floor below the dew point because condensation may form on the floor.

Buildings with fan coil units and air handlers can generally be easily retrofitted for cooling. Often it is simply a matter of adding a cooling coil to the existing air handlers and fan coil units. Water-to-water heat pumps can provide hot water for the heating coils as well as chilled water for the air conditioning.

Controls

The control of a mechanical system determines how it functions. For the building to work efficiently and comfortably, the building owner or manager must understand what the system is doing and how to control it.

As Figure 1 shows, the efficiency of a heat pump is a factor of the difference in temperature between the source and the load. The heat loss or heat gain of a building varies with the weather and the use of the building. As the outdoor temperature decreases, the heat loss of the building increases. When the ventilation system is started up, the heating or cooling loads increase. As the occupancy increases, lighting or the solar gain increases, and the cooling load increases. At times the building may require virtually no heating or cooling.

With hydronic heating and cooling distribution equipment, whether it is baseboard radiation, fan coil units or radiant floor heating, the output of the equipment is directly related to the temperature and velocity of the water flowing through it. Baseboard radiation puts out approximately 50% less heat with 110°F water than with 130°F water. The same is true with fan coil units and radiant floor heating.

If a system is designed to meet the maximum heat loss of a building with 130°F water, it follows that if the heat loss is 50% lower when the outdoor temperature is higher and the building has high internal gains because of lighting and occupancy, the lower heat loss can be met with 110°F water. This greatly increases the COP of the heat pumps.

The same control strategy is equally effective in cooling. During peak loads, water chilled to 40°F may be needed; at other times 55°F water will provide adequate cooling. Significant increases in the EER can be achieved. Latent loads must always be considered when using warmer water.

Dimensional Data

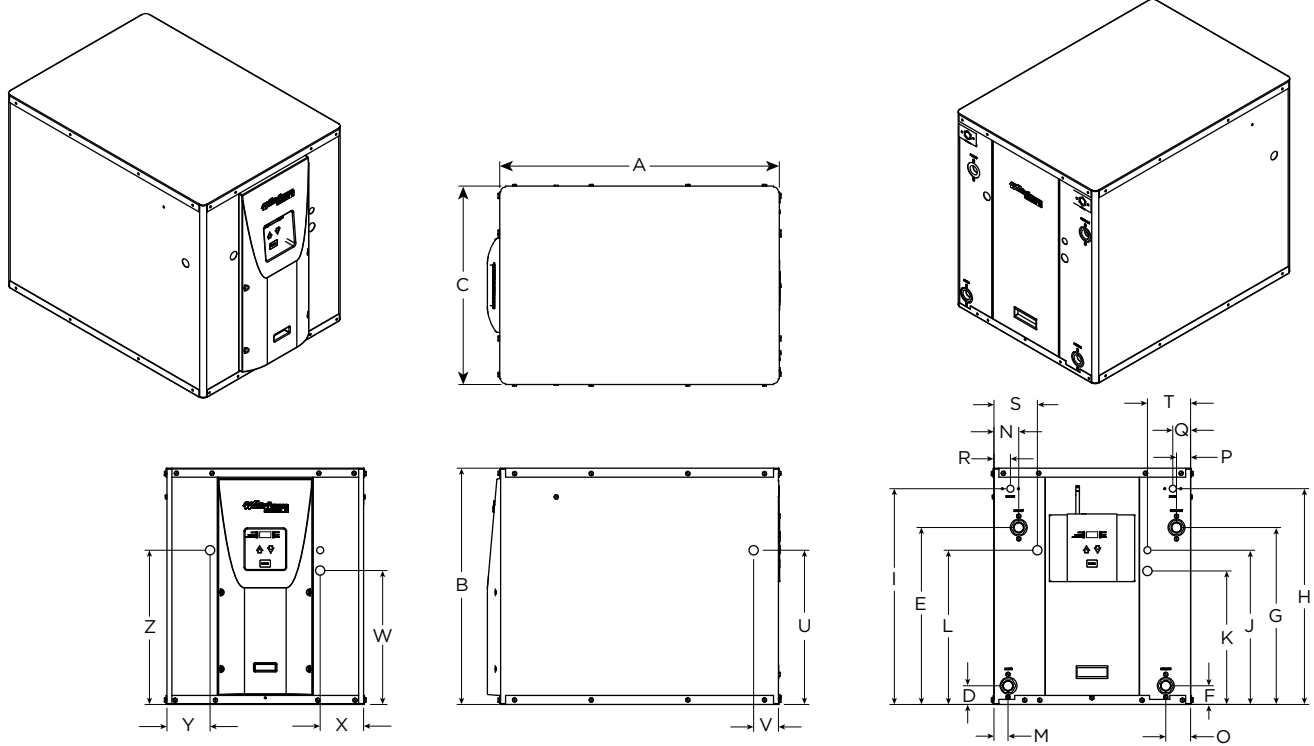

NOTE: Plastic front panel extends 1.4" (3.56 cm) beyond front of cabinet.

6/18/09

Model	Overall Cabinet			Water Connections									Electrical Knockouts			
	A	B	C	D	E	F	G	H	I				J	K	L	
	Depth	Height	Width	Load Liquid In	Load Liquid Out	Source Liquid In	Source Liquid Out	HWG In	HWG Out	Load Water FPT	Source Water FPT	HWG Water FPT	1/2 in. cond Low Voltage	3/4 in. cond Ext Pump	3/4 in. cond Power Supply	
018	in.	23.5	26.1	19.5	10.0	22.2	10.0	22.2	-	-	1 in.	1 in.	-	16.0	14.2	14.2
	cm.	59.7	66.3	49.5	25.4	56.4	25.4	56.4	-	-	25.4 mm	25.4 mm	-	40.6	36.1	36.1
025	in.	23.5	26.1	19.5	10.0	22.2	10.0	22.2	-	-	1 in.	1 in.	-	16.0	14.2	14.2
	cm.	59.7	66.3	49.5	25.4	56.4	25.4	56.4	-	-	25.4 mm	25.4 mm	-	40.6	36.1	36.1
040	in.	31.0	26.2	22.0	2.1	19.6	2.1	19.6	23.9	23.9	1 in.	1 in.	1/2 in.	17.1	14.8	17.1
	cm.	78.7	66.5	55.9	5.3	49.8	5.3	49.8	60.7	60.7	25.4 mm	25.4 mm	12.7 mm	43.4	37.6	43.4
050	in.	31.0	26.2	22.0	2.2	20.6	2.2	20.6	23.9	23.9	1-1/4 in.	1-1/4 in.	1/2 in.	17.1	14.8	17.1
	cm.	78.7	66.5	55.9	5.6	52.3	5.6	52.3	60.7	60.7	31.8 mm	31.8 mm	12.7 mm	43.4	37.6	43.4
060 & 075	in.	31.0	26.2	22.0	2.4	23.0	2.4	23.0	20.6	20.6	1-1/4 in.	1-1/4 in.	1/2 in.	17.1	14.8	17.1
	cm.	78.7	66.5	55.9	6.1	58.4	6.1	58.4	52.3	52.3	31.8 mm	31.8 mm	12.7 mm	43.4	37.6	43.4

Model	Water Connections											Electrical Knockouts			
	M	N	O	P	Q	R	S	T	U	V	W	X	Y	Z	
	Load Liquid In	Load Liquid Out	Source Liquid In	Source Liquid Out	HWG In	HWG Out	Power Supply	Low Voltage	Side Power Supply	Side Power Supply	Ext Pump	Ext Pump	Power Supply	Power Supply	
018	in.	2.4	2.4	2.4	2.4	-	-	3.5	2.9	14.9	2.6	2.1	1.8	2.9	4.1
	cm.	6.1	6.1	6.1	6.1	-	-	8.9	7.4	37.8	6.6	5.3	4.4	7.4	10.4
025	in.	2.4	2.4	2.4	2.4	-	-	3.5	2.9	14.9	2.6	2.1	1.8	2.9	4.1
	cm.	6.1	6.1	6.1	6.1	-	-	8.9	7.4	37.8	6.6	5.3	4.4	7.4	10.4
040	in.	1.6	2.8	2.8	1.6	2.0	1.8	4.8	4.8	17.1	2.8	14.9	4.8	4.8	17.1
	cm.	4.1	7.0	7.0	4.1	5.1	4.6	12.2	12.2	43.4	7.0	37.8	12.2	12.2	43.4
050	in.	1.8	3.6	3.6	1.8	2.1	1.8	4.8	4.8	17.1	2.8	14.9	4.8	4.8	17.1
	cm.	4.6	9.1	9.1	4.6	5.3	4.6	12.2	12.2	43.4	7.1	37.8	12.2	12.2	43.4
060 & 075	in.	1.8	4.0	4.0	1.8	4.2	1.4	4.8	4.8	17.1	2.8	14.9	4.8	4.8	17.1
	cm.	4.6	10.2	10.2	4.6	10.7	3.6	12.2	12.2	43.4	7.1	37.8	12.2	12.2	43.4

NOTE: Plastic front panel extends 1.4 in. (3.56 cm) beyond front of cabinet.

8/6/10

Electrical Data

Model	Rated Voltage	Voltage Min/Max	Compressor			Load Pump	Source Pump	Total Unit FLA	Min Ckt Amp	Maximum Fuse/HACR
			RLA	LRA	LRA*					
018	208-230/60/1	197/254	10.3	51.0	17.9	1.8	5.4	17.5	20.1	30
025	208-230/60/1	197/254	13.5	61.0	21.4	1.8	5.4	20.7	24.1	35
	265/60/1	239/292	10.9	58.0	-	-	-	10.9	13.6	20
	460/60/3	414/506	4.5	27.0	-	-	-	4.5	5.6	10
040	208-230/60/1	197/254	20.0	115.0	40.3	1.8	5.4	27.2	32.2	50
	208-230/60/3	197/254	12.8	95.0	-	-	-	12.8	16.0	25
	460/60/3	414/506	6.4	45.0	-	-	-	6.4	8.0	10
	575/60/3	518/632	5.4	38.0	-	-	-	5.4	6.8	10
050	208-230/60/1	197/254	26.4	134.0	46.9	1.8	5.4	33.6	40.2	60
	265/60/1	239/292	19.9	130.0	-	-	-	19.9	24.9	40
	208-230/60/3	197/254	16.0	110.0	-	-	-	16.0	20.0	35
	460/60/3	414/506	7.8	52.0	-	-	-	7.8	9.8	15
	575/60/3	518/632	5.7	38.9	-	-	-	5.7	7.1	10
060	208-230/60/1	197/254	30.1	145.0	50.8	1.8	5.4	37.3	44.8	70
	208-230/60/3	197/254	17.3	120.0	-	-	-	17.3	21.6	35
	460/60/3	414/506	9.6	70.0	-	-	-	9.6	12.0	20
	575/60/3	518/632	8.0	53.0	-	-	-	8.0	10.0	15
075	208-230/60/1	197/254	26.9	145.0	50.8	1.8	5.4	34.1	40.8	60
	208-230/60/3	197/254	22.4	190.0	-	-	-	22.4	28.0	50
	460/60/3	414/506	12.2	87.0	-	-	-	12.2	15.3	25
	575/60/3	518/632	9.6	62.0	-	-	-	9.6	12.0	20

NOTES: All fuses type "D" time delay (or HACR circuit breaker in USA).
 Source pump amps shown are for up to a 1/2 HP pump.
 Load pumps amps shown are for small circulators.
 *LRA with optional IntelliStart installed (208-230/60/1).

8/6/10

Physical Data

Model	018	025	040	050	060	075
Compressor (1 each)	Scroll					
Factory Charge R410a, oz [kg]	44.0 [1.25]	58.0 [1.64]	70 [1.98]	68 [1.93]	104 [2.95]	110 [3.12]
Coax & Piping Water Volume - gal [l]*	.52 [1.97]	.89 [3.38]	1.0 [3.94]	1.4 [5.25]	1.6 [6.13]	1.6 [6.13]
Weight - Operating, lb [kg]	191 [86.6]	225 [102.1]	290 [131.5]	325 [147.4]	345 [156.5]	345 [156.5]
Weight - Packaged, lb [kg]	213 [96.6]	247 [112.0]	305 [138.3]	340 [154.2]	360 [163.3]	360 [163.3]

NOTE: * Source or load side only.

8/6/10

Antifreeze Correction

Catalog performance can be corrected for antifreeze use. Please use the following table and note the example given.

Antifreeze Type	Antifreeze % by wt	Heating		Cooling		Pressure Drop
		Load	Source	Load	Source	
EWT - °F [°C]		80 [26.7]	30 [-1.1]	50 [10.0]	90 [32.2]	30 [-1.1]
Water	0	1.000	1.000	1.000	1.000	1.000
Ethylene Glycol	10	0.990	0.973	0.976	0.991	1.075
	20	0.978	0.943	0.947	0.979	1.163
	30	0.964	0.917	0.921	0.965	1.225
	40	0.953	0.890	0.897	0.955	1.324
	50	0.942	0.865	0.872	0.943	1.419
Propylene Glycol	10	0.981	0.958	0.959	0.981	1.130
	20	0.967	0.913	0.921	0.969	1.270
	30	0.946	0.854	0.869	0.950	1.433
	40	0.932	0.813	0.834	0.937	1.614
	50	0.915	0.770	0.796	0.922	1.816
Ethanol	10	0.986	0.927	0.945	0.991	1.242
	20	0.967	0.887	0.906	0.972	1.343
	30	0.944	0.856	0.869	0.947	1.383
	40	0.926	0.815	0.830	0.930	1.523
	50	0.907	0.779	0.795	0.911	1.639
Methanol	10	0.985	0.957	0.962	0.986	1.127
	20	0.969	0.924	0.929	0.970	1.197
	30	0.950	0.895	0.897	0.951	1.235
	40	0.935	0.863	0.866	0.936	1.323
	50	0.919	0.833	0.836	0.920	1.399



WARNING: Gray area represents antifreeze concentrations greater than 35% by weight and should be avoided due to the extreme performance penalty they represent.

Antifreeze Correction Example

Antifreeze solution is propylene glycol 20% by weight for the source and methanol 10% for the load. Determine the corrected heating at 30°F source and 80°F load as well as pressure drop at 30°F for an Envision Series NSW050. Also, determine the corrected cooling at 90°F source and 50°F load.

The corrected heating capacity at 30°F/80°F would be:
 $46,700 \text{ MBTUH} \times 0.913 \times 0.985 = 41,998 \text{ MBTUH}$

The corrected cooling capacity at 90°F/50°F would be:
 $44,200 \times 0.969 \times 0.962 = 41,202 \text{ MBTUH}$

The corrected pressure drop at 30°F and 15 GPM would be:
 $5.2 \text{ psi} \times 1.270 = 6.60 \text{ psi}$

AHRI/ISO 13256-2 Performance Ratings

English (IP) Units

Model	Capacity Modulation	Flow Rate		Water Loop Heat Pump				Ground Water Heat Pump				
				Cooling 86°F Source 53.6°F Load		Heating 68°F Source 104°F Load		Cooling 59°F Source 53.6°F Load		Heating 50°F Source 104°F Load		Energy Star Compliant
		Load Gpm	Source Gpm	Capacity Btuh	EER Btuh/W	Capacity Btuh	COP	Capacity Btuh	EER Btuh/W	Capacity Btuh	COP	
018	Single	5	5	16,400	14.0	22,200	4.5	18,800	22.9	18,500	3.7	Yes
025	Single	7	7	23,700	13.6	32,800	4.6	26,700	21.2	27,100	3.8	Yes
040	Single	10	10	35,900	15.5	47,900	4.8	40,900	23.4	39,100	3.9	Yes
050	Single	15	15	49,800	13.9	65,000	4.4	55,600	21.6	54,200	3.7	Yes
060	Single	18	18	55,400	13.6	78,000	4.7	62,500	20.6	63,200	3.8	Yes
075	Single	19	19	66,000	12.3	93,100	4.2	74,100	18.0	77,100	3.5	No

Model	Capacity Modulation	Flow Rate		Ground Loop Heat Pump				
				Cooling 77°F Source 53.6°F Load		Heating 32°F Source 104°F Load		Energy Star Compliant
		Load Gpm	Source Gpm	Capacity Btuh	EER Btuh/W	Capacity Btuh	COP	
018	Single	5	5	17,300	16.6	14,700	3.1	Yes
025	Single	7	7	24,700	16.1	22,000	3.1	Yes
040	Single	10	10	37,700	17.5	30,500	3.1	Yes
050	Single	15	15	51,500	16.4	44,200	3.1	Yes
060	Single	18	18	58,000	16.1	50,100	3.1	Yes
075	Single	19	19	68,400	14.0	61,500	2.9	No

NOTE: All ratings based upon 208V operation.

01/03/12



Pressure Drop

Model	GPM	Pressure Drop (psi)				
		30°F	60°F	80°F	100°F	120°F
018R*	3.0	0.5	0.4	0.4	0.3	0.3
	4.0	1.1	0.9	0.9	0.8	0.8
	5.0	1.6	1.4	1.4	1.3	1.3
	6.0	2.1	1.9	1.9	1.8	1.8
025R*	4.0	0.7	0.6	0.4	0.3	0.3
	5.5	1.3	1.1	0.9	0.7	0.6
	7.0	1.9	1.7	1.5	1.3	1.2
040H/R	5.0	0.9	0.6	0.6	0.5	0.5
	7.5	2.3	2.1	2.0	1.9	1.8
	10.0	3.7	3.5	3.3	3.2	3.0
	12.5	5.0	4.7	4.4	4.2	4.0
050H/R	8.0	1.7	1.4	1.4	1.3	1.3
	11.5	3.6	3.4	3.2	3.0	2.8
	15.0	5.6	5.4	5.0	4.6	4.2
	18.5	8.3	8.1	7.6	7.2	6.8
060H/R	9.0	1.4	1.1	1.0	1.0	0.9
	13.5	4.2	3.9	3.5	3.1	2.7
	18.0	6.9	6.7	6.0	5.2	4.5
	22.5	10.7	10.5	10.0	9.4	8.7
075H/R	10.0	3.2	3.0	2.8	2.7	2.5
	14.5	5.5	5.3	5.1	4.9	4.7
	19.0	7.9	7.6	7.3	7.1	6.8
	23.5	11.5	11.3	11.0	10.8	10.5

NOTE: Temperatures are Entering Water Temperatures
 *Domestic water heating units source side pressure drop and reversible units load and source pressure drop.

8/9/10

NSW Vented Only Load Side

Model	GPM	Pressure Drop (psi)			
		60°F	80°F	100°F	120°F
018H	3.0	0.5	0.4	0.4	0.3
	4.0	1.4	1.3	1.2	1.2
	5.0	2.2	2.1	2.1	2.0
	6.0	3.0	2.9	2.9	2.8
025H	4.0	1.3	1.3	1.2	1.2
	5.5	3.0	2.9	2.8	2.7
	7.0	4.6	4.4	4.3	4.1
	8.5	6.7	6.5	6.4	6.2

NOTE: Temperatures are Entering Water Temperatures.
 Double wall vented coax for heating potable water

7/13/09

Reference Calculations

<p>Heating Calculations:</p> $\text{LWT} = \text{EWT} - \frac{\text{HE}}{\text{GPM} \times \text{C}^*}$ $\text{HE} = \text{C}^* \times \text{GPM} \times (\text{EWT} - \text{LWT})$	<p>Cooling Calculations:</p> $\text{LWT} = \text{EWT} + \frac{\text{HR}}{\text{GPM} \times \text{C}^*}$ $\text{HR} = \text{C}^* \times \text{GPM} \times (\text{LWT} - \text{EWT})$
--	--

NOTE: * C = 500 for pure water, 485 for brine.

Legend and Notes

Abbreviations and Definitions

ELT = entering load fluid temperature to heat pump	kW = kilowatts
SWPD = source coax water pressure drop	EST = entering source fluid temperature to heat pump
LLT = leaving load fluid temperature from heat pump	HE = heat extracted in MBTUH
PSI = pressure drop in pounds per square inch	LST = leaving source fluid temperature from heat pump
LGPM = load flow in gallons per minute	HC = total heating capacity in MBTUH
FT HD = pressure drop in feet of head	COP = coefficient of performance, heating [HC/kW x 3.413]
LWPD = load coax water pressure drop	EER = energy efficiency ratio, cooling
LWT = leaving water temperature	TC = total cooling capacity in MBTUH
EWT = entering water temperature	HR = heat rejected in MBTUH
Brine = water with a freeze inhibiting solution	

Notes to Performance Data Tables

The following notes apply to all performance data tables:

- Three flow rates are shown for each unit. The lowest flow rate shown is used for geothermal open loop/well water systems with a minimum of 50°F EST. The middle flow rate shown is the minimum geothermal closed loop flow rate. The highest flow rate shown is optimum for geothermal closed loop systems and the suggested flow rate for boiler/tower applications.
- Entering water temperatures below 40°F assumes 15% antifreeze solution.
- Interpolation between ELT, EST, and GPM data is permissible.
- Operation in the gray areas is not recommended.

NSW018 - Performance Data

Cooling Capacity

Source		Load Flow-3 GPM							Load Flow-4 GPM							Load Flow-5 GPM						
EST °F	Flow GPM	ELT °F	LLT °F	TC MBTUH	Power kW	HR MBTUH	EER	LST °F	LLT °F	TC MBTUH	Power kW	HR MBTUH	EER	LST °F	LLT °F	TC MBTUH	Power kW	HR MBTUH	EER	LST °F		
30	3	50	37.8	17.8	0.60	19.8	29.7	43.6	40.1	18.1	0.61	20.1	29.8	43.8	42.5	18.3	0.61	20.4	30.0	44.0		
		70	56.8	19.3	0.59	21.3	32.5	44.6	59.3	19.4	0.60	21.5	32.6	44.8	61.9	19.6	0.60	21.6	32.7	44.9		
		90	75.8	20.7	0.59	22.7	35.3	45.6	78.6	20.8	0.59	22.8	35.4	45.7	81.4	20.9	0.59	22.9	35.4	45.7		
		110	94.7	22.2	0.58	24.2	38.3	46.6	97.8	22.2	0.58	24.2	38.3	46.6	100.8	22.2	0.58	24.2	38.3	46.6		
	4	50	37.7	18.0	0.58	19.9	30.9	40.9	40.0	18.2	0.58	20.2	31.2	41.1	42.4	18.4	0.59	20.4	31.5	41.2		
		70	56.7	19.3	0.57	21.3	33.8	41.7	59.3	19.5	0.57	21.4	34.0	41.8	61.9	19.6	0.58	21.6	34.1	41.9		
		90	75.8	20.7	0.56	22.6	36.7	42.4	78.6	20.8	0.56	22.7	36.8	42.5	81.4	20.9	0.57	22.8	36.9	42.5		
		110	94.9	22.0	0.56	23.9	39.6	43.2	97.9	22.1	0.56	23.9	39.7	43.2	100.9	22.1	0.56	24.0	39.8	43.2		
	5	50	37.6	18.1	0.56	20.0	32.3	38.3	40.0	18.3	0.56	20.2	32.7	38.3	42.4	18.5	0.56	20.4	33.0	38.4		
		70	56.7	19.3	0.55	21.2	35.2	38.7	59.3	19.5	0.55	21.4	35.5	38.8	61.9	19.7	0.55	21.5	35.8	38.9		
		90	75.9	20.6	0.54	22.4	38.1	39.2	78.6	20.7	0.54	22.5	38.3	39.3	81.4	20.8	0.54	22.7	38.6	39.4		
		110	95.0	21.8	0.53	23.6	41.1	39.7	98.0	21.9	0.53	23.7	41.3	39.8	100.9	22.0	0.53	23.8	41.5	39.8		
50	3	50	38.4	16.9	0.80	19.6	22.9	63.4	40.5	17.3	0.80	20.0	23.3	63.8	42.7	17.8	0.80	20.5	23.7	64.1		
		70	56.3	19.9	0.80	22.6	26.5	65.5	58.9	20.2	0.80	22.9	26.8	65.8	61.5	20.6	0.80	23.3	27.2	66.0		
		90	74.3	22.9	0.80	25.6	30.1	67.6	77.3	23.1	0.79	25.8	30.4	67.8	80.4	23.4	0.79	26.1	30.7	67.9		
		110	92.2	25.9	0.80	28.6	33.8	69.7	95.7	26.1	0.79	28.8	34.0	69.8	99.2	26.2	0.79	28.9	34.2	69.9		
	4	50	38.3	17.0	0.77	19.6	22.0	60.8	40.5	17.4	0.77	20.0	22.6	61.0	42.6	17.8	0.77	20.5	23.1	61.2		
		70	56.3	19.9	0.77	22.5	26.0	62.4	58.9	20.3	0.76	22.9	26.5	62.6	61.5	20.6	0.76	23.2	27.0	62.8		
		90	74.3	22.9	0.76	25.5	30.2	64.0	77.3	23.1	0.76	25.7	30.5	64.2	80.4	23.4	0.76	25.9	30.9	64.3		
		110	92.2	25.9	0.75	28.4	34.4	65.7	95.7	26.0	0.75	28.6	34.6	65.7	99.2	26.1	0.75	28.7	34.8	65.8		
	5	50	38.2	17.1	0.75	19.7	24.7	58.1	40.4	17.5	0.75	20.0	25.3	58.3	42.6	17.9	0.74	20.4	25.9	58.4		
		70	56.3	20.0	0.74	22.5	28.8	59.3	58.9	20.3	0.73	22.8	29.2	59.4	61.5	20.6	0.73	23.1	29.7	59.5		
		90	74.3	22.9	0.72	25.4	33.0	60.5	77.3	23.1	0.72	25.6	33.3	60.5	80.4	23.3	0.72	25.8	33.6	60.6		
		110	92.3	25.8	0.71	28.2	37.3	61.6	95.8	25.9	0.71	28.3	37.5	61.7	99.3	26.1	0.71	28.5	37.7	61.7		
70	3	50	39.1	15.9	0.99	19.3	16.1	83.3	41.0	16.6	0.99	19.9	16.7	83.7	42.9	17.2	0.99	20.6	17.4	84.1		
		70	55.9	20.5	1.00	23.9	20.5	86.4	58.5	21.0	1.00	24.4	21.1	86.8	61.1	21.5	0.99	24.9	21.7	87.1		
		90	Operation not recommended																			
	4	50	39.0	16.0	0.97	19.3	16.6	80.6	40.9	16.6	0.96	19.9	17.3	80.9	42.9	17.3	0.96	20.5	18.1	81.3		
		70	55.9	20.6	0.96	23.8	21.4	83.1	58.5	21.1	0.96	24.3	22.0	83.4	61.1	21.6	0.95	24.8	22.6	83.7		
		90	Operation not recommended																			
		110	Operation not recommended																			
	5	50	38.9	16.1	0.94	19.3	17.1	78.0	40.9	16.7	0.93	19.9	18.0	78.2	42.9	17.3	0.92	20.4	18.8	78.4		
		70	55.8	20.7	0.92	23.8	22.4	79.8	58.5	21.1	0.92	24.2	23.0	80.0	61.1	21.6	0.91	24.7	23.7	80.2		
		90	Operation not recommended																			
		110	Operation not recommended																			
	90	3	50	40.4	14.0	1.30	18.4	11.8	102.7	42.1	14.5	1.30	19.0	12.3	103.0	43.8	15.1	1.30	19.5	12.7	103.4	
70			57.4	18.3	1.30	22.7	15.3	105.6	59.8	18.7	1.30	23.2	15.7	105.9	62.1	19.2	1.30	23.6	16.1	106.2		
90			Operation not recommended																			
110			Operation not recommended																			
4		50	40.3	14.1	1.27	18.4	11.2	100.1	42.0	14.6	1.26	19.0	11.6	100.4	43.8	15.2	1.26	19.5	12.0	100.7		
		70	57.3	18.4	1.26	22.7	14.6	102.5	59.7	18.9	1.26	23.1	15.0	102.7	62.0	19.3	1.26	23.6	15.4	103.0		
		90	Operation not recommended																			
		110	Operation not recommended																			
5		50	40.2	14.3	1.24	18.5	12.6	97.6	42.0	14.8	1.23	18.9	13.2	97.8	43.7	15.3	1.23	19.4	13.7	98.0		
		70	57.2	18.6	1.22	22.7	16.6	99.4	59.6	19.0	1.21	23.1	17.1	99.5	62.0	19.4	1.21	23.5	17.5	99.7		
		90	Operation not recommended																			
		110	Operation not recommended																			
110	3	50	41.7	12.1	1.60	17.6	7.6	122.1	43.2	12.5	1.61	18.0	7.8	122.4	44.7	12.9	1.61	18.4	8.0	122.6		
		70	59.0	16.1	1.60	21.5	10.0	124.8	61.0	16.5	1.60	21.9	10.3	125.1	63.1	16.8	1.61	22.3	10.5	125.3		
		90	Operation not recommended																			
	4	50	41.6	12.3	1.57	17.6	7.8	119.7	43.1	12.7	1.57	18.0	8.1	119.9	44.6	13.1	1.57	18.4	8.3	120.1		
		70	58.8	16.3	1.56	21.6	10.5	121.9	60.9	16.6	1.56	22.0	10.7	122.1	63.0	17.0	1.56	22.3	10.9	122.3		
		90	Operation not recommended																			
		110	Operation not recommended																			
	5	50	41.5	12.4	1.53	17.6	8.1	117.3	43.0	12.8	1.53	18.0	8.4	117.4	44.6	13.2	1.53	18.4	8.6	117.6		
		70	58.7	16.5	1.51	21.6	10.9	118.9	60.8	16.8	1.51	22.0	11.1	119.1	62.9	17.2	1.51	22.4	11.4	119.2		
		90	Operation not recommended																			
		110	Operation not recommended																			

NSW018 - Performance Data cont.

Heating Capacity

Source		Load Flow-3 GPM							Load Flow-4 GPM							Load Flow-5 GPM						
EST °F	Flow GPM	ELT °F	LLT °F	HC MBTUH	Power kW	HE MBTUH	COP	LST °F	LLT °F	HC MBTUH	Power kW	HE MBTUH	COP	LST °F	LLT °F	HC MBTUH	Power kW	HE MBTUH	COP	LST °F		
25	4	60	Operation not recommended																			
		80	Operation not recommended																			
		100	Operation not recommended																			
		120	Operation not recommended																			
	5	60	69.8	14.2	0.90	11.1	4.62	20.4	67.4	14.3	0.88	11.3	4.76	20.3	65.9	14.4	0.86	11.5	4.91	20.3		
		80	89.4	13.7	1.21	9.6	3.31	21.1	87.1	13.8	1.19	9.7	3.38	21.0	85.7	13.9	1.17	9.9	3.46	20.9		
		100	109.1	13.2	1.53	8.0	2.53	21.7	106.8	13.3	1.51	8.1	2.58	21.6	105.5	13.3	1.49	8.3	2.63	21.6		
		120	128.7	12.7	1.84	6.4	2.02	22.4	126.6	12.8	1.82	6.5	2.05	22.3	125.3	12.8	1.80	6.7	2.08	22.3		
30		3	60	70.4	15.1	0.91	12.0	4.86	21.8	68.3	15.2	0.90	12.1	4.96	21.7	66.3	15.2	0.88	12.2	5.06	21.6	
			80	90.0	14.5	1.22	10.4	3.48	22.9	88.0	14.6	1.21	10.5	3.55	22.8	86.0	14.6	1.19	10.6	3.61	22.7	
			100	109.6	14.0	1.54	8.7	2.66	24.0	107.7	14.0	1.52	8.8	2.71	23.9	105.8	14.1	1.49	9.0	2.76	23.8	
			120	129.2	13.4	1.85	7.1	2.12	25.1	127.4	13.5	1.83	7.2	2.16	25.0	125.6	13.5	1.80	7.4	2.20	24.9	
	4	60	70.7	15.5	0.91	12.4	5.02	23.2	68.6	15.6	0.89	12.6	5.14	23.2	66.5	15.7	0.88	12.7	5.26	23.1		
		80	90.2	14.9	1.22	10.7	3.58	24.2	88.2	15.0	1.20	10.9	3.66	24.1	86.2	15.0	1.18	11.0	3.75	24.0		
		100	109.8	14.3	1.53	9.0	2.73	25.1	107.9	14.3	1.50	9.2	2.79	25.0	105.9	14.4	1.48	9.3	2.85	24.9		
		120	129.4	13.7	1.85	7.4	2.17	26.0	127.5	13.7	1.81	7.5	2.21	25.9	125.6	13.7	1.78	7.6	2.26	25.8		
		5	60	70.9	15.9	0.90	12.8	5.18	24.7	68.8	16.1	0.89	13.0	5.32	24.6	66.7	16.2	0.87	13.2	5.46	24.5	
			80	90.5	15.2	1.21	11.1	3.68	25.4	88.4	15.3	1.19	11.3	3.78	25.3	86.4	15.4	1.16	11.5	3.89	25.3	
			100	110.0	14.6	1.53	9.4	2.80	26.1	108.0	14.6	1.49	9.5	2.87	26.1	106.0	14.7	1.46	9.7	2.95	26.0	
			120	129.6	13.9	1.84	7.6	2.21	26.9	127.6	13.9	1.80	7.8	2.27	26.8	125.7	13.9	1.75	7.9	2.33	26.7	
50	3	60	73.5	19.7	0.90	16.6	6.46	38.6	70.9	19.8	2.74	10.4	4.71	42.8	68.2	20.0	4.59	4.3	2.97	47.1		
		80	93.0	18.9	1.21	14.7	4.58	39.9	90.4	19.0	2.43	10.7	3.48	42.7	87.9	19.1	3.65	6.6	2.37	45.4		
		100	112.4	18.1	1.52	12.9	3.48	41.2	110.0	18.1	2.12	10.9	2.85	42.5	107.5	18.2	2.71	9.0	2.21	43.8		
		120	131.9	17.3	1.84	11.0	2.76	42.4	129.5	17.3	1.80	11.1	2.82	42.3	127.2	17.4	1.77	11.3	2.88	42.2		
	4	60	73.9	20.2	0.89	17.1	6.62	40.7	71.2	20.4	1.81	14.2	3.31	42.7	68.5	20.6	2.72	11.3	2.22	44.8		
		80	93.3	19.3	1.21	15.2	4.69	41.7	90.7	19.5	1.80	13.3	3.16	43.0	88.1	19.6	2.40	11.4	2.40	44.4		
		100	112.7	18.4	1.52	13.2	3.55	42.8	110.2	18.5	1.80	12.4	3.02	43.4	107.7	18.6	2.08	11.5	2.63	44.0		
		120	132.1	17.6	1.83	11.3	2.81	43.8	129.7	17.6	1.80	11.5	2.87	43.7	127.3	17.7	1.76	11.7	2.94	43.6		
		5	60	74.2	20.7	0.89	17.7	6.83	42.7	71.5	21.0	0.87	18.0	7.12	42.6	68.7	21.2	0.85	18.3	7.41	42.4	
			80	93.6	19.8	1.20	15.6	4.82	43.5	90.9	19.9	1.17	15.9	4.99	43.4	88.3	20.1	1.15	16.2	5.17	43.3	
			100	112.9	18.8	1.52	13.6	3.64	44.4	110.4	18.9	1.48	13.9	3.75	44.3	107.8	19.0	1.45	14.1	3.87	44.2	
			120	132.3	17.9	1.83	11.6	2.86	45.2	129.8	17.9	1.79	11.8	2.94	45.1	127.4	18.0	1.75	12.0	3.02	45.1	
70	3	60	76.6	24.2	0.88	21.2	8.06	55.4	73.4	24.5	4.59	8.8	4.46	64.0	70.2	24.7	8.30	-3.6	0.87	72.5		
		80	95.9	23.2	1.19	19.1	5.69	56.9	92.8	23.4	3.65	10.9	3.41	62.5	89.7	23.5	6.11	2.7	1.13	68.2		
		100	115.2	22.1	1.51	17.0	4.30	58.3	112.2	22.3	2.72	13.0	2.99	61.1	109.2	22.4	3.93	9.0	1.67	63.8		
		120	134.5	21.1	1.82	14.9	3.40	59.8	131.6	21.2	1.78	15.1	3.48	59.6	128.7	21.2	1.74	15.3	3.57	59.5		
	4	60	77.1	24.9	0.88	21.8	8.27	58.1	73.8	25.2	2.72	15.9	2.71	62.2	70.5	25.5	4.56	9.9	1.64	66.4		
		80	96.3	23.7	1.19	19.6	5.82	59.3	93.1	23.9	2.41	15.7	2.91	62.0	90.0	24.2	3.62	11.8	1.96	64.8		
		100	115.5	22.6	1.51	17.4	4.39	60.5	112.5	22.7	2.09	15.6	3.18	61.8	109.4	22.9	2.68	13.7	2.50	63.1		
		120	134.7	21.5	1.82	15.2	3.45	61.7	131.8	21.5	1.78	15.4	3.54	61.6	128.9	21.6	1.74	15.7	3.64	61.4		
		5	60	77.5	25.5	0.88	22.5	8.49	60.7	74.2	25.9	0.85	22.9	8.93	60.5	70.8	26.2	0.82	23.4	9.36	60.3	
			80	96.7	24.3	1.19	20.2	5.96	61.7	93.5	24.5	1.16	20.6	6.20	61.5	90.2	24.8	1.13	21.0	6.45	61.4	
			100	115.8	23.0	1.51	17.9	4.48	62.6	112.7	23.2	1.47	18.2	4.63	62.5	109.6	23.4	1.43	18.5	4.78	62.4	
			120	135.0	21.8	1.82	15.6	3.51	63.6	132.0	21.9	1.78	15.8	3.61	63.5	129.1	22.0	1.74	16.1	3.70	63.4	
90	3	60	79.6	28.5	0.88	25.5	9.49	72.5	75.6	28.4	0.85	25.5	9.84	72.5	71.6	28.2	0.81	25.4	10.20	72.5		
		80	98.6	27.1	1.18	23.0	6.70	74.2	94.9	27.1	1.15	23.1	6.92	74.1	91.1	27.0	1.11	23.2	7.14	74.0		
		100	Operation not recommended																			
		120	Operation not recommended																			
	4	60	80.1	29.2	0.88	26.2	9.72	75.7	76.0	29.0	0.85	26.1	10.05	75.7	71.9	28.8	0.81	26.0	10.40	75.8		
		80	99.0	27.7	1.19	23.6	6.84	77.1	95.2	27.6	1.15	23.7	7.05	77.0	91.4	27.6	1.11	23.8	7.28	77.0		
		100	Operation not recommended																			
		120	Operation not recommended																			
		5	60	80.5	29.9	0.88	26.9	9.96	78.9	76.3	29.6	0.85	26.7	10.28	79.0	72.1	29.3	0.81	26.5	10.60	79.1	
			80	99.4	28.2	1.19	24.2	6.97	80.0	95.5	28.2	1.15	24.2	7.19	80.0	91.6	28.1	1.11	24.3	7.42	80.0	
			100	Operation not recommended																		
			120	Operation not recommended																		

NSW018 DHW - Performance Data cont.

Heating Only Capacity

Source		Load Flow-3 GPM							Load Flow-4 GPM							Load Flow-5 GPM						
EST °F	Flow GPM	ELT °F	LLT °F	HC MBTUH	Power kW	HE MBTUH	COP	LST °F	LLT °F	HC MBTUH	Power kW	HE MBTUH	COP	LST °F	LLT °F	HC MBTUH	Power kW	HE MBTUH	COP	LST °F		
25	4	60	Operation not recommended																			
		80																				
		100																				
		120																				
	5	60	70.0	14.5	0.97	11.2	4.38	20.4	67.6	14.7	0.95	11.4	4.52	20.3	66.1	14.8	0.93	11.6	4.66	20.2		
		80	89.7	14.1	1.30	9.7	3.19	21.0	87.4	14.3	1.28	9.9	3.27	20.9	85.9	14.4	1.26	10.1	3.36	20.8		
		100	109.5	13.8	1.62	8.2	2.48	21.6	107.2	13.9	1.60	8.4	2.54	21.5	105.8	14.0	1.58	8.6	2.59	21.5		
		120	129.2	13.4	1.95	6.7	2.01	22.2	127.0	13.5	1.93	6.9	2.05	22.1	125.6	13.6	1.91	7.1	2.09	22.1		
30	3	60	70.4	15.2	0.97	11.9	4.59	21.8	68.4	15.4	0.95	12.1	4.74	21.7	66.4	15.5	0.93	12.3	4.88	21.5		
		80	90.2	14.9	1.30	10.4	3.35	22.8	88.2	15.0	1.28	10.6	3.43	22.7	86.2	15.1	1.26	10.8	3.52	22.6		
		100	110.0	14.5	1.63	9.0	2.61	23.8	108.0	14.7	1.61	9.2	2.67	23.7	106.1	14.8	1.59	9.3	2.72	23.6		
		120	129.8	14.2	1.96	7.5	2.12	24.8	127.8	14.3	1.94	7.7	2.16	24.7	125.9	14.4	1.92	7.8	2.20	24.6		
	4	60	70.7	15.6	0.97	12.3	4.71	23.3	68.6	15.8	0.95	12.5	4.86	23.2	66.6	15.9	0.93	12.7	5.01	23.1		
		80	90.4	15.2	1.30	10.8	3.43	24.1	88.4	15.3	1.28	11.0	3.51	24.0	86.4	15.5	1.26	11.2	3.60	23.9		
		100	110.2	14.8	1.63	9.2	2.66	25.0	108.2	14.9	1.61	9.4	2.71	24.9	106.2	15.0	1.59	9.6	2.77	24.8		
		120	129.9	14.4	1.96	7.7	2.15	25.8	127.9	14.5	1.94	7.9	2.19	25.7	126.0	14.6	1.92	8.0	2.23	25.6		
	5	60	71.0	16.0	0.97	12.7	4.83	24.8	68.9	16.2	0.95	12.9	4.98	24.7	66.7	16.3	0.93	13.1	5.14	24.6		
		80	90.7	15.5	1.30	11.1	3.50	25.4	88.6	15.7	1.28	11.3	3.59	25.3	86.5	15.8	1.26	11.5	3.68	25.3		
		100	110.4	15.1	1.63	9.5	2.71	26.1	108.3	15.2	1.61	9.7	2.76	26.0	106.3	15.2	1.58	9.8	2.82	25.9		
		120	130.0	14.6	1.96	7.9	2.18	26.7	128.0	14.7	1.94	8.0	2.22	26.7	126.1	14.7	1.91	8.2	2.26	26.6		
	50	3	60	73.4	19.6	0.98	16.2	5.87	38.9	70.8	19.8	0.95	16.5	6.10	38.7	68.2	20.0	0.93	16.8	6.33	38.5	
			80	93.0	18.9	1.31	14.4	4.23	40.1	90.5	19.1	1.28	14.7	4.37	39.9	87.9	19.3	1.25	15.0	4.51	39.7	
			100	112.5	18.3	1.64	12.7	3.26	41.3	110.1	18.4	1.61	12.9	3.35	41.1	107.6	18.6	1.58	13.2	3.44	41.0	
			120	132.1	17.6	1.97	10.9	2.62	42.5	129.7	17.7	1.94	11.1	2.68	42.4	127.4	17.9	1.91	11.3	2.74	42.2	
4		60	73.8	20.1	0.98	16.7	6.03	40.9	71.1	20.3	0.95	17.0	6.26	40.7	68.5	20.5	0.93	17.3	6.49	40.5		
		80	93.3	19.4	1.31	14.9	4.34	41.9	90.7	19.5	1.28	15.2	4.47	41.7	88.1	19.7	1.25	15.4	4.61	41.6		
		100	112.8	18.6	1.64	13.0	3.33	42.9	110.3	18.8	1.61	13.3	3.41	42.8	107.8	18.9	1.58	13.5	3.50	42.6		
		120	132.3	17.9	1.97	11.2	2.66	43.9	129.9	18.0	1.94	11.4	2.72	43.8	127.5	18.1	1.91	11.6	2.78	43.7		
5		60	74.2	20.6	0.98	17.3	6.18	42.9	71.4	20.8	0.95	17.6	6.43	42.7	68.7	21.1	0.93	17.9	6.68	42.6		
		80	93.6	19.8	1.31	15.3	4.44	43.7	91.0	20.0	1.28	15.6	4.58	43.6	88.3	20.1	1.25	15.9	4.72	43.5		
		100	113.1	19.0	1.64	13.4	3.39	44.5	110.5	19.1	1.61	13.6	3.48	44.4	107.9	19.2	1.58	13.8	3.57	44.3		
		120	132.5	18.2	1.97	11.5	2.70	45.3	130.0	18.3	1.94	11.6	2.76	45.2	127.5	18.3	1.91	11.8	2.82	45.1		
70	3	60	76.4	23.9	0.98	20.6	7.15	55.9	73.2	24.2	0.95	20.9	7.46	55.6	70.1	24.4	0.92	21.3	7.77	55.4		
		80	95.8	22.9	1.31	18.5	5.12	57.3	92.7	23.2	1.28	18.8	5.30	57.1	89.6	23.4	1.25	19.1	5.49	56.9		
		100	115.1	22.0	1.65	16.3	3.91	58.8	112.2	22.2	1.61	16.7	4.03	58.6	109.2	22.3	1.57	17.0	4.16	58.3		
		120	134.4	21.0	1.98	14.2	3.11	60.2	131.6	21.2	1.94	14.5	3.20	60.0	128.8	21.3	1.90	14.8	3.28	59.8		
	4	60	76.9	24.6	0.98	21.2	7.34	58.4	73.6	24.8	0.95	21.6	7.66	58.2	70.4	25.1	0.92	22.0	7.99	58.0		
		80	96.2	23.5	1.31	19.0	5.24	59.6	93.0	23.7	1.28	19.3	5.43	59.4	89.9	23.9	1.25	19.7	5.62	59.3		
		100	115.4	22.5	1.65	16.8	3.99	60.8	112.4	22.6	1.61	17.1	4.11	60.7	109.4	22.8	1.57	17.4	4.24	60.5		
		120	134.7	21.4	1.98	14.6	3.17	62.0	131.8	21.5	1.94	14.9	3.25	61.9	128.9	21.6	1.90	15.1	3.33	61.7		
	5	60	77.3	25.2	0.98	21.9	7.53	61.0	74.0	25.5	0.95	22.3	7.88	60.8	70.6	25.8	0.92	22.7	8.22	60.7		
		80	96.5	24.1	1.31	19.6	5.37	61.9	93.3	24.3	1.28	19.9	5.56	61.8	90.1	24.5	1.25	20.2	5.76	61.7		
		100	115.8	22.9	1.65	17.3	4.08	62.9	112.7	23.1	1.61	17.6	4.20	62.8	109.6	23.2	1.57	17.8	4.32	62.6		
		120	135.0	21.8	1.98	15.0	3.23	63.8	132.0	21.9	1.94	15.2	3.30	63.7	129.0	21.9	1.90	15.4	3.38	63.6		
90	3	60	79.2	28.0	0.98	24.7	8.37	73.1	79.3	28.2	0.95	24.9	8.69	72.9	79.5	28.3	0.92	25.2	9.01	72.7		
		80	98.2	26.5	1.31	22.0	5.93	74.9	98.4	26.7	1.27	22.4	6.16	74.6	98.5	27.0	1.24	22.7	6.39	74.4		
		100	Operation not recommended																			
	120																					
	4	60																				
		80																				
		100																				
	5	60																				
		80																				
		100																				
120																						

NSW025 - Performance Data

Cooling Capacity

Source		Load Flow-4 GPM							Load Flow-5.5 GPM							Load Flow-7 GPM						
EST °F	Flow GPM	ELT °F	LLT °F	TC MBTUH	Power kW	HR MBTUH	EER	LST °F	LLT °F	TC MBTUH	Power kW	HR MBTUH	EER	LST °F	LLT °F	TC MBTUH	Power kW	HR MBTUH	EER	LST °F		
30	4	50	36.6	25.9	0.96	29.2	27.0	45.0	39.3	26.7	0.96	30.0	27.8	45.5	41.9	27.5	0.96	30.8	28.6	45.9		
		70	55.5	28.0	0.96	31.3	29.2	46.1	58.5	28.6	0.96	31.8	29.7	46.4	61.4	29.1	0.96	32.3	30.3	46.7		
		90	74.5	30.2	0.96	33.4	31.4	47.2	77.7	30.4	0.96	33.7	31.7	47.4	81.0	30.6	0.96	33.9	31.9	47.5		
		110	93.4	32.3	0.96	35.6	33.6	48.3	96.9	32.3	0.96	35.5	33.6	48.3	100.5	32.2	0.96	35.5	33.5	48.3		
	5.5	50	36.9	25.4	0.93	28.6	27.3	41.6	39.5	26.2	0.93	29.3	28.1	41.9	42.1	26.9	0.93	30.1	28.9	42.3		
		70	56.0	27.1	0.93	30.3	29.2	42.4	58.9	27.6	0.93	30.7	29.7	42.6	61.7	28.1	0.93	31.2	30.2	42.8		
		90	75.2	28.8	0.93	31.9	31.0	43.1	78.3	29.0	0.93	32.2	31.3	43.2	81.4	29.2	0.93	32.4	31.5	43.3		
		110	94.3	30.5	0.93	33.6	32.9	43.8	97.7	30.4	0.93	33.6	32.9	43.8	101.0	30.4	0.93	33.6	32.9	43.8		
	7	50	37.2	24.9	0.90	28.0	27.7	38.2	39.7	25.6	0.90	28.7	28.4	38.4	42.3	26.3	0.90	29.4	29.2	38.7		
		70	56.5	26.1	0.90	29.2	29.1	38.6	59.3	26.6	0.90	29.7	29.7	38.7	62.0	27.1	0.90	30.1	30.2	38.9		
		90	75.9	27.4	0.89	30.4	30.6	39.0	78.8	27.6	0.89	30.6	30.9	39.0	81.8	27.8	0.89	30.9	31.2	39.1		
		110	95.3	28.6	0.89	31.6	32.1	39.3	98.4	28.6	0.89	31.6	32.1	39.3	101.6	28.6	0.89	31.6	32.1	39.3		
50	4	50	37.3	24.6	1.24	28.8	21.2	64.8	39.8	25.4	1.24	29.6	21.8	65.2	42.3	26.2	1.24	30.4	22.5	65.7		
		70	55.4	28.3	1.25	32.6	24.0	66.8	58.3	29.0	1.25	33.3	24.5	67.2	61.2	29.7	1.25	34.0	25.0	67.5		
		90	73.4	32.1	1.26	36.4	26.7	68.8	76.8	32.7	1.26	37.0	27.1	69.1	80.2	33.3	1.26	37.6	27.5	69.4		
		110	91.5	35.9	1.27	40.2	29.4	70.7	95.3	36.4	1.27	40.7	29.7	71.0	99.1	36.9	1.27	41.2	29.9	71.3		
	5.5	50	37.5	24.3	1.20	28.4	20.3	61.5	39.9	25.1	1.20	29.2	21.0	61.9	42.4	25.9	1.20	30.0	21.6	62.2		
		70	55.7	27.8	1.20	31.9	23.1	63.0	58.5	28.5	1.20	32.6	23.7	63.3	61.4	29.2	1.20	33.3	24.3	63.6		
		90	73.9	31.3	1.21	35.4	25.9	64.4	77.2	31.8	1.21	35.9	26.4	64.7	80.5	32.4	1.21	36.5	26.8	64.9		
		110	92.1	34.7	1.21	38.9	28.7	65.9	95.8	35.2	1.21	39.3	29.1	66.1	99.5	35.7	1.21	39.8	29.4	66.3		
	7	50	37.6	24.1	1.16	28.0	22.0	58.3	40.0	24.9	1.16	28.8	22.8	58.5	42.4	25.7	1.16	29.6	23.5	58.7		
		70	56.0	27.2	1.16	31.2	24.5	59.2	58.8	27.9	1.16	31.9	25.1	59.4	61.6	28.6	1.16	32.5	25.8	59.6		
		90	74.3	30.4	1.16	34.3	27.1	60.1	77.5	30.9	1.16	34.9	27.5	60.3	80.7	31.5	1.16	35.4	28.0	60.4		
		110	92.7	33.6	1.16	37.5	29.6	61.0	96.3	34.0	1.16	37.9	29.9	61.2	99.9	34.4	1.16	38.3	30.2	61.3		
70	4	50	38.0	23.2	1.51	28.4	15.4	84.6	40.4	24.0	1.52	29.2	15.8	85.0	42.7	24.8	1.52	30.0	16.3	85.5		
		70	55.2	28.6	1.53	33.9	18.7	87.5	58.1	29.5	1.54	34.8	19.2	87.9	61.0	30.4	1.54	35.7	19.7	88.4		
		90	72.4	34.1	1.55	39.4	22.0	90.3	75.9	35.0	1.56	40.3	22.5	90.8	79.4	36.0	1.56	41.3	23.1	91.3		
		110	Operation not recommended																			
	5.5	50	38.0	23.2	1.47	28.2	15.8	81.4	40.3	24.1	1.47	29.1	16.4	81.8	42.7	25.0	1.47	30.0	17.0	82.1		
		70	55.3	28.5	1.48	33.5	19.3	83.6	58.2	29.4	1.48	34.4	19.9	84.0	61.1	30.3	1.48	35.3	20.5	84.3		
		90	72.6	33.7	1.49	38.8	22.7	85.8	76.1	34.7	1.49	39.7	23.3	86.2	79.5	35.6	1.49	40.7	23.9	86.5		
		110	Operation not recommended																			
	7	50	38.0	23.2	1.42	28.0	16.3	78.3	40.3	24.2	1.42	29.0	17.1	78.5	42.6	25.1	1.41	29.9	17.8	78.8		
		70	55.4	28.3	1.42	33.1	19.9	79.8	58.3	29.2	1.42	34.1	20.6	80.0	61.1	30.1	1.41	35.0	21.3	80.3		
		90	72.8	33.4	1.42	38.2	23.5	81.3	76.2	34.3	1.42	39.1	24.2	81.5	79.6	35.2	1.42	40.0	24.8	81.8		
		110	90.2	38.5	1.42	43.3	27.1	82.8	94.2	39.4	1.42	44.2	27.7	83.0	98.2	40.2	1.42	45.0	28.3	83.3		
90	4	50	39.3	20.9	1.93	27.4	11.6	104.1	41.4	21.5	1.94	28.1	12.0	104.5	43.5	22.2	1.94	28.8	12.3	104.9		
		70	56.3	26.6	1.96	33.3	14.5	107.2	59.0	27.4	1.97	34.1	14.9	107.6	61.7	28.3	1.97	35.0	15.3	108.0		
		90	Operation not recommended																			
		110	Operation not recommended																			
	5.5	50	39.2	20.9	1.88	27.3	11.1	101.1	41.3	21.6	1.88	28.0	11.5	101.4	43.4	22.4	1.88	28.8	11.9	101.7		
		70	56.3	26.7	1.89	33.1	14.1	103.4	59.0	27.5	1.90	34.0	14.5	103.8	61.7	28.3	1.90	34.8	14.9	104.1		
		90	Operation not recommended																			
		110	Operation not recommended																			
	7	50	39.2	21.0	1.83	27.2	12.3	98.0	41.3	21.7	1.83	28.0	12.8	98.2	43.4	22.5	1.83	28.7	13.3	98.5		
		70	56.2	26.8	1.83	33.0	15.6	99.7	58.9	27.6	1.83	33.8	16.1	100.0	61.6	28.4	1.83	34.6	16.6	100.2		
		90	Operation not recommended																			
		110	Operation not recommended																			
110	4	50	40.5	18.5	2.35	26.5	7.9	123.7	42.3	19.1	2.36	27.1	8.1	124.0	44.2	19.6	2.36	27.7	8.3	124.3		
		70	57.3	24.6	2.39	32.7	10.3	126.9	59.8	25.4	2.40	33.5	10.6	127.3	62.3	26.2	2.40	34.4	10.9	127.7		
		90	Operation not recommended																			
		110	Operation not recommended																			
	5.5	50	40.4	18.6	2.30	26.4	8.1	120.7	42.3	19.2	2.30	27.0	8.3	120.9	44.2	19.8	2.30	27.6	8.6	121.2		
		70	57.2	24.9	2.31	32.8	10.8	123.3	59.7	25.6	2.32	33.5	11.1	123.6	62.2	26.4	2.32	34.3	11.4	123.9		
		90	Operation not recommended																			
		110	Operation not recommended																			
	7	50	40.4	18.7	2.24	26.3	8.3	117.8	42.2	19.3	2.24	26.9	8.6	117.9	44.1	19.9	2.24	27.5	8.9	118.1		
		70	57.0	25.2	2.24	32.8	11.3	119.7	59.6	25.9	2.24	33.5	11.6	119.9	62.2	26.6	2.24	34.2	11.9	120.1		
		90	Operation not recommended																			
		110	Operation not recommended																			

NSW025 - Performance Data cont.

Heating Capacity

Source		Load Flow-4 GPM							Load Flow-5.5 GPM							Load Flow-7 GPM						
EST °F	Flow GPM	ELT °F	LLT °F	HC MBTUH	Power kW	HE MBTUH	COP	LST °F	LLT °F	HC MBTUH	Power kW	HE MBTUH	COP	LST °F	LLT °F	HC MBTUH	Power kW	HE MBTUH	COP	LST °F		
25	5.5	60	Operation not recommended																			
		80	Operation not recommended																			
		100	Operation not recommended																			
		120	Operation not recommended																			
	7	60	71.0	21.4	1.28	17.0	4.90	20.0	68.1	21.5	1.26	17.2	5.02	19.9	66.4	21.6	1.23	17.4	5.15	19.9		
		80	90.6	20.5	1.70	14.7	3.54	20.7	87.7	20.7	1.67	14.9	3.62	20.6	86.1	20.8	1.65	15.1	3.70	20.5		
		100	110.1	19.7	2.12	12.4	2.72	21.3	107.4	19.8	2.09	12.7	2.77	21.3	105.9	19.9	2.06	12.9	2.83	21.2		
		120	129.7	18.8	2.54	10.1	2.17	22.0	127.1	19.0	2.51	10.4	2.21	21.9	125.6	19.1	2.48	10.6	2.26	21.9		
30	4	60	71.4	22.2	1.29	17.8	5.04	20.8	69.1	22.4	1.26	18.1	5.21	20.7	66.7	22.6	1.23	18.4	5.38	20.5		
		80	91.0	21.4	1.71	15.6	3.67	22.0	88.7	21.6	1.68	15.9	3.78	21.8	86.4	21.8	1.64	16.2	3.88	21.7		
		100	110.6	20.6	2.12	13.4	2.84	23.1	108.4	20.8	2.09	13.6	2.91	23.0	106.2	20.9	2.06	13.9	2.98	22.8		
		120	130.2	19.8	2.54	11.1	2.28	24.3	128.1	20.0	2.51	11.4	2.33	24.1	125.9	20.1	2.47	11.7	2.38	24.0		
	5.5	60	71.8	22.9	1.29	18.4	5.19	22.6	69.3	23.0	1.26	18.7	5.35	22.5	66.8	23.2	1.23	19.0	5.53	22.4		
		80	91.3	21.9	1.71	16.1	3.76	23.5	88.9	22.1	1.68	16.4	3.87	23.4	86.6	22.3	1.64	16.7	3.98	23.3		
		100	110.8	21.0	2.12	13.7	2.90	24.5	108.6	21.2	2.09	14.1	2.97	24.4	106.3	21.4	2.06	14.4	3.05	24.2		
		120	130.3	20.1	2.54	11.4	2.31	25.4	128.2	20.3	2.51	11.7	2.37	25.3	126.0	20.5	2.47	12.1	2.43	25.2		
	7	60	72.1	23.5	1.29	19.1	5.34	24.4	69.6	23.7	1.26	19.3	5.50	24.3	67.0	23.8	1.23	19.6	5.67	24.2		
		80	91.6	22.4	1.71	16.6	3.85	25.1	89.1	22.6	1.68	16.9	3.96	25.0	86.7	22.8	1.64	17.2	4.07	24.9		
		100	111.0	21.4	2.12	14.1	2.95	25.8	108.7	21.6	2.09	14.5	3.03	25.7	106.4	21.9	2.06	14.8	3.12	25.6		
		120	130.5	20.3	2.54	11.6	2.34	26.6	128.3	20.6	2.51	12.1	2.41	26.5	126.2	20.9	2.47	12.5	2.48	26.3		
	50	4	60	75.2	29.4	1.31	24.9	6.55	37.2	71.9	29.5	1.27	25.1	6.79	37.1	68.7	29.5	1.23	25.3	7.03	37.0	
			80	94.5	28.2	1.74	22.3	4.74	38.5	91.4	28.3	1.69	22.5	4.89	38.4	88.3	28.3	1.65	22.7	5.04	38.3	
			100	113.9	27.0	2.16	19.6	3.65	39.9	111.0	27.1	2.11	19.9	3.75	39.7	108.0	27.2	2.06	20.1	3.85	39.6	
			120	133.3	25.9	2.59	17.0	2.91	41.2	130.5	25.9	2.54	17.3	2.99	41.1	127.7	26.0	2.48	17.5	3.07	41.0	
5.5		60	75.7	30.4	1.31	25.9	6.79	39.6	72.3	30.4	1.27	26.1	7.02	39.5	69.0	30.5	1.23	26.3	7.25	39.5		
		80	95.0	29.1	1.74	23.2	4.90	40.7	91.8	29.1	1.69	23.4	5.04	40.6	88.6	29.2	1.65	23.6	5.19	40.6		
		100	114.3	27.7	2.16	20.4	3.76	41.8	111.3	27.8	2.11	20.6	3.86	41.7	108.2	27.9	2.06	20.9	3.96	41.6		
		120	133.6	26.4	2.59	17.6	2.99	42.9	130.7	26.5	2.54	17.9	3.06	42.8	127.8	26.6	2.48	18.2	3.15	42.7		
7		60	76.2	31.5	1.32	27.0	6.98	42.1	72.7	31.4	1.27	27.1	7.23	42.0	69.2	31.4	1.23	27.2	7.48	42.0		
		80	95.4	30.0	1.74	24.0	5.02	42.9	92.1	30.0	1.69	24.2	5.18	42.9	88.8	30.0	1.65	24.4	5.34	42.8		
		100	114.7	28.5	2.17	21.1	3.83	43.8	111.5	28.5	2.11	21.3	3.95	43.7	108.4	28.6	2.06	21.6	4.06	43.6		
		120	133.9	27.0	2.59	18.1	3.04	44.7	131.0	27.1	2.54	18.4	3.13	44.6	128.0	27.3	2.48	18.8	3.22	44.5		
70		4	60	78.9	36.6	1.33	32.1	8.06	53.5	74.8	36.5	1.28	32.1	8.37	53.4	70.7	36.4	1.23	32.2	8.67	53.4	
			80	98.1	35.0	1.77	29.0	5.81	55.0	94.2	35.0	1.71	29.1	6.00	55.0	90.3	34.9	1.65	29.3	6.20	54.9	
			100	117.3	33.5	2.20	25.9	4.45	56.6	113.5	33.4	2.14	26.1	4.59	56.5	109.8	33.4	2.07	26.3	4.73	56.4	
			120	136.4	31.9	2.64	22.9	3.54	58.2	132.9	31.9	2.57	23.1	3.65	58.1	129.4	31.9	2.49	23.4	3.75	57.9	
	5.5	60	79.6	38.0	1.34	33.4	8.34	56.6	75.3	37.9	1.28	33.5	8.65	56.6	71.1	37.7	1.23	33.5	8.98	56.6		
		80	98.7	36.3	1.77	30.2	6.00	57.9	94.7	36.2	1.71	30.3	6.19	57.9	90.6	36.1	1.65	30.4	6.40	57.8		
		100	117.8	34.5	2.21	27.0	4.58	59.2	114.0	34.5	2.14	27.2	4.72	59.1	110.1	34.4	2.07	27.3	4.87	59.0		
		120	136.9	32.8	2.64	23.7	3.63	60.5	133.3	32.8	2.57	24.0	3.74	60.4	129.6	32.8	2.49	24.3	3.85	60.3		
	7	60	80.3	39.4	1.34	34.8	8.61	59.7	75.9	39.2	1.29	34.8	8.95	59.7	71.5	39.0	1.23	34.8	9.29	59.7		
		80	99.3	37.5	1.77	31.4	6.19	60.7	95.1	37.3	1.71	31.5	6.40	60.7	91.0	37.2	1.65	31.6	6.61	60.7		
		100	118.3	35.5	2.21	28.0	4.72	61.8	114.4	35.5	2.14	28.2	4.86	61.7	110.4	35.4	2.07	28.3	5.01	61.7		
		120	137.3	33.6	2.64	24.6	3.73	62.8	133.6	33.6	2.57	24.8	3.84	62.7	129.9	33.6	2.49	25.1	3.95	62.6		
90	4	60	82.7	44.0	1.37	39.3	9.41	69.7	77.7	43.7	1.31	39.2	9.79	69.8	72.8	43.4	1.25	39.1	10.17	69.8		
		80	101.6	41.9	1.80	35.7	6.80	71.6	96.9	41.7	1.73	35.8	7.07	71.6	92.2	41.5	1.66	35.9	7.33	71.5		
		100	Operation not recommended																			
		120	Operation not recommended																			
	5.5	60	83.5	45.5	1.38	40.8	9.66	73.6	78.2	44.8	1.32	40.3	9.96	73.8	73.0	44.1	1.26	39.8	10.30	73.9		
		80	102.3	43.2	1.81	37.0	6.99	75.2	97.4	42.8	1.74	36.8	7.22	75.2	92.5	42.4	1.66	36.7	7.46	75.2		
		100	Operation not recommended																			
		120	Operation not recommended																			
	7	60	84.2	47.0	1.39	42.3	9.91	77.6	78.7	45.9	1.33	41.4	10.16	77.8	73.2	44.8	1.26	40.5	10.42	78.1		
		80	102.9	44.5	1.82	38.3	7.18	78.7	97.8	43.8	1.74	37.9	7.38	78.8	92.7	43.2	1.67	37.5	7.59	79.0		
		100	Operation not recommended																			
		120	Operation not recommended																			

NSW025 DHW - Performance Data cont.

Heating Only Capacity

Source		Load Flow-4 GPM							Load Flow-5.5 GPM					Load Flow-7 GPM							
EST °F	Flow GPM	ELT °F	LLT °F	HC MBTUH	Power kW	HE MBTUH	COP	LST °F	LLT °F	HC MBTUH	Power kW	HE MBTUH	COP	LST °F	LLT °F	HC MBTUH	Power kW	HE MBTUH	COP	LST °F	
25	5.5	60	Operation not recommended																		
		80																			
		100																			
		120																			
	7	60	71.1	21.6	1.40	16.8	4.52	20.0	68.1	21.7	1.39	17.0	4.59	20.0	66.4	21.8	1.37	17.1	4.66	20.0	
		80	90.8	20.9	1.84	14.6	3.33	20.7	87.9	21.1	1.79	14.9	3.44	20.6	86.2	21.2	1.74	15.2	3.56	20.5	
		100	110.4	20.3	2.29	12.5	2.60	21.3	107.6	20.4	2.20	12.9	2.72	21.2	106.0	20.5	2.11	13.3	2.85	21.1	
		120	130.1	19.6	2.73	10.3	2.10	22.0	127.4	19.8	2.61	10.9	2.72	21.8	125.9	19.9	2.48	11.4	2.35	21.6	
30	4	60	71.7	22.7	1.41	17.9	4.72	20.8	69.2	22.8	1.38	18.0	4.83	20.7	66.7	22.8	1.35	18.2	4.95	20.6	
		80	91.4	22.1	1.86	15.7	3.48	21.9	89.0	22.1	1.77	16.1	3.67	21.7	86.5	22.2	1.68	16.4	3.87	21.5	
		100	111.0	21.4	2.31	13.5	2.72	23.0	108.7	21.5	2.16	14.1	2.93	22.7	106.3	21.5	2.00	14.7	3.15	22.4	
		120	130.7	20.8	2.76	11.4	2.21	24.1	128.4	20.9	2.55	12.2	2.42	23.7	126.2	20.9	2.33	12.9	2.63	23.3	
	5.5	60	72.0	23.3	1.42	18.4	4.81	22.6	69.4	23.3	1.38	18.6	4.94	22.5	66.9	23.4	1.35	18.8	5.08	22.5	
		80	91.6	22.5	1.87	16.2	3.54	23.5	89.1	22.6	1.80	16.5	3.68	23.4	86.7	22.7	1.73	16.8	3.84	23.2	
		100	111.2	21.8	2.32	13.9	2.76	24.4	108.9	21.9	2.21	14.3	2.90	24.2	106.5	22.0	2.11	14.8	3.05	24.0	
		120	130.9	21.1	2.77	11.7	2.24	25.3	128.6	21.2	2.63	12.2	2.36	25.1	126.3	21.3	2.50	12.7	2.50	24.8	
	7	60	72.3	23.8	1.42	19.0	4.91	24.4	69.7	23.9	1.39	19.2	5.06	24.4	67.1	24.0	1.35	19.4	5.21	24.3	
		80	91.9	23.0	1.87	16.6	3.60	25.1	89.3	23.1	1.83	16.9	3.70	25.0	86.8	23.2	1.79	17.1	3.80	25.0	
		100	111.4	22.2	2.32	14.3	2.80	25.8	109.0	22.3	2.27	14.5	2.88	25.7	106.6	22.4	2.22	14.8	2.95	25.6	
		120	131.0	21.4	2.77	11.9	2.26	26.5	128.7	21.5	2.72	12.2	2.32	26.4	126.4	21.6	2.66	12.5	2.38	26.3	
	50	4	60	75.2	29.5	1.47	24.4	5.85	37.4	71.9	29.5	1.42	24.7	6.06	37.3	68.7	29.6	1.38	24.9	6.27	37.2
			80	94.6	28.3	1.92	21.7	4.28	38.8	91.5	28.4	1.84	22.1	4.48	38.6	88.4	28.5	1.77	22.4	4.68	38.4
			100	114.0	27.1	2.38	19.0	3.32	40.2	111.0	27.2	2.27	19.5	3.50	40.0	108.1	27.4	2.16	20.0	3.68	39.7
			120	133.4	25.9	2.84	16.2	2.66	41.6	130.5	26.1	2.69	16.9	2.83	41.3	127.7	26.3	2.55	17.6	2.99	40.9
5.5		60	75.6	30.3	1.47	25.3	6.03	39.8	72.3	30.4	1.43	25.5	6.25	39.8	69.0	30.5	1.38	25.7	6.48	39.7	
		80	95.0	29.0	1.93	22.4	4.41	41.0	91.8	29.1	1.86	22.8	4.58	40.9	88.6	29.2	1.80	23.1	4.77	40.7	
		100	114.3	27.7	2.38	19.6	3.41	42.1	111.3	27.9	2.30	20.0	3.55	41.9	108.3	28.0	2.21	20.5	3.71	41.8	
		120	133.6	26.4	2.84	16.7	2.72	43.3	130.8	26.6	2.74	17.3	2.85	43.0	127.9	26.8	2.63	17.8	2.99	42.8	
7		60	76.1	31.2	1.48	26.1	6.13	42.3	72.7	31.3	1.43	26.4	6.38	42.2	69.2	31.4	1.38	26.6	6.63	42.2	
		80	95.3	29.8	1.94	23.2	4.48	43.2	92.1	29.9	1.88	23.5	4.64	43.1	88.8	30.0	1.83	23.8	4.80	43.0	
		100	114.6	28.3	2.39	20.2	3.45	44.1	111.5	28.5	2.33	20.6	3.57	43.9	108.5	28.7	2.27	21.0	3.69	43.8	
		120	133.9	26.9	2.85	17.2	2.76	44.9	131.0	27.2	2.78	17.7	2.85	44.8	128.1	27.4	2.72	18.1	2.95	44.7	
70		4	60	78.7	36.2	1.52	31.0	6.98	54.0	74.7	36.3	1.46	31.3	7.29	53.9	70.7	36.3	1.40	31.5	7.60	53.8
			80	97.8	34.5	1.98	27.7	5.09	55.7	94.0	34.6	1.92	28.1	5.29	55.5	90.2	34.7	1.85	28.4	5.49	55.4
			100	116.9	32.7	2.45	24.4	3.92	57.4	113.3	33.0	2.38	24.8	4.07	57.2	109.8	33.2	2.31	25.3	4.21	57.0
			120	136.0	31.0	2.91	21.1	3.12	59.1	132.6	31.3	2.84	21.6	3.24	58.9	129.3	31.6	2.76	22.2	3.35	58.6
	5.5	60	79.3	37.4	1.53	32.2	7.16	57.1	75.2	37.5	1.47	32.4	7.48	57.0	71.0	37.5	1.41	32.7	7.82	56.9	
		80	98.3	35.5	1.99	28.7	5.22	58.5	94.4	35.7	1.93	29.1	5.43	58.3	90.5	35.8	1.86	29.5	5.64	58.2	
		100	117.3	33.6	2.45	25.2	4.01	59.9	113.7	33.9	2.38	25.7	4.16	59.7	110.0	34.1	2.31	26.2	4.32	59.5	
		120	136.3	31.7	2.92	21.8	3.19	61.3	132.9	32.1	2.84	22.4	3.31	61.0	129.5	32.4	2.77	23.0	3.43	60.8	
	7	60	79.9	38.6	1.54	33.3	7.34	60.2	75.6	38.7	1.48	33.6	7.69	60.1	71.4	38.7	1.41	33.9	8.04	60.0	
		80	98.8	36.5	2.00	29.7	5.35	61.2	94.8	36.7	1.93	30.1	5.57	61.1	90.9	36.9	1.86	30.5	5.80	61.0	
		100	117.8	34.5	2.46	26.1	4.11	62.3	114.0	34.8	2.39	26.6	4.27	62.2	110.3	35.0	2.32	27.1	4.43	62.0	
		120	136.7	32.4	2.92	22.4	3.25	63.4	133.2	32.8	2.85	23.1	3.38	63.2	129.8	33.2	2.77	23.7	3.51	63.0	
90	4	60	82.0	42.7	1.56	37.4	8.02	70.7	82.2	43.0	1.49	37.9	8.48	70.5	82.3	43.3	1.42	38.5	8.93	70.2	
		80	100.9	40.5	2.02	33.6	5.86	72.7	101.0	40.8	1.95	34.2	6.15	72.4	101.2	41.1	1.87	34.8	6.44	72.1	
		100	Operation not recommended																		
	120																				
	5.5	60																			
		80																			
		100																			
	7	60																			
		80																			
		100																			
	120																				

NSW040 - Performance Data

Cooling Capacity

Source		Load Flow-5 GPM							Load Flow-7.5 GPM							Load Flow-10 GPM						
EST °F	Flow GPM	ELT °F	LLT °F	TC MBTUH	Power kW	HR MBTUH	EER	LST °F	LLT °F	TC MBTUH	Power kW	HR MBTUH	EER	LST °F	LLT °F	TC MBTUH	Power kW	HR MBTUH	EER	LST °F		
30	5	50	34.0	38.7	1.38	43.4	28.0	47.9	37.8	39.8	1.39	44.5	28.7	48.4	41.6	40.9	1.39	45.6	29.4	48.8		
		70	54.5	37.5	1.27	41.8	29.4	47.2	58.3	38.0	1.25	42.3	30.4	47.4	62.0	38.6	1.23	42.8	31.4	47.6		
		90	75.1	36.2	1.17	40.2	31.1	46.6	78.8	36.2	1.12	40.0	32.6	46.5	82.5	36.2	1.06	39.9	34.1	46.4		
		110	95.6	35.0	1.06	38.6	33.0	45.9	99.3	34.5	0.98	37.8	35.3	45.6	103.0	33.9	0.90	37.0	37.7	45.2		
	7.5	50	34.5	37.7	1.32	42.2	28.6	43.2	38.2	38.6	1.33	43.1	29.1	43.5	41.9	39.4	1.33	43.9	29.6	43.8		
		70	55.1	36.2	1.23	40.4	29.6	42.6	58.7	36.7	1.21	40.8	30.3	42.8	62.3	37.1	1.19	41.2	31.2	42.9		
		90	75.7	34.7	1.13	38.6	30.7	42.1	79.3	34.8	1.09	38.5	31.9	42.1	82.8	34.9	1.05	38.5	33.1	42.0		
		110	96.3	33.2	1.04	36.7	32.1	41.6	99.8	32.9	0.98	36.2	33.7	41.4	103.3	32.6	0.92	35.7	35.6	41.2		
	10	50	34.9	36.7	1.26	41.0	29.1	38.5	38.5	37.3	1.27	41.6	29.5	38.6	42.2	37.9	1.27	42.2	29.8	38.7		
		70	55.6	34.9	1.18	38.9	29.7	38.0	59.1	35.3	1.17	39.3	30.3	38.1	62.6	35.7	1.16	39.6	30.9	38.2		
		90	76.3	33.2	1.09	36.9	30.3	37.6	79.7	33.3	1.07	37.0	31.2	37.6	83.1	33.5	1.04	37.1	32.1	37.6		
		110	97.1	31.4	1.01	34.8	31.1	37.2	100.3	31.4	0.97	34.7	32.4	37.1	103.5	31.3	0.93	34.5	33.7	37.1		
50	5	50	35.3	35.7	1.76	41.7	21.6	67.2	38.6	37.4	1.76	43.4	22.6	67.9	41.9	39.2	1.76	45.2	23.5	68.6		
		70	53.4	40.2	1.73	46.1	24.5	69.0	57.3	41.5	1.72	47.4	25.5	69.5	61.2	42.8	1.71	48.6	26.4	70.1		
		90	71.5	44.8	1.71	50.6	27.4	70.9	76.0	45.6	1.69	51.4	28.5	71.2	80.4	46.4	1.66	52.1	29.5	71.5		
		110	89.6	49.4	1.68	55.1	30.4	72.7	94.7	49.7	1.65	55.3	31.7	72.8	99.7	50.1	1.62	55.6	33.0	72.9		
	7.5	50	39.1	35.3	1.69	41.0	20.9	62.8	38.8	36.9	1.68	42.6	21.9	63.3	42.1	38.5	1.68	44.2	22.9	63.8		
		70	57.8	39.2	1.65	44.8	23.7	64.0	58.7	40.3	1.64	45.9	24.5	64.4	61.4	41.5	1.63	47.1	25.4	64.7		
		90	76.5	43.0	1.62	48.6	26.5	65.2	77.8	43.8	1.60	49.2	27.3	65.4	80.8	44.5	1.59	49.9	28.1	65.7		
		110	95.2	46.9	1.59	52.3	29.5	66.5	95.4	47.2	1.56	52.5	30.2	66.5	100.2	47.5	1.54	52.7	30.9	66.6		
	10	50	42.8	34.9	1.61	40.4	23.0	58.3	38.9	36.4	1.61	41.9	23.8	58.6	42.2	37.9	1.61	43.3	24.7	58.9		
		70	62.1	38.1	1.57	43.5	25.3	59.0	60.1	39.1	1.57	44.5	26.1	59.2	61.7	40.2	1.56	45.5	26.9	59.4		
		90	81.5	41.3	1.54	46.5	27.6	59.6	79.6	41.9	1.52	47.1	28.4	59.7	81.2	42.6	1.51	47.7	29.1	59.8		
		110	100.8	44.5	1.50	49.6	30.0	60.2	96.2	44.7	1.48	49.7	30.8	60.3	100.7	44.9	1.46	49.9	31.5	60.3		
70	5	50	36.6	32.6	2.14	39.9	15.2	86.5	39.4	35.0	2.14	42.3	16.4	87.4	42.3	37.4	2.13	44.7	17.6	88.4		
		70	52.3	43.0	2.19	50.5	19.6	90.8	56.3	45.0	2.20	52.5	20.5	91.6	60.3	47.0	2.20	54.5	21.4	92.5		
		90	68.0	53.3	2.25	61.0	23.7	95.2	73.2	55.0	2.26	62.7	24.4	95.8	78.3	56.6	2.26	64.3	25.0	96.5		
		110	Operation not recommended																			
	7.5	50	36.5	32.9	2.05	39.8	16.0	82.3	39.4	35.2	2.04	42.2	17.2	83.1	42.2	37.6	2.04	44.5	18.5	83.8		
		70	56.9	42.1	2.08	49.2	20.2	85.3	58.7	44.0	2.08	51.1	21.2	85.9	60.5	45.9	2.08	52.9	22.1	86.5		
		90	73.9	51.4	2.11	58.6	24.3	88.4	76.4	52.7	2.12	59.9	24.9	88.8	78.8	54.1	2.12	61.3	25.5	89.3		
		110	Operation not recommended																			
	10	50	36.4	33.1	1.96	39.8	16.9	78.2	39.3	35.5	1.95	42.1	18.2	78.7	42.2	37.8	1.94	44.4	19.5	79.2		
		70	61.5	41.2	1.97	48.0	20.9	79.9	61.1	43.0	1.96	49.7	21.9	80.2	60.8	44.7	1.96	51.4	22.8	80.6		
		90	79.8	49.4	1.98	56.1	24.9	81.6	79.6	50.5	1.98	57.2	25.5	81.8	79.4	51.6	1.97	58.3	26.1	82.0		
		110	86.3	57.5	1.99	64.3	28.9	83.3	92.1	58.0	1.99	64.8	29.1	83.4	97.9	58.5	1.99	65.3	29.4	83.5		
90	5	50	38.0	29.1	2.74	38.4	11.4	105.8	40.6	30.9	2.74	40.3	12.2	106.6	43.2	32.8	2.74	42.2	13.0	107.4		
		70	53.8	39.2	2.80	48.8	15.0	110.1	57.5	41.1	2.81	50.7	15.7	110.9	61.1	43.0	2.81	52.6	16.4	111.7		
		90	69.6	49.4	2.86	59.1	18.4	114.4	74.3	51.3	2.87	61.1	19.0	115.2	79.0	53.3	2.88	63.1	19.6	116.0		
		110	Operation not recommended																			
	7.5	50	41.0	29.2	2.65	38.3	11.0	101.8	40.6	31.1	2.64	40.1	11.8	102.4	43.2	33.0	2.64	42.0	12.5	103.0		
		70	57.9	38.9	2.68	48.1	14.5	104.9	59.6	40.8	2.68	49.9	15.2	105.5	61.2	42.7	2.68	51.8	15.9	106.1		
		90	74.9	48.6	2.71	57.9	17.9	108.0	77.0	50.5	2.71	59.7	18.6	108.6	79.2	52.3	2.71	61.6	19.3	109.2		
		110	Operation not recommended																			
	10	50	43.9	29.4	2.55	38.1	12.5	97.9	40.5	31.3	2.54	40.0	13.4	98.2	43.1	33.3	2.54	41.9	14.3	98.6		
		70	62.0	38.7	2.56	47.4	16.2	99.8	61.7	40.5	2.55	49.2	17.0	100.1	61.3	42.3	2.54	51.0	17.8	100.5		
		90	80.1	47.9	2.56	56.6	19.8	101.7	79.8	49.6	2.56	58.4	20.6	102.0	79.4	51.4	2.55	60.1	21.3	102.4		
		110	Operation not recommended																			
110	5	50	39.5	25.5	3.34	36.9	7.6	125.2	41.8	26.9	3.35	38.3	8.0	125.8	44.2	28.2	3.35	39.6	8.4	126.3		
		70	55.4	35.5	3.41	47.1	10.4	129.4	58.7	37.3	3.42	48.9	10.9	130.2	61.9	39.1	3.42	50.8	11.4	130.9		
		90	Operation not recommended																			
		110	Operation not recommended																			
	7.5	50	39.4	25.6	3.24	36.7	7.9	121.4	41.8	27.0	3.24	38.1	8.3	121.8	44.1	28.5	3.24	39.5	8.8	122.2		
		70	59.0	35.8	3.28	46.9	10.9	124.5	60.4	37.6	3.28	48.8	11.5	125.1	61.9	39.5	3.28	50.7	12.1	125.7		
		90	Operation not recommended																			
		110	Operation not recommended																			
	10	50	39.4	25.7	3.14	36.4	8.2	117.5	41.7	27.2	3.14	37.9	8.7	117.8	44.1	28.7	3.13	39.4	9.2	118.1		
		70	62.6	36.1	3.14	46.8	11.5	119.6	62.2	38.0	3.14	48.7	12.1	120.0	61.8	39.9	3.13	50.6	12.8	120.4		
		90	Operation not recommended																			
		110	Operation not recommended																			

NSW040 - Performance Data cont.

Heating Capacity

Source		Load Flow-5 GPM							Load Flow-7.5 GPM							Load Flow-10 GPM						
EST °F	Flow GPM	ELT °F	LLT °F	HC MBTUH	Power kW	HE MBTUH	COP	LST °F	LLT °F	HC MBTUH	Power kW	HE MBTUH	COP	LST °F	LLT °F	HC MBTUH	Power kW	HE MBTUH	COP	LST °F		
25	7.5	60	Operation not recommended																			
		80	Operation not recommended																			
		100	Operation not recommended																			
		120	Operation not recommended																			
	10	60	72.2	29.7	1.83	23.5	4.76	20.2	68.2	29.7	1.78	23.6	4.89	20.1	66.1	29.6	1.72	23.7	5.04	20.1		
80		91.9	28.8	2.42	20.6	3.50	20.8	87.9	28.8	2.36	20.7	3.58	20.7	85.9	28.7	2.29	20.9	3.67	20.7			
100		111.5	28.0	3.00	17.7	2.73	21.3	107.7	27.9	2.94	17.9	2.78	21.3	105.7	27.8	2.87	18.0	2.84	21.3			
120		131.2	27.1	3.59	14.8	2.21	21.9	127.4	27.0	3.52	15.0	2.25	21.9	125.5	26.9	3.44	15.2	2.29	21.9			
30	5	60	72.7	30.9	1.84	24.6	4.92	19.8	69.5	30.8	1.79	24.7	5.06	19.8	66.3	30.7	1.73	24.8	5.20	19.8		
		80	92.4	30.0	2.42	21.8	3.64	21.0	89.3	30.0	2.36	21.9	3.73	21.0	86.2	29.9	2.30	22.0	3.81	20.9		
		100	112.0	29.2	2.99	19.0	2.85	22.2	109.0	29.1	2.93	19.1	2.91	22.1	106.0	29.0	2.86	19.3	2.97	22.1		
		120	131.7	28.3	3.57	16.1	2.32	23.4	128.7	28.3	3.50	16.3	2.37	23.3	125.8	28.2	3.43	16.5	2.41	23.2		
	7.5	60	73.3	32.3	1.84	26.0	5.14	22.1	70.0	32.2	1.78	26.1	5.29	22.1	66.6	32.2	1.73	26.3	5.46	22.0		
		80	92.8	31.0	2.43	22.7	3.74	23.1	89.6	31.0	2.36	23.0	3.85	23.0	86.4	31.1	2.29	23.2	3.97	22.9		
		100	112.3	29.8	3.02	19.5	2.90	24.0	109.2	29.9	2.94	19.9	2.98	23.9	106.2	30.0	2.86	20.2	3.07	23.9		
		120	131.8	28.6	3.61	16.3	2.32	25.0	128.9	28.7	3.52	16.7	2.39	24.9	125.9	28.9	3.43	17.1	2.46	24.8		
	10	60	73.9	33.6	1.84	27.3	5.35	24.4	70.4	33.6	1.78	27.5	5.54	24.3	66.9	33.6	1.72	27.7	5.72	24.3		
		80	93.2	32.0	2.44	23.7	3.85	25.1	89.9	32.1	2.37	24.1	3.99	25.0	86.6	32.2	2.29	24.4	4.12	25.0		
		100	112.6	30.5	3.04	20.1	2.94	25.9	109.5	30.7	2.95	20.6	3.05	25.8	106.4	30.9	2.86	21.1	3.16	25.6		
		120	131.9	28.9	3.64	16.5	2.33	26.6	129.0	29.2	3.54	17.1	2.42	26.5	126.1	29.5	3.43	17.8	2.52	26.3		
50	5	60	76.9	41.1	1.88	34.7	6.37	35.7	72.7	40.8	1.81	34.7	6.61	35.7	68.4	40.6	1.74	34.6	6.84	35.7		
		80	96.3	39.5	2.47	31.1	4.67	37.2	92.2	39.3	2.39	31.1	4.82	37.2	88.1	39.1	2.30	31.2	4.97	37.1		
		100	115.6	37.9	3.06	27.4	3.61	38.7	111.7	37.7	2.96	27.6	3.72	38.6	107.8	37.6	2.87	27.8	3.84	38.5		
		120	134.9	36.3	3.65	23.8	2.90	40.2	131.2	36.2	3.54	24.1	2.99	40.1	127.5	36.2	3.44	24.4	3.08	39.9		
	7.5	60	77.7	43.0	1.86	36.6	6.77	38.9	73.2	42.7	1.80	36.5	6.95	38.9	68.7	42.3	1.74	36.4	7.15	38.9		
		80	96.9	41.1	2.46	32.7	4.89	40.1	92.7	40.9	2.38	32.7	5.03	40.0	88.4	40.7	2.30	32.8	5.18	40.0		
		100	116.1	39.1	3.06	28.7	3.75	41.3	112.1	39.1	2.97	29.0	3.86	41.2	108.0	39.0	2.87	29.2	3.98	41.1		
		120	135.4	37.2	3.66	24.7	2.98	42.4	131.5	37.3	3.55	25.2	3.08	42.3	127.7	37.4	3.44	25.6	3.19	42.2		
	10	60	78.5	44.9	1.84	38.6	7.14	42.0	73.8	44.5	1.79	38.4	7.29	42.1	69.1	44.1	1.74	38.2	7.43	42.1		
		80	97.6	42.6	2.45	34.3	5.08	42.9	93.1	42.5	2.38	34.3	5.23	42.9	88.7	42.3	2.30	34.4	5.37	42.9		
		100	116.7	40.4	3.07	30.0	3.85	43.8	112.5	40.4	2.97	30.3	3.99	43.8	108.3	40.4	2.87	30.6	4.13	43.7		
		120	135.8	38.2	3.68	25.6	3.03	44.7	131.9	38.4	3.56	26.3	3.16	44.6	128.0	38.6	3.44	26.9	3.29	44.5		
70	5	60	81.2	51.3	1.92	44.7	7.83	51.5	75.8	50.9	1.83	44.6	8.16	51.6	70.4	50.4	1.74	44.5	8.49	51.7		
		80	100.2	48.9	2.52	40.3	5.69	53.4	95.1	48.6	2.42	40.4	5.91	53.4	90.0	48.3	2.31	40.4	6.13	53.3		
		100	119.2	46.6	3.12	35.9	4.37	55.2	114.4	46.4	3.00	36.1	4.54	55.1	109.5	46.2	2.88	36.4	4.70	55.0		
		120	138.2	44.2	3.72	31.5	3.48	57.0	133.7	44.2	3.59	31.9	3.61	56.8	129.1	44.1	3.45	32.3	3.75	56.7		
	7.5	60	82.1	53.7	1.88	47.3	8.37	55.6	76.5	53.1	1.81	46.9	8.58	55.7	70.8	52.5	1.75	46.5	8.82	55.8		
		80	101.1	51.1	2.49	42.6	6.00	57.1	95.7	50.7	2.40	42.5	6.18	57.1	90.4	50.3	2.31	42.4	6.38	57.1		
		100	120.0	48.5	3.11	37.9	4.57	58.5	115.0	48.3	2.99	38.1	4.73	58.4	109.9	48.1	2.88	38.3	4.90	58.4		
		120	138.9	45.9	3.72	33.2	3.61	59.9	134.2	45.9	3.58	33.6	3.75	59.8	129.5	45.9	3.45	34.1	3.90	59.6		
	10	60	83.1	56.1	1.84	49.8	8.93	59.7	77.2	55.4	1.80	49.2	9.04	59.9	71.3	54.6	1.75	48.6	9.14	60.0		
		80	102.0	53.2	2.47	44.8	6.32	60.8	96.4	52.8	2.39	44.6	6.47	60.8	90.8	52.3	2.31	44.4	6.62	60.8		
		100	120.8	50.4	3.09	39.8	4.77	61.8	115.5	50.2	2.99	40.0	4.93	61.8	110.3	50.0	2.88	40.2	5.09	61.7		
		120	139.6	47.5	3.72	34.8	3.74	62.8	134.7	47.6	3.58	35.4	3.90	62.7	129.8	47.7	3.44	36.0	4.06	62.6		
90	5	60	85.4	61.5	1.99	54.7	9.05	67.4	78.5	59.0	1.88	52.5	9.20	68.3	71.6	56.4	1.77	50.4	9.34	69.2		
		80	104.5	59.4	2.56	50.7	6.79	69.1	97.8	56.7	2.44	48.3	6.80	70.1	91.1	53.9	2.32	46.0	6.80	71.0		
		100	Operation not recommended																			
	7.5	60	86.2	63.7	2.01	56.8	9.30	72.6	79.0	60.4	1.89	53.9	9.37	73.5	71.8	57.1	1.77	51.0	9.44	74.3		
		80	105.5	61.9	2.58	53.1	7.03	73.8	98.4	58.3	2.45	49.9	6.97	74.7	91.3	54.7	2.33	46.8	6.90	75.6		
		100	124.8	60.1	3.15	49.3	5.59	75.0	117.8	56.2	3.01	45.9	5.47	76.0	110.8	52.4	2.88	42.6	5.33	76.9		
		120	Operation not recommended																			
	10	60	87.1	65.8	2.02	58.9	9.54	77.9	79.5	61.8	1.90	55.3	9.55	78.6	71.9	57.7	1.77	51.7	9.55	79.3		
		80	106.5	64.3	2.59	55.4	7.27	78.6	99.0	59.9	2.46	51.5	7.13	79.4	91.5	55.6	2.33	47.6	7.00	80.2		
		100	125.9	62.7	3.16	51.9	5.82	79.3	118.4	58.1	3.02	47.8	5.62	80.2	111.0	53.4	2.88	43.6	5.43	81.0		
		120	Operation not recommended																			

NSW050 - Performance Data

Cooling Capacity

Source		Load Flow-8 GPM							Load Flow-11.5 GPM							Load Flow-15 GPM						
EST °F	Flow GPM	ELT °F	LLT °F	TC MBTUH	Power kW	HR MBTUH	EER	LST °F	LLT °F	TC MBTUH	Power kW	HR MBTUH	EER	LST °F	LLT °F	TC MBTUH	Power kW	HR MBTUH	EER	LST °F		
30	8	50	35.8	55.2	1.98	61.9	27.9	46.0	38.8	57.0	2.00	63.8	28.6	46.4	41.9	58.8	2.01	65.7	29.3	46.9		
		70	54.6	59.8	2.01	66.6	29.8	47.2	58.0	61.0	2.02	67.8	30.3	47.5	61.5	62.2	2.02	69.1	30.7	47.8		
		90	73.4	64.3	2.03	71.3	31.6	48.4	77.2	64.9	2.04	71.9	31.9	48.5	81.0	65.5	2.04	72.5	32.2	48.7		
		110	92.2	68.9	2.06	75.9	33.4	49.6	96.4	68.9	2.06	75.9	33.5	49.6	100.5	68.9	2.05	75.9	33.6	49.6		
	11.5	50	35.9	54.6	1.90	61.1	28.8	42.1	39.0	56.3	1.92	62.8	29.3	42.5	42.0	57.9	1.94	64.5	29.8	42.8		
		70	55.0	58.1	1.92	64.6	30.3	42.9	58.4	59.1	1.93	65.7	30.7	43.1	61.7	60.2	1.94	66.9	31.0	43.3		
		90	74.2	61.5	1.93	68.1	31.8	43.6	77.8	62.0	1.94	68.6	32.0	43.8	81.4	62.6	1.94	69.2	32.3	43.9		
		110	93.3	64.9	1.95	71.6	33.3	44.4	97.2	64.9	1.95	71.5	33.4	44.4	101.1	64.9	1.94	71.5	33.5	44.4		
	15	50	36.1	54.1	1.82	60.3	29.7	38.3	39.1	55.6	1.85	61.8	30.1	38.5	42.2	57.0	1.87	63.4	30.5	38.7		
		70	55.5	56.4	1.83	62.6	30.9	38.6	58.7	57.3	1.84	63.6	31.1	38.7	62.0	58.3	1.86	64.6	31.4	38.9		
		90	74.9	58.6	1.83	64.9	32.0	38.9	78.3	59.1	1.84	65.4	32.2	39.0	81.8	59.6	1.84	65.9	32.3	39.1		
		110	94.3	60.9	1.84	67.2	33.1	39.2	98.0	60.9	1.84	67.2	33.2	39.2	101.6	60.9	1.83	67.1	33.3	39.2		
50	8	50	36.7	51.5	2.53	60.2	21.7	65.5	39.5	53.5	2.53	62.2	22.4	66.0	42.4	55.5	2.54	64.2	23.1	66.5		
		70	54.6	59.9	2.58	68.7	24.4	67.7	57.9	61.5	2.59	70.4	24.9	68.1	61.3	63.1	2.60	72.0	25.5	68.5		
		90	72.4	68.3	2.64	77.3	26.9	69.9	76.3	69.5	2.65	78.5	27.3	70.2	80.3	70.7	2.65	79.8	27.7	70.6		
		110	90.2	76.7	2.70	85.9	29.4	72.1	94.7	77.5	2.71	86.7	29.6	72.4	99.2	78.3	2.71	87.5	29.8	72.6		
	11.5	50	39.8	51.6	2.43	59.9	21.3	61.9	39.6	53.4	2.44	61.7	21.9	62.2	42.4	55.2	2.45	63.6	22.5	62.6		
		70	58.3	58.9	2.47	67.4	23.9	63.4	58.2	60.3	2.48	68.8	24.4	63.7	61.5	61.7	2.48	70.2	24.9	64.0		
		90	76.8	66.3	2.51	74.8	26.4	64.9	76.8	67.3	2.51	75.8	26.8	65.1	80.6	68.3	2.52	76.9	27.1	65.4		
		110	95.3	73.6	2.55	82.3	28.9	66.5	95.4	74.2	2.55	82.9	29.1	66.6	99.7	74.8	2.55	83.5	29.3	66.7		
	15	50	42.9	51.7	2.33	59.7	23.5	58.2	39.6	53.3	2.35	61.3	24.0	58.4	42.5	54.9	2.36	63.0	24.5	58.7		
		70	62.0	58.0	2.35	66.0	25.8	59.1	58.4	59.2	2.36	67.2	26.2	59.2	61.7	60.4	2.37	68.5	26.5	59.4		
		90	81.2	64.2	2.37	72.3	28.0	59.9	77.2	65.0	2.38	73.1	28.2	60.1	80.9	65.9	2.38	74.0	28.5	60.2		
		110	100.3	70.5	2.39	78.6	30.2	60.8	96.0	70.9	2.39	79.1	30.3	60.9	100.2	71.4	2.40	79.5	30.5	60.9		
70	8	50	37.7	47.9	3.07	58.4	15.6	85.0	40.2	50.1	3.07	60.5	16.3	85.6	42.8	52.2	3.07	62.7	17.0	86.2		
		70	54.5	60.1	3.16	70.9	19.0	88.3	57.9	62.1	3.17	72.9	19.6	88.8	61.2	64.0	3.17	74.9	20.2	89.3		
		90	71.4	72.3	3.25	83.4	22.2	91.5	75.5	74.1	3.26	85.2	22.7	92.0	79.6	75.9	3.27	87.0	23.2	92.4		
		110	Operation not recommended																			
	11.5	50	37.5	48.6	2.96	58.7	16.4	81.6	40.1	50.6	2.96	60.6	17.1	82.0	42.8	52.5	2.96	62.6	17.7	82.4		
		70	54.6	59.8	3.02	70.1	19.8	83.9	57.9	61.5	3.02	71.8	20.4	84.3	61.3	63.3	3.03	73.6	20.9	84.6		
		90	71.7	71.0	3.08	81.5	23.1	86.2	75.8	72.5	3.09	83.1	23.5	86.5	79.8	74.0	3.10	84.6	23.9	86.9		
		110	Operation not recommended																			
	15	50	37.3	49.3	2.84	59.0	17.4	78.1	40.0	51.1	2.85	60.8	17.9	78.4	42.7	52.8	2.85	62.5	18.5	78.6		
		70	54.7	59.5	2.87	69.3	20.7	79.5	58.0	61.0	2.88	70.8	21.2	79.7	61.4	62.5	2.89	72.3	21.6	79.9		
		90	72.0	69.8	2.91	79.7	24.0	81.0	76.1	71.0	2.92	80.9	24.3	81.1	80.1	72.1	2.92	82.1	24.7	81.3		
		110	89.4	80.0	2.94	90.0	27.2	82.4	94.1	80.9	2.95	91.0	27.4	82.5	98.8	81.8	2.96	91.9	27.6	82.6		
90	8	50	38.9	43.0	3.93	56.4	11.8	104.5	41.3	44.7	3.94	58.1	12.2	105.0	43.6	46.4	3.95	59.9	12.7	105.4		
		70	56.0	54.5	4.02	68.2	14.5	107.6	59.0	56.2	4.04	70.0	14.9	108.0	62.0	58.0	4.05	71.8	15.4	108.5		
		90	73.0	66.0	4.12	80.0	17.1	110.6	76.7	67.8	4.13	81.9	17.5	111.1	80.4	69.5	4.15	83.7	17.9	111.6		
		110	Operation not recommended																			
	11.5	50	38.8	43.6	3.81	56.6	11.5	101.2	41.2	45.2	3.81	58.2	11.8	101.5	43.6	46.8	3.82	59.8	12.2	101.8		
		70	55.9	54.7	3.87	67.9	14.1	103.4	59.0	56.3	3.88	69.6	14.5	103.8	62.0	57.9	3.89	71.2	14.9	104.1		
		90	73.0	65.9	3.93	79.3	16.8	105.7	76.8	67.5	3.95	81.0	17.1	106.1	80.5	69.1	3.96	82.7	17.4	106.4		
		110	Operation not recommended																			
	15	50	38.6	44.2	3.68	56.8	13.0	97.8	41.1	45.7	3.69	58.2	13.4	98.0	43.5	47.1	3.69	59.7	13.8	98.2		
		70	55.8	55.0	3.72	67.7	15.9	99.3	58.9	56.5	3.72	69.2	16.3	99.5	62.0	57.9	3.73	70.7	16.7	99.7		
		90	73.0	65.8	3.75	78.6	18.7	100.8	76.8	67.3	3.76	80.1	19.1	101.0	80.6	68.7	3.77	81.6	19.4	101.2		
		110	Operation not recommended																			
110	8	50	40.2	38.0	4.79	54.3	7.9	124.0	42.3	39.3	4.81	55.7	8.2	124.4	44.4	40.6	4.82	57.1	8.4	124.7		
		70	57.4	48.8	4.89	65.5	10.0	126.9	60.1	50.4	4.91	67.1	10.3	127.3	62.9	51.9	4.93	68.7	10.5	127.7		
		90	Operation not recommended																			
		110	Operation not recommended																			
	11.5	50	40.1	38.6	4.66	54.4	8.3	120.8	42.2	39.8	4.67	55.7	8.5	121.0	44.4	41.0	4.68	57.0	8.8	121.3		
		70	57.2	49.7	4.72	65.8	10.5	123.0	60.0	51.2	4.74	67.3	10.8	123.3	62.8	52.6	4.75	68.9	11.1	123.6		
		90	Operation not recommended																			
		110	Operation not recommended																			
	15	50	39.9	39.1	4.52	54.5	8.7	117.5	42.1	40.3	4.53	55.7	8.9	117.7	44.3	41.4	4.53	56.9	9.1	117.8		
		70	57.0	50.5	4.56	66.1	11.1	119.1	59.8	51.9	4.57	67.5	11.4	119.3	62.7	53.4	4.58	69.0	11.7	119.5		
		90	Operation not recommended																			
		110	Operation not recommended																			

NSW050 - Performance Data cont.

Heating Capacity

Source		Load Flow-8 GPM							Load Flow-11.5 GPM							Load Flow-15 GPM						
EST °F	Flow GPM	ELT °F	LLT °F	HC MBTUH	Power kW	HE MBTUH	COP	LST °F	LLT °F	HC MBTUH	Power kW	HE MBTUH	COP	LST °F	LLT °F	HC MBTUH	Power kW	HE MBTUH	COP	LST °F		
25	11.5	60	Operation not recommended																			
		80	Operation not recommended																			
		100	Operation not recommended																			
		120	Operation not recommended																			
	15	60	71.3	43.9	2.50	35.4	5.15	20.1	67.9	44.0	2.50	35.4	5.16	20.1	66.0	44.0	2.49	35.5	5.18	20.1		
80		91.0	42.6	3.41	31.0	3.66	20.7	87.6	42.6	3.37	31.1	3.71	20.7	85.9	42.6	3.33	31.3	3.75	20.7			
100		110.6	41.3	4.32	26.6	2.80	21.3	107.4	41.3	4.25	26.8	2.85	21.3	105.7	41.3	4.17	27.0	2.90	21.3			
120		130.3	40.0	5.23	22.2	2.24	22.0	127.2	40.0	5.12	22.5	2.29	21.9	125.5	39.9	5.01	22.8	2.33	21.9			
30	8	60	71.8	45.7	2.36	37.6	5.67	20.3	69.0	45.8	2.43	37.5	5.53	20.3	66.3	45.8	2.49	37.3	5.39	20.4		
		80	91.4	44.4	3.31	33.1	3.92	21.5	88.8	44.4	3.33	33.0	3.91	21.5	86.1	44.4	3.34	33.0	3.89	21.5		
		100	111.1	43.0	4.27	28.5	2.96	22.7	108.5	43.0	4.23	28.6	2.98	22.6	105.9	43.0	4.19	28.7	3.01	22.6		
		120	130.7	41.7	5.22	23.9	2.34	23.8	128.2	41.7	5.13	24.1	2.38	23.8	125.7	41.6	5.04	24.4	2.42	23.7		
	11.5	60	72.2	47.2	2.50	38.6	5.53	22.4	69.3	47.2	2.49	38.7	5.56	22.4	66.5	47.3	2.48	38.8	5.59	22.4		
		80	91.7	45.5	3.41	33.9	3.92	23.4	89.0	45.6	3.37	34.1	3.96	23.3	86.3	45.6	3.33	34.2	4.01	23.3		
		100	111.3	43.9	4.31	29.2	2.98	24.3	108.7	43.9	4.25	29.4	3.03	24.2	106.0	43.9	4.18	29.6	3.08	24.2		
		120	130.9	42.3	5.22	24.5	2.37	25.2	128.4	42.3	5.13	24.8	2.42	25.1	125.8	42.2	5.03	25.0	2.46	25.1		
	15	60	72.5	48.6	2.64	39.6	5.39	24.6	69.6	48.7	2.56	40.0	5.59	24.5	66.7	48.8	2.47	40.4	5.79	24.5		
		80	92.0	46.7	3.50	34.8	3.91	25.2	89.2	46.8	3.41	35.1	4.02	25.2	86.4	46.8	3.32	35.5	4.13	25.1		
		100	111.5	44.8	4.36	29.9	3.01	25.9	108.9	44.8	4.27	30.2	3.08	25.8	106.2	44.8	4.17	30.6	3.15	25.8		
		120	131.1	42.9	5.22	25.1	2.41	26.6	128.5	42.9	5.12	25.4	2.45	26.5	125.9	42.8	5.02	25.7	2.50	26.5		
50	8	60	75.1	58.8	2.56	50.0	6.65	37.1	71.6	58.6	2.54	50.0	6.72	37.1	68.0	58.5	2.52	49.9	6.80	37.1		
		80	94.5	56.3	3.47	44.4	4.71	38.5	91.1	56.2	3.42	44.6	4.80	38.5	87.7	56.2	3.36	44.7	4.88	38.5		
		100	113.9	53.9	4.39	38.9	3.58	40.0	110.6	53.8	4.30	39.2	3.66	39.9	107.4	53.8	4.21	39.4	3.74	39.8		
		120	133.2	51.4	5.30	33.3	2.83	41.4	130.2	51.4	5.18	33.7	2.91	41.3	127.1	51.5	5.06	34.2	2.98	41.2		
	11.5	60	75.7	61.0	2.64	52.0	6.78	39.8	72.0	60.8	2.58	52.0	6.91	39.9	68.3	60.5	2.51	51.9	7.06	39.9		
		80	95.0	58.1	3.53	46.1	4.83	41.0	91.5	57.9	3.44	46.2	4.93	41.0	87.9	57.8	3.36	46.3	5.04	41.0		
		100	114.2	55.2	4.41	40.2	3.67	42.1	110.9	55.1	4.31	40.4	3.75	42.1	107.6	55.0	4.21	40.6	3.83	42.0		
		120	133.5	52.4	5.30	34.3	2.89	43.3	130.3	52.3	5.18	34.6	2.96	43.2	127.2	52.3	5.06	35.0	3.03	43.1		
	15	60	76.3	63.3	2.72	54.0	6.79	42.6	72.4	62.9	2.61	54.0	7.03	42.6	68.6	62.5	2.51	53.9	7.27	42.6		
		80	95.4	59.9	3.58	47.7	4.89	43.4	91.8	59.6	3.47	47.8	5.03	43.4	88.2	59.4	3.36	47.9	5.17	43.4		
		100	114.6	56.6	4.44	41.5	3.72	44.3	111.2	56.4	4.32	41.7	3.82	44.3	107.7	56.2	4.20	41.9	3.91	44.2		
		120	133.7	53.3	5.30	35.2	2.94	45.2	130.5	53.2	5.18	35.5	3.01	45.1	127.3	53.1	5.05	35.8	3.07	45.1		
70	8	60	78.5	71.8	2.76	62.4	7.62	53.9	74.1	71.5	2.65	62.5	7.92	53.9	69.8	71.2	2.54	62.5	8.21	53.9		
		80	97.6	68.2	3.63	55.8	5.50	55.6	93.5	68.1	3.51	56.1	5.69	55.5	89.3	67.9	3.39	56.3	5.87	55.5		
		100	116.7	64.7	4.51	49.3	4.20	57.3	112.8	64.6	4.37	49.7	4.34	57.2	108.9	64.6	4.23	50.2	4.47	57.1		
		120	135.7	61.1	5.38	42.7	3.33	59.0	132.1	61.2	5.23	43.4	3.43	58.8	128.4	61.3	5.08	44.0	3.54	58.7		
	11.5	60	79.3	74.9	2.78	65.4	7.90	57.3	74.7	74.3	2.66	65.2	8.18	57.3	70.1	73.7	2.55	65.0	8.48	57.3		
		80	98.2	70.7	3.64	58.3	5.69	58.6	93.9	70.3	3.52	58.3	5.86	58.6	89.6	69.9	3.39	58.3	6.04	58.6		
		100	117.2	66.6	4.51	51.2	4.32	60.0	113.1	66.3	4.37	51.4	4.44	59.9	109.1	66.1	4.24	51.6	4.57	59.9		
		120	136.1	62.4	5.38	44.0	3.40	61.4	132.3	62.4	5.23	44.5	3.49	61.3	128.6	62.3	5.08	45.0	3.59	61.2		
	15	60	80.1	77.9	2.79	68.4	8.18	60.6	75.3	77.1	2.67	67.9	8.47	60.7	70.5	76.2	2.55	67.5	8.76	60.7		
		80	98.9	73.2	3.65	60.7	5.87	61.7	94.4	72.5	3.52	60.5	6.04	61.7	89.9	71.9	3.39	60.3	6.21	61.7		
		100	117.6	68.4	4.52	53.0	4.44	62.7	113.5	68.0	4.38	53.1	4.56	62.7	109.3	67.6	4.24	53.1	4.68	62.7		
		120	136.4	63.7	5.38	45.3	3.47	63.8	132.6	63.5	5.23	45.7	3.56	63.7	128.7	63.3	5.08	46.0	3.65	63.7		
90	8	60	81.9	84.9	2.85	75.2	8.73	70.6	76.5	82.8	3.51	70.8	7.21	71.7	71.1	80.7	4.16	66.5	5.68	72.9		
		80	100.6	80.1	3.71	67.4	6.32	72.6	95.6	78.7	4.09	64.8	5.70	73.3	90.6	77.4	4.47	62.2	5.08	74.0		
		100	119.4	75.2	4.58	59.6	4.82	74.6	114.8	74.7	4.68	58.7	4.68	74.9	110.2	74.1	4.77	57.8	4.55	75.1		
		120	Operation not recommended																			
	11.5	60	82.3	86.6	2.86	76.9	8.89	74.9	76.8	84.1	3.12	73.5	7.91	75.6	71.2	81.6	3.38	70.1	7.08	76.4		
		80	101.1	81.8	3.72	69.0	6.43	76.5	95.9	80.2	3.84	67.1	6.12	76.9	90.8	78.6	3.95	65.1	5.83	77.3		
		100	119.8	76.9	4.59	61.2	4.91	78.0	115.1	76.2	4.56	60.7	4.90	78.1	110.4	75.5	4.52	60.1	4.90	78.3		
		120	Operation not recommended																			
	15	60	82.8	88.3	2.86	78.5	9.05	79.2	77.0	85.4	2.73	76.1	9.19	79.5	71.3	82.5	2.59	73.7	9.33	79.9		
		80	101.5	83.4	3.73	70.7	6.55	80.3	96.2	81.6	3.58	69.3	6.68	80.5	91.0	79.7	3.43	68.0	6.81	80.7		
		100	120.2	78.6	4.61	62.8	5.00	81.4	115.4	77.7	4.44	62.6	5.14	81.4	110.6	76.9	4.26	62.3	5.28	81.4		
		120	Operation not recommended																			

NSW060 - Performance Data

Cooling Capacity

Source		Load Flow-9 GPM							Load Flow-13.5 GPM							Load Flow-18 GPM						
EST °F	Flow GPM	ELT °F	LLT °F	TC MBTUH	Power kW	HR MBTUH	EER	LST °F	LLT °F	TC MBTUH	Power kW	HR MBTUH	EER	LST °F	LLT °F	TC MBTUH	Power kW	HR MBTUH	EER	LST °F		
30	9	50	36.0	61.1	2.23	68.7	27.4	45.7	39.1	64.5	2.25	72.1	28.7	46.5	42.2	67.8	2.26	75.5	30.0	47.3		
		70	54.4	68.1	2.26	75.9	30.1	47.4	58.0	70.6	2.28	78.4	31.0	48.0	61.6	73.1	2.29	80.9	32.0	48.5		
		90	72.8	75.2	2.30	83.0	32.7	49.0	76.9	76.8	2.31	84.7	33.3	49.4	81.0	78.5	2.31	86.4	33.9	49.8		
		110	91.2	82.2	2.33	90.2	35.3	50.7	95.8	83.0	2.34	91.0	35.5	50.8	100.4	83.8	2.34	91.8	35.8	51.0		
	13.5	50	36.1	60.5	2.14	67.8	28.3	41.7	39.2	64.0	2.15	71.3	29.7	42.3	42.3	67.5	2.17	74.8	31.2	42.9		
		70	54.8	66.1	2.16	73.5	30.6	42.8	58.4	68.6	2.17	76.0	31.7	43.2	61.9	71.1	2.18	78.5	32.7	43.6		
		90	73.6	71.8	2.18	79.2	33.0	43.8	77.5	73.3	2.18	80.7	33.6	44.1	81.4	74.8	2.19	82.2	34.2	44.4		
		110	92.3	77.4	2.20	84.9	35.3	44.9	96.6	77.9	2.20	85.4	35.4	45.0	101.0	78.4	2.20	85.9	35.6	45.1		
	18	50	36.3	59.9	2.05	66.9	29.2	37.7	39.3	63.5	2.06	70.5	30.8	38.1	42.3	67.1	2.07	74.2	32.4	38.5		
		70	55.3	64.1	2.05	71.1	31.2	38.1	58.7	66.6	2.06	73.6	32.3	38.4	62.1	69.1	2.07	76.1	33.4	38.7		
		90	74.3	68.4	2.06	75.4	33.2	38.6	78.1	69.7	2.06	76.7	33.8	38.8	81.9	71.0	2.06	78.1	34.4	38.9		
		110	93.4	72.6	2.06	79.6	35.2	39.1	97.5	72.8	2.06	79.8	35.3	39.1	101.6	73.0	2.06	80.0	35.4	39.2		
50	9	50	36.8	57.4	2.86	67.2	21.4	65.4	39.8	60.2	2.87	70.0	22.4	66.0	42.8	63.0	2.88	72.8	23.3	66.7		
		70	54.3	68.3	2.93	78.3	24.6	67.9	58.0	70.6	2.94	80.7	25.3	68.5	61.6	72.9	2.95	83.0	26.0	69.0		
		90	71.8	79.3	3.00	89.5	27.6	70.5	76.2	81.1	3.01	91.3	28.1	70.9	80.5	82.8	3.02	93.2	28.6	71.3		
		110	89.3	90.2	3.07	100.7	30.5	73.1	94.4	91.5	3.08	102.0	30.8	73.4	99.4	92.8	3.10	103.3	31.1	73.7		
	13.5	50	36.9	57.3	2.75	66.6	20.9	61.5	39.8	60.2	2.75	69.6	21.9	62.0	42.8	63.1	2.76	72.5	22.9	62.5		
		70	54.7	66.9	2.79	76.4	24.0	63.2	58.2	69.2	2.80	78.8	24.7	63.6	61.8	71.5	2.81	81.1	25.5	64.0		
		90	72.5	76.6	2.83	86.2	27.0	65.0	76.7	78.2	2.84	87.9	27.5	65.3	80.8	79.9	2.85	89.7	28.0	65.6		
		110	90.3	86.2	2.88	96.0	30.0	66.8	95.1	87.3	2.89	97.1	30.2	67.0	99.9	88.3	2.90	98.2	30.5	67.2		
	18	50	36.9	57.2	2.63	66.1	23.1	57.6	39.8	60.2	2.64	69.2	24.3	57.9	42.8	63.2	2.64	72.2	25.4	58.3		
		70	55.0	65.5	2.65	74.5	25.9	58.5	58.5	67.8	2.66	76.9	26.8	58.8	62.0	70.1	2.66	79.2	27.6	59.1		
		90	73.1	73.9	2.67	83.0	28.7	59.5	77.1	75.4	2.68	84.6	29.2	59.7	81.2	77.0	2.68	86.2	29.8	59.9		
		110	91.2	82.2	2.69	91.4	31.5	60.5	95.8	83.1	2.70	92.2	31.7	60.6	100.4	83.9	2.71	93.1	31.9	60.7		
70	9	50	37.7	53.7	3.49	65.6	15.4	85.0	40.5	56.0	3.50	67.9	16.0	85.6	43.3	58.2	3.50	70.1	16.6	86.1		
		70	54.3	68.5	3.60	80.8	19.1	88.5	58.0	70.6	3.61	82.9	19.6	89.0	61.7	72.7	3.62	85.0	20.1	89.5		
		90	70.9	83.4	3.70	96.0	22.5	92.0	75.5	85.3	3.72	98.0	22.9	92.4	80.0	87.2	3.73	99.9	23.4	92.9		
		110	Operation not recommended																			
	13.5	50	37.6	54.1	3.35	65.5	16.1	81.3	40.4	56.4	3.35	67.8	16.8	81.7	43.3	58.8	3.36	70.2	17.5	82.1		
		70	54.5	67.7	3.42	79.4	19.8	83.7	58.1	69.8	3.43	81.5	20.4	84.1	61.8	71.9	3.44	83.6	20.9	84.5		
		90	71.4	81.4	3.49	93.3	23.3	86.2	75.8	83.2	3.50	95.2	23.7	86.5	80.3	85.1	3.52	97.1	24.2	86.8		
		110	Operation not recommended																			
	18	50	37.5	54.4	3.21	65.4	16.9	77.5	40.4	56.9	3.21	67.8	17.7	77.8	43.2	59.3	3.21	70.3	18.5	78.0		
		70	54.7	66.9	3.24	77.9	20.6	78.9	58.3	69.0	3.25	80.1	21.2	79.2	61.9	71.1	3.26	82.2	21.8	79.4		
		90	71.8	79.3	3.28	90.5	24.2	80.4	76.2	81.2	3.29	92.4	24.7	80.6	80.5	83.0	3.30	94.2	25.1	80.8		
		110	89.0	91.8	3.31	103.1	27.7	81.8	94.1	93.3	3.33	104.7	28.0	82.0	99.1	94.8	3.35	106.2	28.3	82.2		
90	9	50	39.1	47.6	4.48	62.8	11.5	104.4	41.6	49.5	4.48	64.7	11.9	104.8	44.1	51.4	4.49	66.7	12.4	105.3		
		70	55.8	61.8	4.58	77.4	14.5	107.7	59.2	63.7	4.59	79.4	14.9	108.2	62.5	65.6	4.61	81.4	15.3	108.6		
		90	72.6	76.1	4.68	92.0	17.3	111.1	76.7	78.0	4.70	94.0	17.7	111.5	80.8	79.9	4.73	96.1	18.0	112.0		
		110	Operation not recommended																			
	13.5	50	39.0	48.0	4.32	62.7	11.1	100.8	41.5	49.9	4.32	64.6	11.5	101.1	44.1	51.9	4.33	66.6	12.0	101.4		
		70	55.9	61.6	4.38	76.5	14.1	103.2	59.2	63.6	4.40	78.6	14.5	103.5	62.5	65.5	4.41	80.6	14.9	103.9		
		90	72.8	75.2	4.45	90.4	16.9	105.6	76.8	77.2	4.47	92.5	17.3	106.0	80.9	79.2	4.49	94.6	17.6	106.3		
		110	Operation not recommended																			
	18	50	38.9	48.4	4.16	62.5	12.6	97.2	41.5	50.4	4.16	64.5	13.1	97.4	44.0	52.4	4.16	66.5	13.7	97.6		
		70	55.9	61.4	4.19	75.7	15.7	98.7	59.2	63.4	4.20	77.7	16.2	98.9	62.5	65.5	4.21	79.8	16.7	99.1		
		90	73.0	74.4	4.22	88.8	18.8	100.2	77.0	76.5	4.24	90.9	19.3	100.4	81.0	78.6	4.25	93.1	19.7	100.7		
		110	Operation not recommended																			
110	9	50	40.5	41.4	5.46	60.0	7.6	123.8	42.7	43.0	5.47	61.6	7.9	124.1	44.9	44.5	5.48	63.2	8.1	124.5		
		70	57.4	55.1	5.55	74.0	9.9	127.0	60.3	56.8	5.58	75.9	10.2	127.4	63.3	58.6	5.61	77.7	10.4	127.8		
		90	Operation not recommended																			
		110	Operation not recommended																			
	13.5	50	40.4	41.9	5.29	59.9	7.9	120.3	42.6	43.4	5.29	61.5	8.2	120.6	44.9	45.0	5.30	63.0	8.5	120.8		
		70	57.3	55.5	5.35	73.7	10.4	122.7	60.3	57.3	5.36	75.6	10.7	123.0	63.2	59.2	5.38	77.5	11.0	123.3		
		90	Operation not recommended																			
		110	Operation not recommended																			
	18	50	40.3	42.3	5.11	59.7	8.3	116.8	42.6	43.9	5.11	61.3	8.6	117.0	44.8	45.4	5.11	62.8	8.9	117.2		
		70	57.2	55.9	5.14	73.4	10.9	118.4	60.2	57.8	5.15	75.4	11.2	118.6	63.2	59.8	5.16	77.4	11.6	118.9		
		90	Operation not recommended																			
		110	Operation not recommended																			

NSW060 - Performance Data cont.

Heating Capacity

Source		Load Flow-9 GPM							Load Flow-13.5 GPM							Load Flow-18 GPM						
EST °F	Flow GPM	ELT °F	LLT °F	HC MBTUH	Power kW	HE MBTUH	COP	LST °F	LLT °F	HC MBTUH	Power kW	HE MBTUH	COP	LST °F	LLT °F	HC MBTUH	Power kW	HE MBTUH	COP	LST °F		
25	13.5	60	Operation not recommended																			
		80	Operation not recommended																			
		100	Operation not recommended																			
		120	Operation not recommended																			
	18	60	71.1	48.3	2.93	38.3	4.83	20.6	67.4	48.6	2.86	38.8	4.98	20.6	65.6	48.9	2.79	39.4	5.14	20.5		
		80	90.8	47.3	3.93	33.9	3.53	21.1	87.3	47.6	3.85	34.4	3.62	21.1	85.5	47.8	3.76	35.0	3.72	21.0		
		100	110.6	46.3	4.93	29.5	2.75	21.6	107.1	46.5	4.83	30.0	2.82	21.6	105.4	46.8	4.74	30.6	2.89	21.5		
		120	130.4	45.3	5.93	25.1	2.24	22.1	126.9	45.5	5.82	25.6	2.29	22.1	125.2	45.7	5.71	26.2	2.35	22.0		
30	9	60	71.5	50.1	2.94	40.1	4.99	20.8	68.7	50.5	2.87	40.7	5.17	20.7	65.8	50.9	2.79	41.4	5.35	20.5		
		80	91.3	49.3	3.95	35.9	3.66	21.8	88.5	49.7	3.86	36.5	3.77	21.6	85.7	50.0	3.77	37.1	3.89	21.5		
		100	111.1	48.6	4.95	31.7	2.87	22.7	108.4	48.8	4.85	32.3	2.95	22.6	105.6	49.0	4.74	32.8	3.03	22.5		
		120	131.0	47.8	5.96	27.5	2.35	23.7	128.2	48.0	5.84	28.0	2.41	23.6	125.5	48.1	5.72	28.6	2.46	23.5		
	13.5	60	71.9	52.1	3.0	42.0	5.17	22.9	68.9	51.8	2.87	42.0	5.29	22.9	65.9	51.6	2.8	42.0	5.41	22.8		
		80	91.7	50.9	4.0	37.4	3.77	23.7	88.7	50.8	3.86	37.6	3.86	23.6	85.8	50.7	3.8	37.8	3.95	23.5		
		100	111.4	49.7	5.0	32.8	2.94	24.4	108.6	49.8	4.84	33.2	3.01	24.3	105.7	49.8	4.7	33.7	3.08	24.3		
		120	131.1	48.6	6.0	28.2	2.39	25.2	128.4	48.8	5.83	28.9	2.45	25.1	125.6	49.0	5.7	29.5	2.51	25.0		
	18	60	72.4	54.1	2.97	44.0	5.34	25.0	69.2	53.2	2.88	43.3	5.41	25.0	66.0	52.2	2.79	42.7	5.48	25.1		
		80	92.0	52.5	3.96	39.0	3.88	25.5	89.0	52.0	3.86	38.8	3.95	25.6	85.9	51.4	3.76	38.6	4.01	25.6		
		100	111.7	50.9	4.96	34.0	3.01	26.1	108.7	50.8	4.84	34.2	3.07	26.1	105.8	50.6	4.72	34.5	3.14	26.1		
		120	131.3	49.3	5.95	29.0	2.43	26.7	128.5	49.6	5.82	29.7	2.50	26.6	125.7	49.8	5.69	30.4	2.56	26.5		
	50	9	60	75.1	66.0	3.0	55.7	6.34	37.2	71.4	66.2	2.92	56.2	6.62	37.1	67.6	66.3	2.8	56.7	6.90	37.0	
			80	94.6	63.9	4.0	50.2	4.66	38.5	91.0	64.1	3.89	50.8	4.83	38.4	87.4	64.3	3.8	51.4	4.99	38.2	
			100	114.1	61.7	5.0	44.7	3.63	39.8	110.6	62.0	4.86	45.4	3.74	39.6	107.1	62.3	4.7	46.1	3.86	39.4	
			120	133.7	59.6	6.0	39.3	2.93	41.0	130.3	60.0	5.83	40.1	3.02	40.8	126.9	60.3	5.7	40.9	3.11	40.6	
13.5		60	75.8	68.8	3.1	58.4	6.61	40.1	71.8	68.5	2.93	58.5	6.84	40.1	67.8	68.2	2.8	58.5	7.09	40.0		
		80	95.2	66.2	4.0	52.5	4.81	41.1	91.4	66.1	3.90	52.8	4.96	41.0	87.6	66.1	3.8	53.2	5.13	41.0		
		100	114.6	63.7	5.0	46.6	3.72	42.1	111.0	63.8	4.87	47.2	3.84	42.0	107.3	64.0	4.7	47.8	3.96	41.9		
		120	134.0	61.1	6.0	40.6	2.98	43.1	130.5	61.5	5.85	41.5	3.08	42.9	127.1	61.9	5.7	42.4	3.18	42.8		
18		60	76.4	71.6	3.1	61.1	6.79	43.0	72.2	70.8	2.95	60.7	7.01	43.0	68.0	70.0	2.8	60.4	7.24	43.1		
		80	95.7	68.6	4.1	54.7	4.93	43.7	91.7	68.2	3.92	54.8	5.09	43.7	87.8	67.8	3.8	54.9	5.25	43.7		
		100	115.0	65.6	5.1	48.4	3.79	44.5	111.3	65.6	4.89	48.9	3.92	44.4	107.5	65.6	4.7	49.4	4.06	44.3		
		120	134.3	62.6	6.0	42.0	3.03	45.2	130.8	63.0	5.87	43.0	3.15	45.1	127.3	63.4	5.7	44.0	3.26	45.0		
70		9	60	78.8	81.9	3.12	71.3	7.69	53.7	74.1	81.8	2.98	71.6	8.07	53.6	69.4	81.7	2.83	72.0	8.46	53.5	
			80	98.0	78.4	4.06	64.5	5.65	55.2	93.5	78.5	3.92	65.1	5.88	55.1	89.0	78.6	3.78	65.7	6.10	54.9	
			100	117.2	74.9	5.01	57.8	4.38	56.8	112.9	75.2	4.87	58.6	4.54	56.6	108.7	75.6	4.72	59.4	4.69	56.4	
			120	136.4	71.4	5.95	51.1	3.52	58.3	132.3	72.0	5.81	52.1	3.63	58.1	128.3	72.5	5.67	53.1	3.75	57.8	
	13.5	60	79.6	85.5	3.1	74.8	7.97	57.4	74.6	85.1	3.00	74.9	8.33	57.3	69.7	84.8	2.8	75.0	8.73	57.3		
		80	98.7	81.6	4.1	67.5	5.81	58.6	94.0	81.5	3.95	68.0	6.04	58.5	89.3	81.4	3.8	68.5	6.29	58.4		
		100	117.8	77.6	5.1	60.3	4.48	59.8	113.4	77.8	4.91	61.1	4.65	59.6	108.9	78.1	4.7	61.9	4.83	59.5		
		120	136.9	73.7	6.0	53.0	3.57	61.0	132.7	74.2	5.86	54.2	3.71	60.8	128.6	74.8	5.7	55.4	3.86	60.6		
	18	60	80.4	89.1	3.17	78.3	8.24	61.0	75.2	88.5	3.02	78.2	8.62	61.0	70.1	87.8	2.86	78.0	8.99	61.1		
		80	99.4	84.7	4.16	70.5	5.97	61.9	94.5	84.5	3.98	70.9	6.23	61.9	89.6	84.2	3.80	71.2	6.49	61.8		
		100	118.4	80.3	5.14	62.7	4.57	62.8	113.8	80.5	4.95	63.6	4.77	62.7	109.2	80.6	4.75	64.4	4.98	62.6		
		120	137.4	75.9	6.13	55.0	3.63	63.7	133.1	76.5	5.91	56.3	3.80	63.6	128.8	77.0	5.69	57.6	3.96	63.4		
	90	9	60	82.4	97.7	3.26	86.6	8.78	70.2	76.5	95.2	3.09	84.7	9.04	70.6	70.6	92.7	2.92	82.7	9.30	71.0	
			80	101.4	93.2	4.25	78.7	6.42	72.0	95.9	91.9	4.06	78.0	6.65	72.1	90.4	90.5	3.86	77.4	6.87	72.3	
			100	Operation not recommended																		
		13.5	60	82.8	99.7	3.3	88.4	8.89	74.9	76.8	96.7	3.11	86.1	9.12	75.3	70.7	93.7	2.9	83.7	9.37	75.7	
80			101.8	95.3	4.3	80.6	6.52	76.3	96.2	93.5	4.08	79.6	6.72	76.4	90.5	91.8	3.9	78.6	6.94	76.6		
100			120.8	90.9	5.3	72.8	5.04	77.6	115.6	90.4	5.05	73.1	5.24	77.5	110.3	89.9	4.8	73.4	5.46	77.5		
18		60	83.3	101.6	3.31	90.3	8.99	79.7	77.1	98.2	3.13	87.5	9.22	80.0	70.8	94.7	2.94	84.7	9.44	80.3		
		80	102.3	97.3	4.31	82.6	6.61	80.5	96.5	95.2	4.10	81.2	6.81	80.7	90.7	93.1	3.89	79.8	7.00	80.9		
		100	121.3	93.0	5.31	74.9	5.13	81.4	115.9	92.2	5.08	74.9	5.33	81.4	110.5	91.4	4.85	74.9	5.53	81.4		
		120	Operation not recommended																			

NSW075 - Performance Data

Cooling Capacity

Source		Load Flow-10 GPM							Load Flow-14.5 GPM							Load Flow-19 GPM						
EST °F	Flow GPM	ELT °F	LLT °F	TC MBTUH	Power kW	HR MBTUH	EER	LST °F	LLT °F	TC MBTUH	Power kW	HR MBTUH	EER	LST °F	LLT °F	TC MBTUH	Power kW	HR MBTUH	EER	LST °F		
30	10	50	34.7	74.0	3.14	84.7	23.6	47.5	37.9	77.8	3.19	88.7	24.4	48.3	41.1	81.6	3.24	92.7	25.2	49.1		
		70	52.4	85.1	3.29	96.4	25.9	49.9	56.3	88.0	3.34	99.3	26.3	50.5	60.2	90.8	3.38	102.3	26.8	51.1		
		90	70.2	96.3	3.45	108.0	27.9	52.3	74.7	98.1	3.49	110.0	28.1	52.7	79.2	99.9	3.53	112.0	28.3	53.1		
		110	87.9	107.4	3.60	119.7	29.8	54.7	93.0	108.3	3.64	120.7	29.8	54.9	98.2	109.1	3.67	121.6	29.7	55.1		
	14.5	50	34.7	74.1	3.01	84.4	24.6	43.3	37.9	77.8	3.05	88.2	25.5	43.9	41.2	81.4	3.09	91.9	26.3	44.5		
		70	52.9	83.1	3.12	93.8	26.6	44.9	56.6	85.8	3.16	96.6	27.2	45.3	60.4	88.5	3.20	99.4	27.7	45.8		
		90	71.0	92.2	3.24	103.2	28.5	46.5	75.3	93.8	3.27	105.0	28.7	46.8	79.6	95.5	3.30	106.8	28.9	47.1		
		110	89.1	101.2	3.35	112.6	30.2	48.1	94.0	101.9	3.38	113.4	30.2	48.2	98.9	102.6	3.41	114.2	30.1	48.3		
	19	50	34.7	74.2	2.88	84.0	25.8	39.1	37.9	77.7	2.91	87.6	26.7	39.5	41.2	81.2	2.94	91.2	27.6	39.9		
		70	53.3	81.1	2.95	91.2	27.5	39.9	57.0	83.6	2.98	93.8	28.1	40.2	60.7	86.1	3.01	96.4	28.6	40.5		
		90	71.8	88.1	3.03	98.4	29.1	40.7	76.0	89.6	3.05	100.0	29.4	40.8	80.1	91.1	3.07	101.6	29.6	41.0		
		110	90.4	95.0	3.10	105.6	30.6	41.5	95.0	95.5	3.12	106.1	30.6	41.5	99.6	96.0	3.14	106.7	30.6	41.6		
50	10	50	35.8	68.9	3.94	82.3	18.5	67.0	38.8	72.3	3.99	85.9	19.2	67.7	41.8	75.6	4.03	89.4	19.8	68.4		
		70	52.9	83.0	4.16	97.2	21.0	70.0	56.6	85.8	4.21	100.2	21.4	70.6	60.4	88.6	4.26	103.1	21.8	71.3		
		90	70.0	97.0	4.38	112.0	23.2	73.1	74.5	99.3	4.44	114.5	23.4	73.6	79.0	101.6	4.49	116.9	23.6	74.1		
		110	87.1	111.1	4.60	126.8	25.2	76.1	92.3	112.9	4.66	128.8	25.2	76.5	97.6	114.6	4.72	130.7	25.3	77.0		
	14.5	50	35.7	69.3	3.78	82.2	18.3	62.9	38.7	72.6	3.82	85.6	19.0	63.5	41.8	75.9	3.86	89.0	19.7	64.0		
		70	53.2	81.7	3.95	95.2	20.7	65.1	56.8	84.4	3.99	98.0	21.1	65.5	60.5	87.1	4.04	100.9	21.6	66.0		
		90	70.6	94.1	4.12	108.2	22.9	67.2	75.0	96.3	4.17	110.5	23.1	67.6	79.3	98.4	4.22	112.7	23.3	67.9		
		110	88.0	106.6	4.29	121.2	24.9	69.3	93.1	108.1	4.34	122.9	24.9	69.6	98.1	109.6	4.40	124.6	24.9	69.9		
	19	50	35.6	69.7	3.63	82.0	20.3	58.9	38.7	72.9	3.66	85.4	21.1	59.3	41.7	76.2	3.69	88.7	21.8	59.6		
		70	53.4	80.5	3.74	93.2	22.5	60.1	57.1	83.0	3.78	95.9	23.0	60.4	60.7	85.6	3.81	98.6	23.5	60.7		
		90	71.2	91.3	3.86	104.4	24.6	61.3	75.4	93.2	3.90	106.5	24.9	61.6	79.7	95.1	3.94	108.6	25.1	61.8		
		110	89.0	102.1	3.97	115.6	26.6	62.5	93.8	103.3	4.02	117.0	26.6	62.7	98.6	104.6	4.07	118.5	26.6	62.9		
70	10	50	36.8	63.8	4.74	80.0	13.5	86.5	39.6	66.7	4.78	83.0	13.9	87.1	42.4	69.6	4.82	86.1	14.4	87.7		
		70	53.3	80.8	5.03	98.0	16.1	90.2	57.0	83.6	5.08	101.0	16.5	90.8	60.6	86.4	5.14	104.0	16.8	91.4		
		90	69.8	97.8	5.31	115.9	18.4	93.9	74.3	100.5	5.38	118.9	18.7	94.5	78.8	103.3	5.45	121.9	18.9	95.1		
		110	Operation not recommended																			
	14.5	50	36.7	64.5	4.56	80.0	14.1	82.6	39.5	67.4	4.59	83.1	14.7	83.1	42.4	70.4	4.63	86.1	15.2	83.5		
		70	53.4	80.3	4.78	96.6	16.8	85.3	57.1	83.0	4.83	99.5	17.2	85.7	60.7	85.8	4.88	102.4	17.6	86.2		
		90	70.2	96.1	5.00	113.2	19.2	87.9	74.6	98.7	5.07	116.0	19.5	88.4	79.0	101.2	5.13	118.7	19.7	88.8		
		110	Operation not recommended																			
	19	50	36.6	65.1	4.37	80.0	14.9	78.7	39.4	68.1	4.40	83.1	15.5	79.0	42.3	71.1	4.43	86.2	16.0	79.4		
		70	53.6	79.8	4.53	95.2	17.6	80.3	57.2	82.5	4.57	98.1	18.0	80.6	60.8	85.1	4.62	100.9	18.4	80.9		
		90	70.5	94.4	4.68	110.4	20.2	82.0	74.9	96.8	4.75	113.0	20.4	82.3	79.2	99.2	4.81	115.6	20.6	82.5		
		110	87.5	109.1	4.84	125.6	22.5	83.6	92.6	111.2	4.92	127.9	22.6	83.9	97.7	113.2	5.00	130.3	22.6	84.1		
90	10	50	38.3	56.8	6.04	77.4	10.1	106.0	40.8	59.2	6.08	79.9	10.5	106.5	43.3	61.5	6.12	82.4	10.8	107.0		
		70	54.9	73.1	6.36	94.8	12.3	109.5	58.2	75.5	6.41	97.3	12.6	110.1	61.6	77.8	6.46	99.9	12.9	110.6		
		90	71.6	89.4	6.68	112.2	14.2	113.1	75.7	91.8	6.74	114.8	14.5	113.7	79.8	94.1	6.81	117.4	14.7	114.2		
		110	Operation not recommended																			
	14.5	50	38.1	57.5	5.82	77.4	9.9	102.2	40.7	59.9	5.85	79.9	10.2	102.6	43.2	62.4	5.88	82.4	10.6	103.0		
		70	54.9	73.2	6.07	93.9	12.1	104.8	58.2	75.5	6.11	96.4	12.4	105.2	61.6	77.9	6.16	98.9	12.6	105.6		
		90	71.7	88.8	6.32	110.4	14.0	107.5	75.8	91.1	6.38	112.9	14.3	107.9	79.9	93.4	6.43	115.3	14.5	108.2		
		110	Operation not recommended																			
	19	50	38.0	58.3	5.60	77.4	11.2	98.4	40.6	60.7	5.63	79.9	11.6	98.7	43.1	63.2	5.65	82.5	12.0	99.0		
		70	54.9	73.3	5.79	93.0	13.5	100.1	58.2	75.6	5.82	95.4	13.9	100.4	61.5	77.9	5.85	97.9	14.2	100.6		
		90	71.8	88.3	5.97	108.6	15.7	101.8	75.9	90.4	6.01	110.9	16.0	102.0	80.0	92.6	6.06	113.3	16.2	102.3		
		110	Operation not recommended																			
110	10	50	39.7	49.8	7.34	74.9	6.8	125.4	42.0	51.6	7.38	76.8	7.0	125.8	44.2	53.4	7.41	78.7	7.2	126.2		
		70	56.5	65.4	7.69	91.6	8.5	128.9	59.5	67.3	7.74	93.7	8.7	129.3	62.5	69.2	7.78	95.8	8.9	129.7		
		90	Operation not recommended																			
		110	Operation not recommended																			
	14.5	50	39.6	50.6	7.09	74.8	7.1	121.8	41.8	52.5	7.11	76.7	7.4	122.1	44.1	54.4	7.14	78.7	7.6	122.4		
		70	56.4	66.1	7.37	91.2	9.0	124.4	59.4	68.0	7.40	93.3	9.2	124.7	62.4	69.9	7.44	95.3	9.4	125.0		
		90	Operation not recommended																			
		110	Operation not recommended																			
	19	50	39.4	51.4	6.83	74.7	7.5	118.1	41.7	53.4	6.85	76.7	7.8	118.3	44.0	55.3	6.87	78.7	8.0	118.5		
		70	56.2	66.7	7.04	90.8	9.5	119.9	59.3	68.7	7.07	92.8	9.7	120.1	62.3	70.7	7.09	94.9	10.0	120.3		
		90	Operation not recommended																			
		110	Operation not recommended																			

NSW075 - Performance Data cont.

Heating Capacity

Source		Load Flow-10 GPM							Load Flow-14.5 GPM							Load Flow-19 GPM						
EST °F	Flow GPM	ELT °F	LLT °F	HC MBTUH	Power kW	HE MBTUH	COP	LST °F	LLT °F	HC MBTUH	Power kW	HE MBTUH	COP	LST °F	LLT °F	HC MBTUH	Power kW	HE MBTUH	COP	LST °F		
25	14.5	60	Operation not recommended																			
		80	Operation not recommended																			
		100	Operation not recommended																			
		120	Operation not recommended																			
	19	60	72.1	58.8	3.90	45.5	4.42	20.1	68.4	58.9	3.78	46.0	4.57	20.0	66.4	59.0	3.66	46.5	4.72	19.95		
		80	91.8	57.4	5.11	40.0	3.29	20.7	88.2	57.5	4.97	40.6	3.39	20.6	86.2	57.6	4.82	41.1	3.50	20.5		
		100	111.6	56.1	6.32	34.5	2.60	21.3	108.0	56.1	6.15	35.1	2.67	21.2	106.1	56.1	5.98	35.7	2.75	21.1		
		120	131.3	54.7	7.53	29.0	2.13	21.9	127.8	54.7	7.34	29.7	2.18	21.8	125.9	54.7	7.14	30.3	2.24	21.7		
30	10	60	72.6	61.1	3.90	47.8	4.59	20.1	69.6	61.2	3.79	48.3	4.74	20.0	66.7	61.3	3.68	48.7	4.88	20.0		
		80	92.3	59.7	5.12	42.3	3.42	21.3	89.4	59.8	4.99	42.8	3.52	21.2	86.5	59.9	4.85	43.3	3.61	21.1		
		100	112.0	58.4	6.35	36.7	2.69	22.4	109.2	58.4	6.19	37.3	2.77	22.3	106.3	58.4	6.03	37.9	2.84	22.2		
		120	131.8	57.0	7.57	31.2	2.21	23.6	129.0	57.0	7.39	31.8	2.26	23.4	126.2	57.0	7.20	32.4	2.32	23.3		
	14.5	60	73.1	63.5	3.9	50.1	4.74	22.2	70.0	63.6	3.82	50.5	4.88	22.2	66.9	63.7	3.7	51.0	5.03	22.1		
		80	92.7	61.7	5.2	44.1	3.51	23.2	89.7	61.8	5.02	44.6	3.60	23.1	86.7	61.9	4.9	45.2	3.71	23.0		
		100	112.4	59.9	6.4	38.1	2.75	24.1	109.4	60.0	6.23	38.7	2.82	24.0	106.5	60.1	6.1	39.4	2.90	23.9		
		120	132.0	58.2	7.6	32.1	2.24	25.0	129.2	58.2	7.43	32.8	2.29	24.9	126.3	58.3	7.2	33.5	2.36	24.8		
	19	60	73.6	65.8	3.95	52.3	4.88	24.3	70.4	65.9	3.84	52.8	5.03	24.3	67.2	66.0	3.73	53.3	5.18	24.2		
		80	93.1	63.6	5.19	45.9	3.59	25.0	90.0	63.7	5.05	46.5	3.70	25.0	86.9	63.8	4.92	47.1	3.80	24.9		
		100	112.7	61.5	6.43	39.5	2.80	25.7	109.7	61.6	6.27	40.2	2.88	25.6	106.7	61.7	6.10	40.8	2.96	25.6		
		120	132.2	59.3	7.67	33.1	2.27	26.4	129.3	59.4	7.48	33.9	2.33	26.3	126.5	59.5	7.29	34.6	2.39	26.2		
	50	10	60	76.7	81.0	4.2	66.7	5.60	36.2	72.7	81.0	4.02	67.3	5.85	36.1	68.8	81.0	3.9	67.8	6.10	36.0	
			80	96.1	78.2	5.4	59.6	4.17	37.7	92.3	78.2	5.24	60.3	4.34	37.6	88.5	78.3	5.1	61.0	4.50	37.4	
			100	115.5	75.3	6.7	52.5	3.28	39.2	111.9	75.4	6.46	53.3	3.39	39.0	108.2	75.5	6.3	54.2	3.51	38.8	
			120	134.9	72.5	7.9	45.4	2.66	40.6	131.4	72.6	7.69	46.4	2.75	40.4	127.9	72.8	7.5	47.3	2.84	40.2	
14.5		60	77.4	84.5	4.2	70.1	5.86	39.1	73.3	84.4	4.07	70.5	6.08	39.1	69.2	84.3	3.9	71.0	6.32	39.0		
		80	96.7	81.1	5.5	62.4	4.35	40.3	92.8	81.1	5.29	63.1	4.50	40.2	88.8	81.2	5.1	63.7	4.66	40.1		
		100	116.0	77.7	6.7	54.8	3.39	41.5	112.2	77.9	6.51	55.7	3.51	41.4	108.5	78.0	6.3	56.5	3.63	41.2		
		120	135.3	74.4	8.0	47.2	2.74	42.7	131.7	74.6	7.73	48.2	2.83	42.5	128.1	74.8	7.5	49.3	2.93	42.3		
19		60	78.1	87.9	4.3	73.4	5.98	42.0	73.8	87.8	4.11	73.8	6.19	42.0	69.5	87.7	4.0	74.1	6.40	42.0		
		80	97.3	84.0	5.5	65.2	4.42	42.9	93.2	84.1	5.33	65.9	4.58	42.9	89.1	84.1	5.2	66.5	4.74	42.8		
		100	116.5	80.2	6.8	57.1	3.44	43.8	112.6	80.3	6.55	58.0	3.57	43.7	108.7	80.5	6.3	58.9	3.69	43.6		
		120	135.7	76.3	8.0	48.9	2.77	44.7	132.0	76.6	7.77	50.1	2.87	44.6	128.3	76.9	7.5	51.2	2.98	44.4		
70		10	60	80.8	100.9	4.48	85.6	6.60	52.3	75.9	100.8	4.26	86.3	6.96	52.2	70.9	100.7	4.03	86.9	7.32	52.1	
			80	99.9	96.6	5.74	77.0	4.93	54.1	95.2	96.6	5.50	77.8	5.16	54.0	90.5	96.6	5.26	78.7	5.39	53.8	
			100	119.0	92.2	7.00	68.3	3.86	55.9	114.5	92.4	6.74	69.4	4.02	55.7	110.0	92.6	6.48	70.4	4.18	55.5	
			120	138.1	87.9	8.26	59.7	3.12	57.7	133.9	88.2	7.99	60.9	3.24	57.4	129.6	88.5	7.71	62.2	3.36	57.2	
	14.5	60	81.7	105.5	4.5	90.0	6.84	56.0	76.6	105.2	4.32	90.5	7.14	56.0	71.4	105.0	4.1	91.0	7.48	55.9		
		80	100.7	100.5	5.8	80.8	5.09	57.5	95.8	100.5	5.55	81.5	5.30	57.4	90.9	100.5	5.3	82.3	5.53	57.2		
		100	119.7	95.6	7.0	71.5	3.97	58.9	115.1	95.7	6.79	72.6	4.13	58.7	110.4	95.9	6.5	73.7	4.31	58.6		
		120	138.7	90.6	8.3	62.2	3.19	60.3	134.3	91.0	8.02	63.6	3.32	60.1	129.9	91.4	7.7	65.0	3.46	59.9		
	19	60	82.7	110.0	4.55	94.5	7.08	59.7	77.3	109.7	4.38	94.7	7.35	59.7	71.9	109.3	4.20	95.0	7.62	59.7		
		80	101.5	104.4	5.82	84.6	5.26	60.8	96.4	104.4	5.60	85.2	5.47	60.7	91.3	104.3	5.39	85.9	5.67	60.7		
		100	120.4	98.9	7.09	74.7	4.09	61.9	115.6	99.1	6.83	75.8	4.26	61.8	110.8	99.3	6.57	76.9	4.43	61.7		
		120	139.2	93.3	8.36	64.8	3.27	63.0	134.7	93.8	8.06	66.3	3.42	62.8	130.2	94.3	7.76	67.8	3.56	62.6		
	90	10	60	84.8	120.1	4.74	103.9	7.42	68.6	78.6	117.4	4.45	102.2	7.75	68.9	72.4	114.6	4.16	100.4	8.07	69.3	
			80	103.7	114.9	6.02	94.4	5.59	70.5	97.9	113.2	5.71	93.7	5.82	70.7	92.1	111.5	5.39	93.1	6.06	70.8	
			100	Operation not recommended																		
		14.5	60	85.3	122.8	4.77	106.5	7.55	73.4	79.0	119.5	4.49	104.2	7.80	73.7	72.6	116.2	4.22	101.8	8.08	74.0	
80			104.2	117.6	6.07	96.8	5.67	74.9	98.3	115.4	5.76	95.8	5.88	75.0	92.3	113.3	5.44	94.7	6.10	75.2		
100			123.2	112.4	7.38	87.2	4.46	76.4	117.6	111.4	7.02	87.4	4.65	76.4	112.0	110.4	6.67	87.7	4.85	76.3		
120			Operation not recommended																			
19		60	85.9	125.4	4.79	109.1	7.67	78.2	79.3	121.6	4.53	106.1	7.88	78.5	72.8	117.8	4.27	103.2	8.08	78.8		
		80	104.8	120.2	6.13	99.3	5.75	79.2	98.6	117.7	5.81	97.9	5.95	79.4	92.5	115.2	5.49	96.4	6.15	79.5		
		100	123.7	115.0	7.46	89.5	4.51	80.3	118.0	113.8	7.08	89.6	4.72	80.3	112.2	112.5	6.70	89.7	4.92	80.3		
		120	Operation not recommended																			

Wiring Schematics

NSW Heating Only - 208-230/60/1

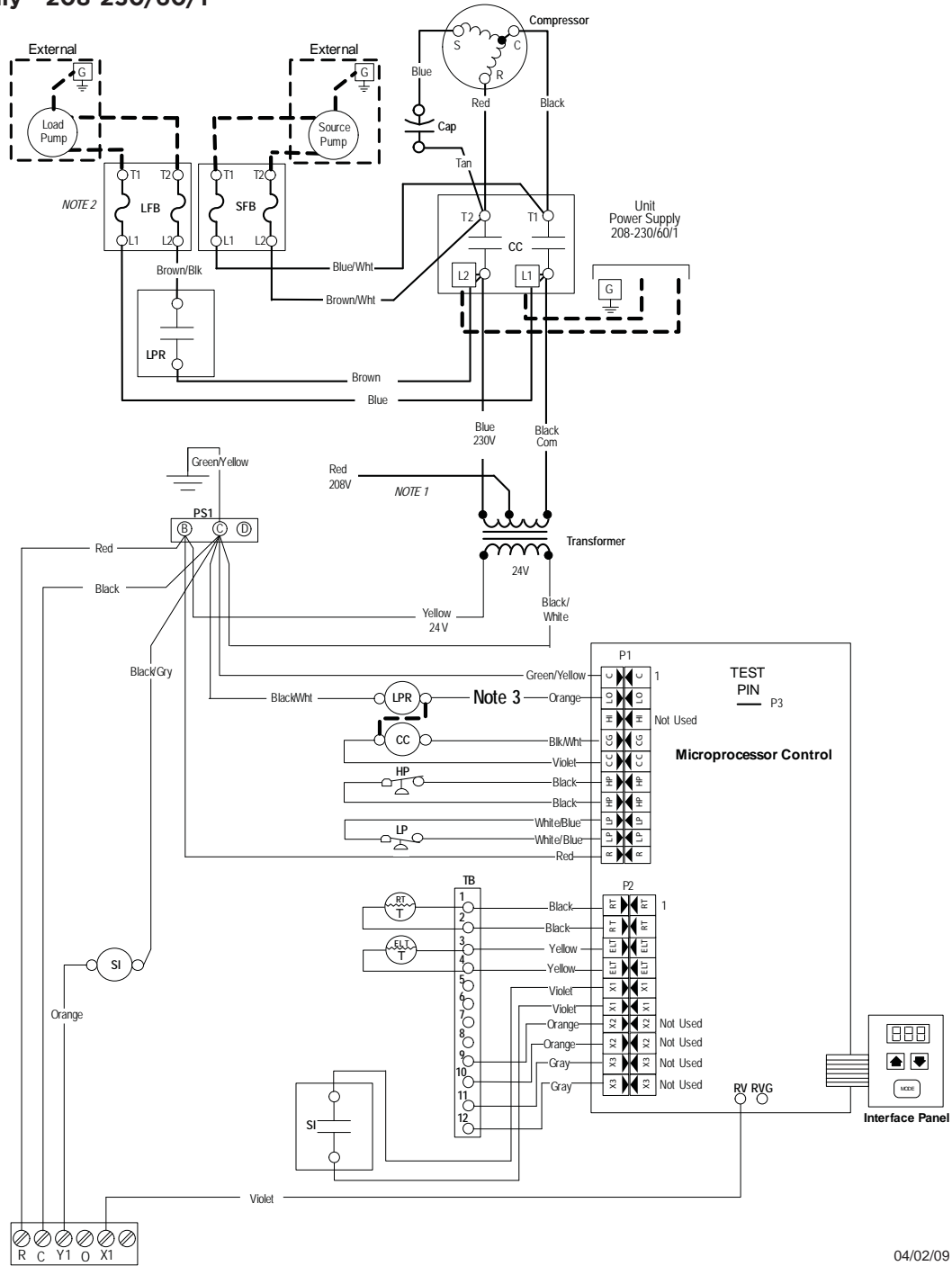

04/02/09

Legend			
<p>— Factory low voltage wiring</p> <p>— Factory line voltage wiring</p> <p>- - - Field low voltage wiring</p> <p>- - - Field line voltage wiring</p> <p>· · · Optional block</p> <p>○ Quick connect terminal</p> <p>⊗ Screw terminal - field connection</p> <p>⊕ Fuse</p>	<p>CC - Compressor contactor</p> <p>RV - Reversing Valve output</p> <p>ELT - Entering Load Side Water Temperature</p> <p>HP - High pressure switch</p> <p>LP - Low pressure switch</p> <p>LPR - Load Pump Relay</p> <p>RT - Refrigerant Liquid line Temperature</p> <p>SI - Slave Input relay</p> <p>RC - Reversing Valve Coil</p> <p>LFB - Load Pump Fuse Block</p> <p>SFB - Source Pump Fuse Block</p>	<p>L1 Field wire lug</p> <p>⊕ Ground</p> <p>⊕/⊖ Relay Contacts - N.O., N.C.</p> <p>P Polarized connector</p>	<p>⊕ Switch - High pressure</p> <p>⊖ Switch - Low pressure</p> <p>⊕ Relay coil</p> <p>⊕ Capacitor</p> <p>⊕ Thermistor</p>
			<p>Notes:</p> <ol style="list-style-type: none"> 1. Taped and wire tied off 2. 3AG10 Amp fuse 3. For cycle load pump with a geo storage tank. Remove the orange wire from the LPR relay coil and install a jumper between the LPR relay coil and the comp contactor coil as shown in the schematic above.

Wiring Schematics cont.

NSW Reversible with IntelliStart - 208-230/60/1

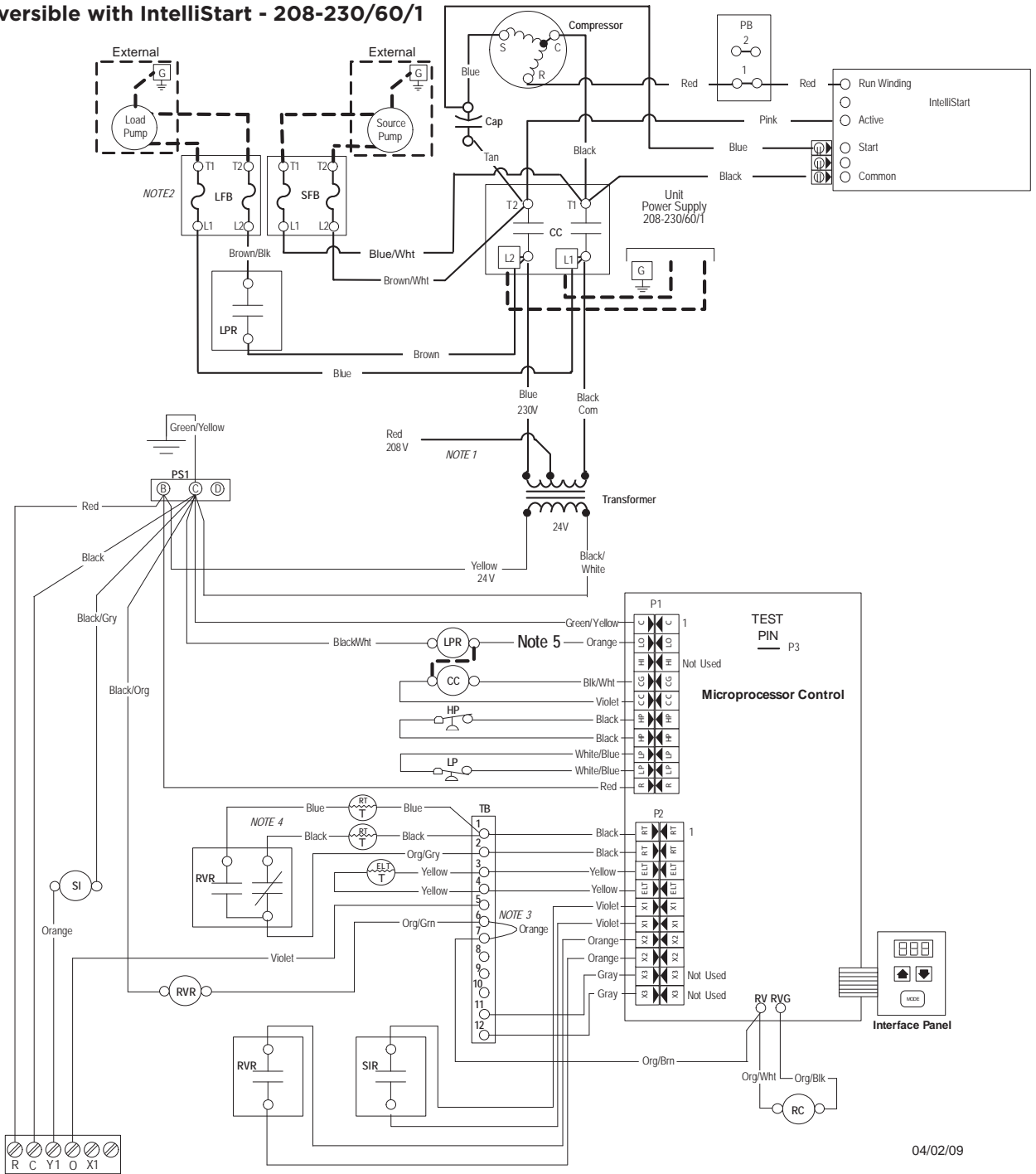

04/02/09

Legend			
<p>— Factory low voltage wiring</p> <p>— Factory line voltage wiring</p> <p>- - - Field low voltage wiring</p> <p>- - - Field line voltage wiring</p> <p>- - - Optional block</p> <p>○ Quick connect terminal</p> <p>⊗ Screw terminal - field connection</p> <p>— Fuse</p>	<p>CC - Compressor Contactor</p> <p>RV - Reversing Valve Output</p> <p>ELT - Entering Load Side Water Temperature</p> <p>HP - High Pressure Switch</p> <p>LP - Low Pressure Switch</p> <p>LPR - Load Pump Relay Contacts</p> <p>RT - Refrigerant Liquid Line Temperature</p> <p>SIR - Slave Input Relay</p> <p>RC - Reversing Valve Coil</p> <p>LFB - Load Pump Fuse Block</p> <p>SFB - Source Pump Fuse Block</p> <p>RVR - Reversing Valve Relay</p>	<p>L1 Field wire lug</p> <p>⊕ Ground</p> <p>Relay Contacts - N.O., N.C.</p> <p>P Polarized connector</p>	<p>Switch - High pressure</p> <p>Switch - Low pressure</p> <p>Relay coil</p> <p>Capacitor</p> <p>Thermistor</p>
<p>Notes:</p> <ol style="list-style-type: none"> 1. Taped and wire tied off 2. 3AG 10Amp fuse 3. Move jumper wire to 5 and 6 for reversible secondary unit. 4. Black Thermistor - Source Coax Blue Thermistor - Load Coax 5. For cycle load pump with a geo storage tank. Remove the orange wire from the LPR relay coil and install a jumper between the LPR relay coil and the comp contactor coil as shown in the schematic above. 			

Wiring Schematics - Commercial

NSW Heating Only - 208-230/60/3

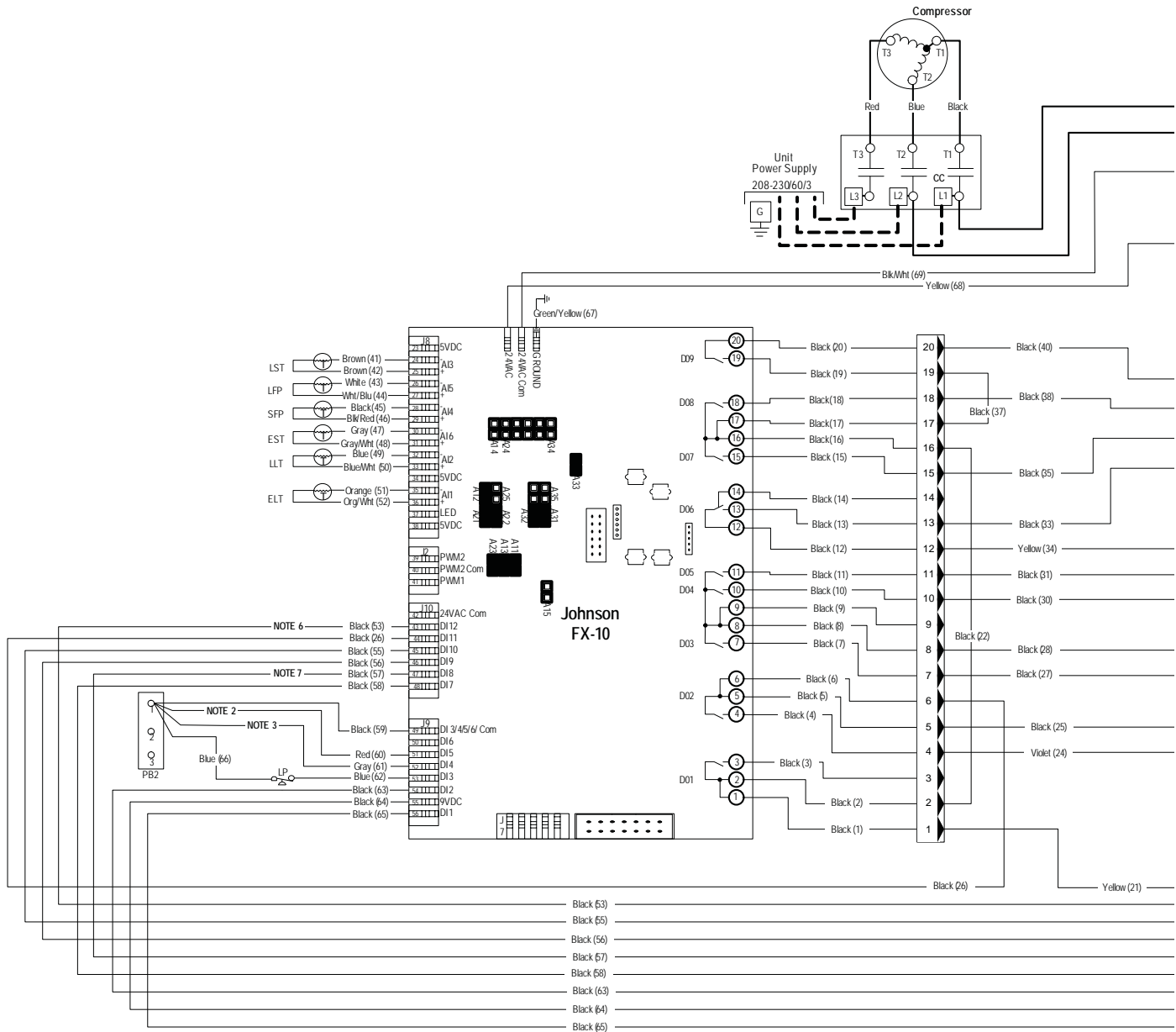

97P799-05

4/02/09

Legend

<p>— Factory low voltage wiring</p> <p>— Factory line voltage wiring</p> <p>— Field low voltage wiring</p> <p>— Field line voltage wiring</p> <p>--- Optional block</p> <p>--- Field Zone Sensor Wiring</p>	<p>● Internal junction</p> <p>[L1] Field wire lug</p> <p>⊥ Ground</p> <p>⊥/⊥ Relay Contacts - N.O., N.C.</p> <p>⊕ Thermistor</p> <p>⊕ Relay coil</p>	<p>⊕ Switch - High pressure</p> <p>⊕ Switch - Low pressure</p> <p>⊕ Open Jumper</p> <p>⊕ Closed Jumper</p> <p>P Polarized connector</p>	<p>CC - Compressor contactor</p> <p>CP - Compressor Proving</p> <p>ELT - Entering Load Water Temp</p> <p>ES - Emergency Shutdown</p> <p>EST - Entering Source Water Temp</p> <p>HP - High pressure switch</p> <p>LFP - Load Freeze Protection</p> <p>LFS - Load Flow Proving Switch</p> <p>LLT - Leaving Load Water Temp</p> <p>LP - Low pressure switch</p> <p>LST - Leaving Source Water Temp</p> <p>RV - Reversing Valve coil</p> <p>SFP - Source Freeze Protection</p> <p>SFS - Source Flow Proving Switch</p> <p>TB - Terminal Board</p>	<p>Notes:</p> <ol style="list-style-type: none"> 1 - Switch Blue and Red wires for 208V operation 2 - Disconnect for 15 degree load side freeze detection 3 - Disconnect for 15 degree source side freeze detection 4 - Acc 1 and ACC 2 outputs are cycled with the compressor. 5 - R, C, Y1, and O inputs are for use with an aqua stat. 6 - If no flow proving switch is being used on the load side, the LF terminal on the terminal board must be jumpered to the R terminal for the unit to operate. 7 - If no flow proving switch is being used on the source side, the SF terminal on the terminal board must be jumpered to the R terminal for the unit to operate. 8 - A closed contact will enable the emergency shutdown input (ES) and the compressor proving input (CP). 9 - Primary over-ride input (POI) on a primary unit must be wired to R through a normally open contact. If the POI input is on a secondary unit connect the Primary Over-ride output (PO) from the primary unit to the POI terminal on the secondary unit. 10 - Apply 24VAC to the O terminal for cooling.
---	--	---	---	---

Wiring Schematics - Commercial cont.

NSW Heating Only - 208-230/60/3

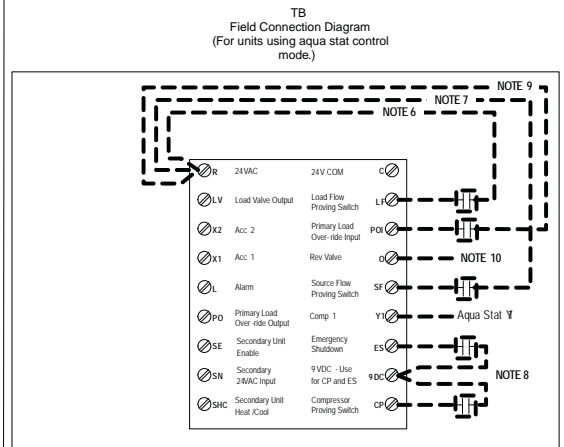
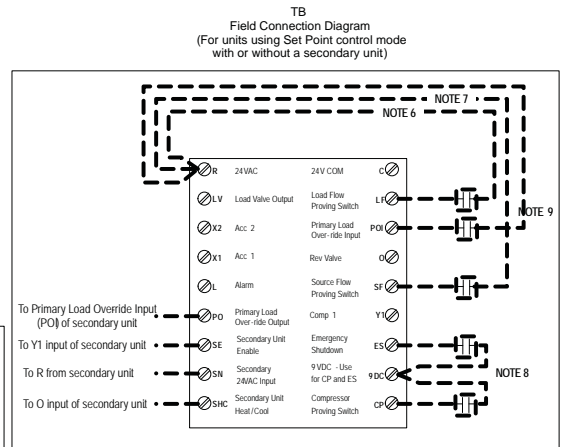
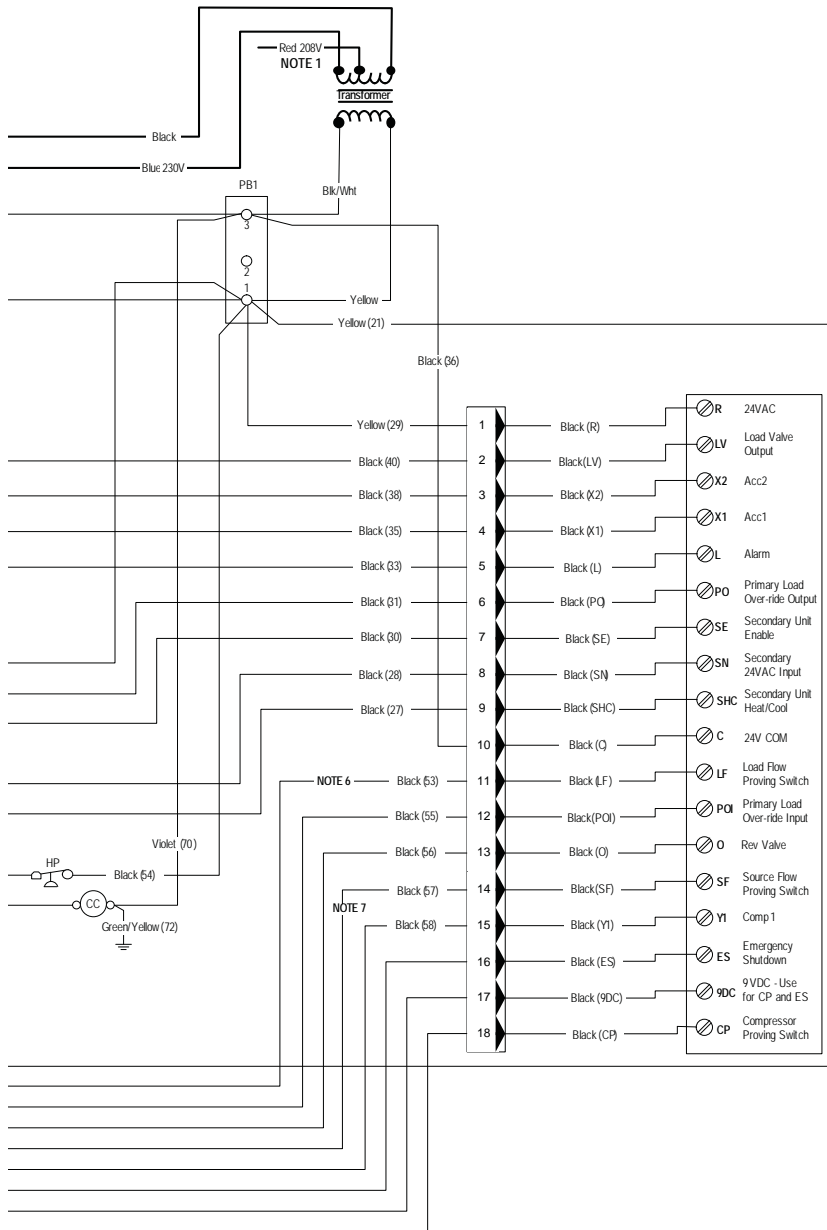

97P799-05

4/02/09

Wiring Schematics - Commercial cont.

NSW Reversible - 575/460/3

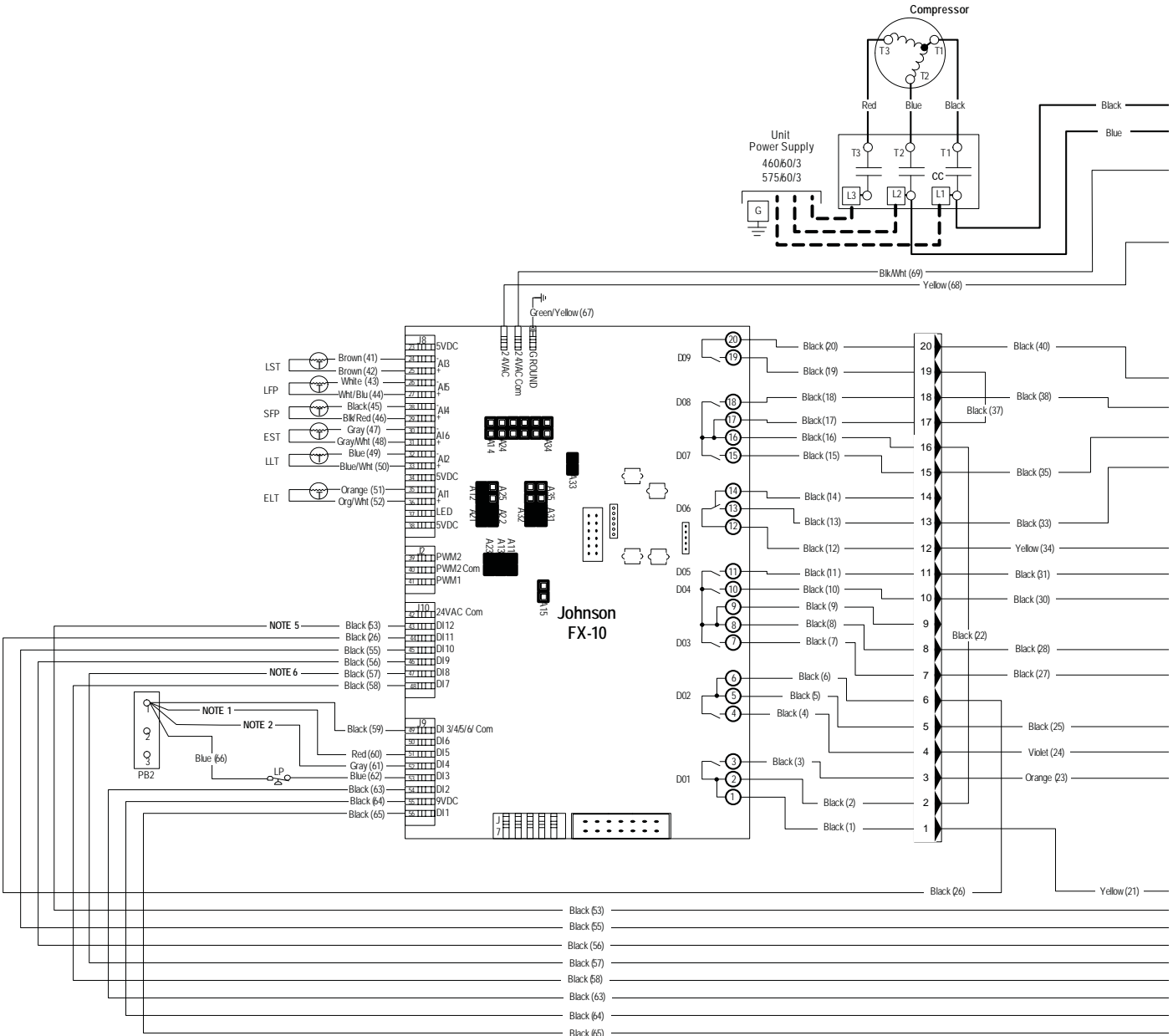

97P799-08

4/02/09

Legend			
	Factory low voltage wiring		Internal junction
	Factory line voltage wiring		Field wire lug
	Field low voltage wiring		Ground
	Field line voltage wiring		Relay Contacts- N.O., N.C.
	Optional block		Thermistor
	Field Zone Sensor Wiring		Relay coil
			Open Jumper
			Closed Jumper
			Switch - High pressure
			Switch - Low pressure
			Polarized connector
			CC - Compressor contactor
			CP - Compressor Proving
			ELT - Entering Load Water Temp
			ES - Emergency Shutdown
			EST - Entering Source Water Temp
			HP - High pressure switch
			LFP - Load Freeze Protection
			LFS - Load Flow Proving Switch
			LLT - Leaving Load Water Temp
			LP - Low pressure switch
			LST - Leaving Source Water Temp
			RV - Reversing Valve coil
			SFP - Source Freeze Protection
			SFS - Source Flow Proving Switch
			TB - Terminal Board
		Notes:	
		1 - Disconnect for 15 degree load side freeze detection	
		2 - Disconnect for 15 degree source side freeze detection	
		3 - Acc 1 and ACC 2 outputs are cycled with the compressor.	
		4 - R, C, Y1, and O inputs are for use with an aqua stat.	
		5 - If no flow proving switch is being used on the load side, the LF terminal on the terminal board must be jumpered to the R terminal for the unit to operate.	
		6 - If no flow proving switch is being used on the source side, the SF terminal on the terminal board must be jumpered to the R terminal for the unit to operate.	
		7 - A closed contact will enable the emergency shutdown input (ES) and the compressor proving input (CP).	
		8 - Primary over-ride input (POI) on a primary unit must be wired to R through a normally open contact. If the POI input is on a secondary unit connect the Primary Over-ride output (PO) from the primary unit to the POI terminal on the secondary unit.	
		9 - Apply 24VAC to the O terminal for cooling.	

Wiring Schematics - Commercial cont.

NSW Reversible - 575/460/3

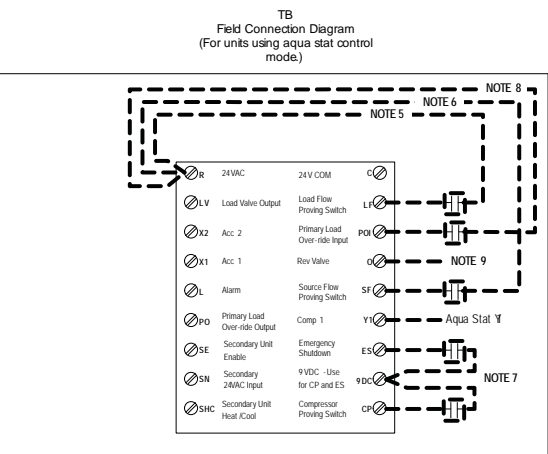
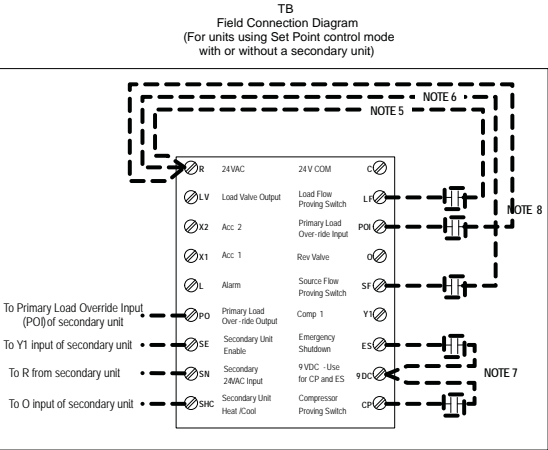
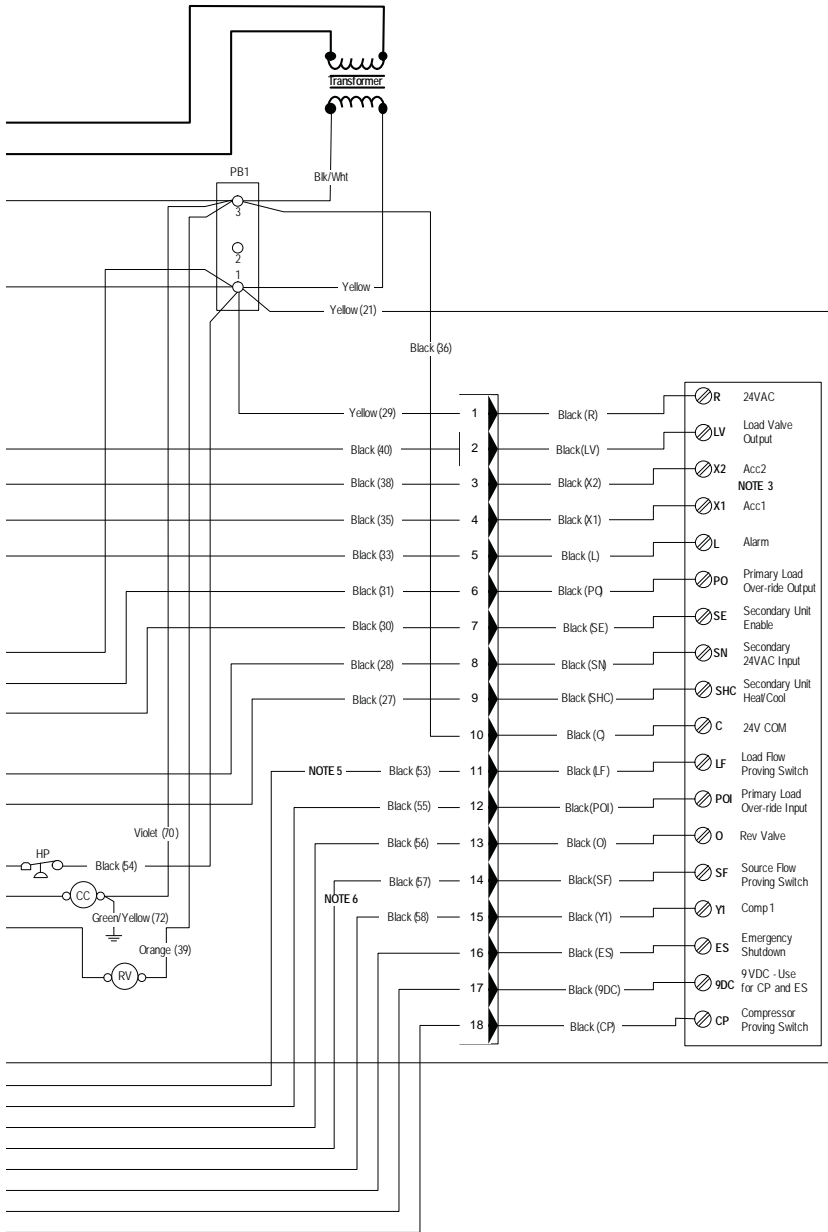

97P799-08

4/02/09

Accessories and Options

IntelliStart

IntelliStart is a single phase compressor soft starter which reduces the normal start current (LRA) by 60-70%. It should be used in applications that require low starting amps, reduced compressor start-up noise, off-grid, and improved start-up behavior. IntelliStart is available as a factory installed option or a field installed kit (**IS60RKL** or **IS60RKS**). IntelliStart is available on 208-230/60/1 voltage.

Water Connection Kits (Field Installed)

Water connection kits are available to facilitate loop side and load side water connections.

- **MA4FPT** - Forged brass 1" MPT x 1" FPT square street elbow with P/T plug for NSW018-NSW040 water side connections
- **MA5FPT** - Forged brass 1.25" MPT x 1.25" FPT square street elbow with P/T plug for NSW050-NSW075 water side connections
- **HKC8S** - 1 inch x 24 inch stainless steel braided hose kit
- **HKC10S** - 1 1/4 inch x 24 inch stainless steel braided hose kit

Earth Loop Pump Kit (Field Installed)

A specially designed one or two-pump module provides all liquid flow, fill and connection requirements for independent single unit systems (230/60/1 only). The one-pump module (FC1-FPT or FC1-GL) is capable of 25 feet of head at 16.0 GPM, while the two-pump module (FC2-FPT or FC1-GL) is capable of 50 feet of head at 16.0 GPM.

Hot Water Generator (Factory Installed, NSW040, NSW050, NSW060, and NSW075 Only)

An optional heat reclaiming hot water generator coil constructed of vented double-wall copper construction suitable for potable water is available. The coil is factory mounted inside the unit. A DPK5 pump kit (230/60/1) is required (field installed), which includes a DHW tank connection and a temperature limit pump shutoff.

Load-side Pump Kit (Field Installed)

Four (4) load pump kits are available to provide all liquid flow requirements for independent single unit systems (230/60/1 only). WaterFurnace part number **24P501A04** (Grundfos UP15-42B7) and **EWPK2** (Grundfos UP26-64BF) are bronze body pumps. Bronze body pumps should be used when water conditions exist that are not compatible with cast iron or for applications such as domestic water heating. WaterFurnace part number **EWPK1** and **EWPK3** come with a cast iron body pump (Grundfos UP26-99F) that can be used for hydronic heating applications.

Calculate the system pressure drop then refer to the pump curves in figures 7 and 8 to select the proper pump. All four (4) of the WaterFurnace pump kits can be used for hydronic heating applications as long as they meet the flow requirements. If the flow requirements are outside the

pump curve, an alternate pump will need to be obtained to maintain the necessary flow.

- **24P501A04** - UP15-42B7 bronze volute, 3/4 inch sweat connection
- **EWPK1** - UP26-99F cast iron volute, 1 inch FPT flange connection
- **EWPK2** - UP26-64BF bronze volute, 1 inch FPT flange connection
- **EWPK3** - UP26-99F cast iron volute, 1-1/4 inch FPT flange connection

HydroZone Tank Controller

Tank controller (**HZC**) that adds outdoor reset with warm weather shutdown, setpoint control, process control, and management of four compressor outputs for our water-to-water systems.

HZAB

This is used in conjunction with the HydroZone to control the Geo-Storage tank electric heating element.

Figure 7: UP15-42B7, UP26-64BF, and UP26-99F Single Pump Curve

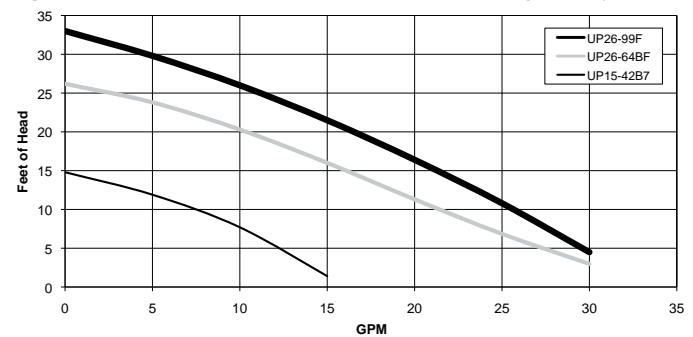
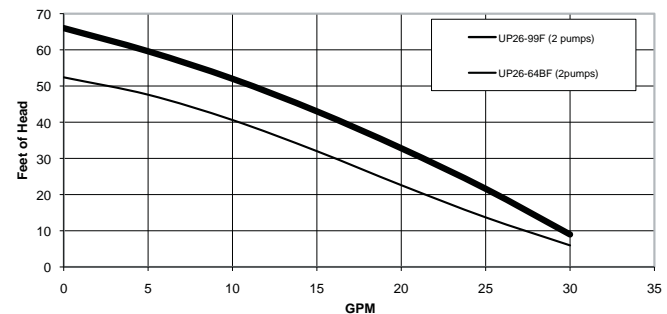
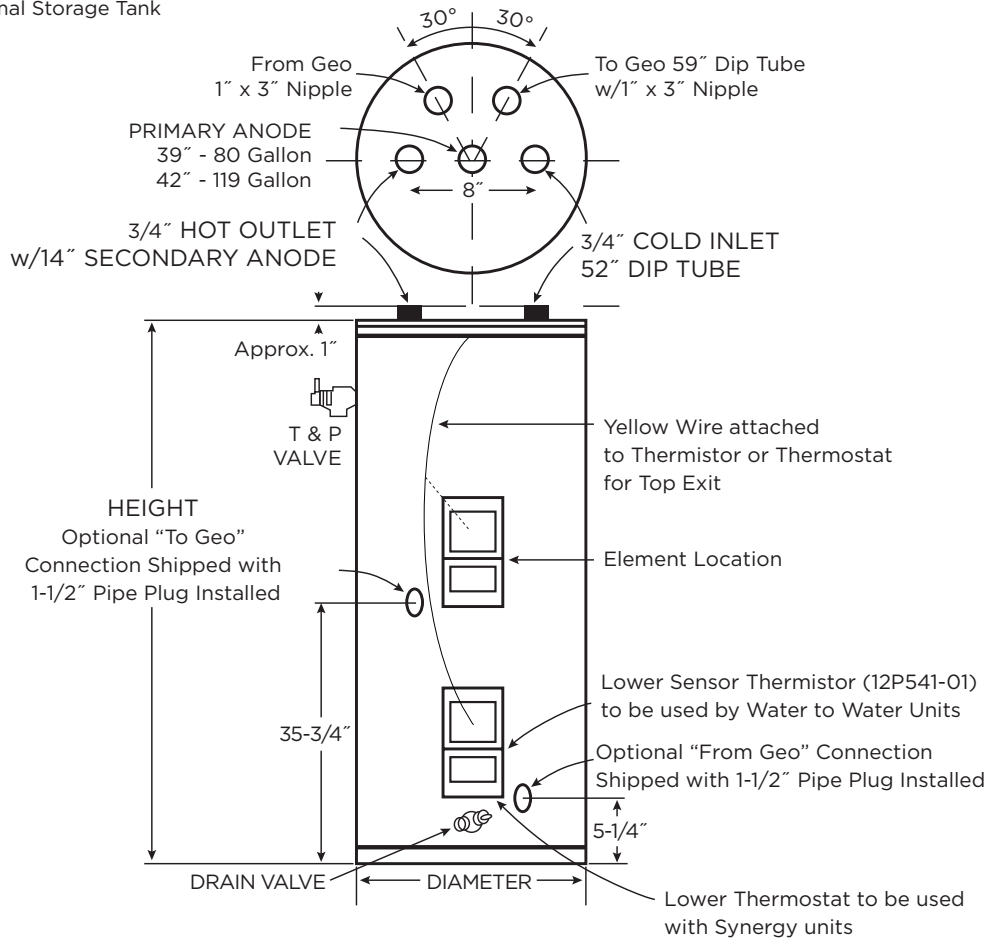

Figure 8: UP26-64BF and UP26-99F Two Pump Curve



Accessories and Options cont.

Figure 9: Geothermal Storage Tank



MODEL NUMBER	GALLON CAPACITY	ELEMENT WATTAGE (240 VOLT)	NUMBER OF ELEMENTS	R VALUE	DIMENSIONS IN INCHES		APPROX. SHIPPING WEIGHT (lbs.)
					HEIGHT	DIAMETER	
GEO-STORAGE-80	80	4500	1	16	63-1/4	24	204
GEO-STORAGE-120	119	4500	1	16	63-1/4	28	311

Engineering Guide Specifications

General

The liquid source water-to-water heat pump shall be a single packaged heating only or reverse-cycle heating/cooling unit. Dedicated non-reversing heating only units shall be easily field convertible to cooling only units. The unit shall be listed by a nationally recognized safety-testing laboratory or agency, such as ETL Testing Laboratory, Underwriters Laboratory (UL), or Canadian Standards Association (CSA). The unit shall be rated in accordance with Air Conditioning, Heating, and Refrigeration Institute/International Standards Organization (AHRI/ISO) and Canadian Standards Association (CSA-US). The liquid source water-to-water heat pump unit, as manufactured by WaterFurnace International, Fort Wayne, Indiana, shall be designed to operate with source liquid temperatures between 30°F [-1.1°C] and 110°F [43.3°C] in cooling, and between 25°F [-3.9°C] and 90°F [32.2°C] in heating.

Casing and Cabinet

The cabinet shall be fabricated from heavy-gauge galvanized steel and finished with corrosion-resistant powder coating. This corrosion protection system shall meet the stringent 1,000 hour salt spray test per ASTM B117. The interior shall be insulated with ½ in. thick, multi-density, coated glass fiber for noise suppression.

All units shall have separate holes and knockouts for entrance of line voltage and low voltage control wiring. All factory-installed wiring passing through factory knockouts and openings shall be protected from sheet metal edges at openings by plastic ferrules. The control box shall be field switchable from front to back for improved application flexibility with quick attach low voltage harnesses. The control box is shipped standard on the opposite end of the water connections.

Refrigerant Circuit

All units shall utilize the non-ozone depleting and low global warming potential refrigerant R-410A. All units shall contain a sealed refrigerant circuit including a hermetic motor-compressor, bidirectional thermostatic expansion valve, reversing valve, coaxial tube water-to-refrigerant heat exchanger, optional hot water generator coil, and service ports. An optional vented double wall load coaxial water-to-refrigerant heat exchanger is available on O18 and O25.

Compressors shall be high-efficiency scroll type designed for heat pump duty and mounted on vibration isolators. The compressor shall be double isolation mounted using selected durometer grommets to provide vibration free compressor mounting. All models will feature a compressor discharge muffler to help quiet compressor gas pulsations. A high density sound attenuating blanket shall be factory installed around the compressor to reduce sound. Compressor motors shall be single-phase PSC with overload protection.

The coaxial water-to-refrigerant heat exchanger shall be designed for low water pressure drop and constructed of a convoluted copper (cupronickel option) inner tube and a steel outer tube. Refrigerant-to-water heat exchangers shall be of copper inner water tube and steel refrigerant outer tube design, rated to withstand 600 PSIG (4135 kPa) working refrigerant pressure and 450 PSIG (3101 kPa) working water pressure. The thermostatic expansion valve shall provide proper superheat over the entire liquid temperature range with minimal "hunting." The valve shall operate bidirectionally without the use of check valves.

Option: Cupronickel refrigerant-to-water heat exchanger shall be of copper-nickel inner water tube and steel refrigerant outer tube design, rated to withstand 600 PSIG (4135 kPa) working refrigerant pressure and 450 PSIG (3101 kPa) working water pressure. Water lines shall also be of cupronickel construction.

Option: Hot Water Generator (available on O40-O75)

- Internal double wall vented hot water generator coil refrigerant to water heat exchangers shall be of copper inner water tube and steel refrigerant outer tube design, rated to withstand 600 PSIG (4135 kPa) working refrigerant pressure and 450 PSIG (3101 kPa) working water pressure.

Option: Vented double wall water-to-refrigerant heat exchange (available on O18 and O25)

- Internal vented double wall water-to-refrigerant coaxial heat exchangers shall be of copper inner water tube and steel refrigerant outer tube design, rated to withstand 600 PSIG (4136 kPa) working refrigerant pressure and 450 PSIG (3101 kPa) water pressure.

Piping and Connections

Supply and return water connections shall be 1 in. [25.4 mm] for the NSW018-NSW040, 1 ¼ in. [31.75 mm] for the NSW050-NSW075, and all hot water generator water connections shall be ½ in. [12.7 mm] FPT copper fittings. The FPT fittings shall be fixed to the cabinet by use of a captive fitting, which eliminates the need for backup pipe wrenches.

Electrical

A control box shall be located within the unit compressor compartment and shall contain a 75VA transformer with a built-in circuit breaker, 24 volt activated compressor contactor, terminal block for thermostat wiring and solid-state controller for complete unit operation. Electromechanical operation WILL NOT be accepted. Units shall be name-plated for use with time delay fuses or HACR circuit breakers. Unit controls shall be 24 volt and provide heating or cooling as required by the remote thermostat/sensor.

Engineering Guide Specifications cont.

A standard microprocessor-based controller that interfaces with an electronic thermostat to monitor and control unit operation shall be provided. The control shall provide operational sequencing, high and low pressure switch monitoring, freeze detection, hot water limit thermistor sensing, lockout mode control, hot water and loop pump control, LED status and fault indicators, fault memory, field selectable options and accessory output. The control shall provide fault retry three times before locking out to limit nuisance trips. Anti short-cycle protection shall be integral to the control.

A detachable terminal block with screw terminals will be provided for field control wiring. All units shall have knockouts for entrance of low and line voltage wiring.

Option: A FX10 microprocessor-based controller that interfaces with an electronic thermostat to monitor and control unit operation. The control shall provide operational sequencing, high, low, and loss of charge pressure monitoring, freeze detection, lockout mode control, fault memory, field selectable options and accessory output. The control shall communicate all mode, status, fault and lockout codes to the front end system for fast and accurate equipment diagnosis. The control shall provide fault retry three times before locking out to limit nuisance trips.

Optional FX10 microprocessor control communication protocols: N2, LonWorks, BACnet

Optional IntelliStart (compressor Soft Starter) shall be factory installed for use in applications that require low starting amps, reduced compressor start-up noise, off-grid, and improved start-up behavior. IntelliStart shall reduce normal starting current by 60% on 208/60/1 units.

Accessories

Hose Kits – Automatic Balancing and Ball Valves with ‘Y’ strainer (field-installed)

WaterFurnace P/N - HHK81S (1 in. hose kit for 018-040)
HHK100S (1 1/4 in. hose kit for 050-075)

A flexible steel braid hose featuring Kevlar® reinforced EPDM core with ANSI 302/304 stainless steel outer braid and fire rated materials per ASTM E 84-00 (NFPA 255, ANSI/UL 723 & UBC 8-1). Ball valve at one end; swivel connector with adapter at the other end (swivel to adapter connection via fiber or EPDM gasket). Swivel connection provides union between heat pump and piping system. The hoses feature brass fittings, stainless steel ferrules. A “y” strainer is provided on one end for fluid straining and integral “blowdown” valve. A full port ball valve shall be provided with integral P/T (pressure/temperature) port on supply hose and automatic balancing valve with integral P/T ports and full port ball valve on return hose.

Specifications:

- Temperature range of 35°F [2°C] to 180°F [82°C].
- Max. working pressure of 400 psi [2756 kPa] for 1/2 in. and 3/4 in. hose kits; max. working pressure of 350 psi [2413 kPa] for 1 in. and 1 1/4 in. hose kits.
- Minimum burst pressure of four times working pressure.

Notes

Revision Guide

Pages:	Description:	Date:	By:
All	Minor Formatting Corrections	23 Oct 2012	DS
28	Updated AHRI Data Table	23 Oct 2012	DS
9, 11	Updated Cooling Setpoint Values	23 Oct 2012	DS
5, 6, 52	Added Notes Regarding Discharge Mufflers	23 Oct 2012	DS
50	Updated Water Connection Kits	13 Nov 2012	DS
55	Added Revision Guide	23 Oct 2012	DS



Manufactured by
WaterFurnace International, Inc.
9000 Conservation Way
Fort Wayne, IN 46809
www.waterfurnace.com

Product: **Envision NSW**
Type: Geothermal Hydronic Heat Pump
Size: Commercial 1.5-6 Tons
Document: Specification Catalog

SC1056WN 11/12