



ENVISION™

Console 0.75 to 1.5 Ton
Water Source/Geothermal Heat Pump



ENVISION

The Envision Series Console provides cutting edge technology in heating and cooling for commercial applications, using the latest in component and design technology. Single speed, R-410A LG rotary compressors are the heart of the system. Also included are oversized coaxial water-to-refrigerant heat exchangers and durable all-aluminum air coils for high efficiencies at low face velocities. Envision Console units are capable of operating at extreme loop temperatures and have the options and flexibility for any application. The cabinet footprint is designed to match "legacy" consoles for easy retrofitting.

As a leader in the industry, WaterFurnace International is dedicated to innovation, quality and customer satisfaction. Our team of engineers, customer support and skilled assembly technicians are dedicated to providing the highest quality products with the most extensive support network in the industry. By specifying WaterFurnace 0.75-1.5 ton Envision Series Consoles, you can rest assured your customers are investing in a product with superior quality and performance.



Envision Consoles are the perfect fit for any ductless application.

KEY FEATURES

COMPRESSOR: Single speed rotary compressors. Available in commercial single phase voltages.

WATER LINES: 1/2" Copper FPT waterline connections protrude out the end of the chassis for ease of installation.

COAXIAL HEAT EXCHANGER: Oversized and convoluted with copper inner tube (optional cupronickel) and steel outer tube, designed for maximum heat transfer at normal and low water flow rates to minimize pressure drop.

ALUMINUM AIR COIL: An aluminum air coil is featured in all Envision Console units to provide exceptional durability and high efficiencies. Added protection is also available with an optional AlumiSeal™ coating.

MOTORIZED OUTSIDE AIR DAMPER: Optional field installed motorized outside air damper allows for the introduction of 25% outside (fresh) air into the conditioned space. Powered on by a 24V signal to the damper motor and spring-closed upon a loss of signal.

ELECTRIC HEAT: Internally mounted Nickel-Cadmium (Ni-Cad) electric heat elements with ceramic insulators and thermal switches. Available in 1 kW or 2 kW for NC09-12 and 3 kW for NC15-18.

ELECTRICAL DISCONNECT: Optional, field installed fused or non-fused electrical disconnect available. Fused sizes available in 10, 12, 15, 20 and 25 amp fuses.

CABINET: Constructed of heavy gauge environmentally-responsible galvanized steel for maximum corrosion resistance. All cabinets finished with beige textured epoxy powder coating on both sides for added protection. Fits "legacy" console footprints.

REFRIGERANT CIRCUIT: Units utilize R-410A refrigerant in sealed circuits. Metering accomplished with thermostatic expansion valve to deliver optimum refrigerant flow over a wide range of conditions without troublesome check valves. Four-way solenoid activated reversing valve faults to heating, and is "cool brazed" at the factory.

CONTROLS: The Compressor Control Module (CCM) comes standard or an optional Versatec Microprocessor Control is also available. The optional FX10 Control adds N2, Modbus, LON & BACnet compatibility along with unit or wall mounted sensors or wall mounted thermostat options (thermostat/sensors sold separately).

FAN MOTOR: High efficiency, dual shaft, 2 speed PSC or optional 3 speed ECM.

ADDITIONAL OPTIONS:

- EXTENDED RANGE COAXIAL HEAT EXCHANGER AND PIPING INSULATION.
- CABINETS AVAILABLE IN FLAT, SLOPE TOP, OR EXTENDED SLOPE TOP.
- LEFT OR RIGHT CONTROLS
- 115V OPTION ON NC09-12

ENVISION SERIES CONSOLES 0.75 - 1.5 Ton

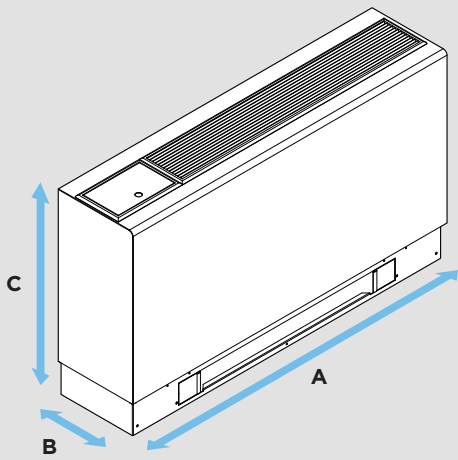

Flat Top

Model	A	B	C
09 - 12	45.0"	10.8"	25.7"
015 - 018	50.0"	12.3"	25.7"

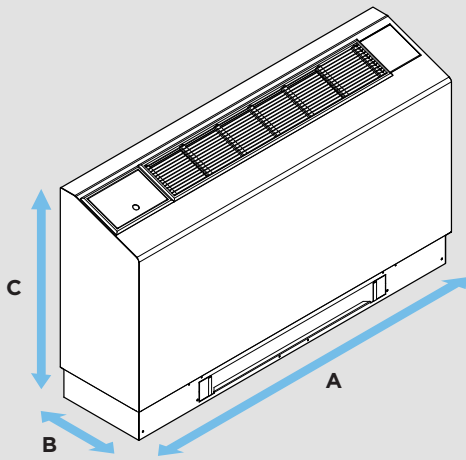

Slope Top

Model	A	B	C
09 - 12	50.0"	12.6"	29.1"
015 - 018	55.0"	12.6"	29.1"

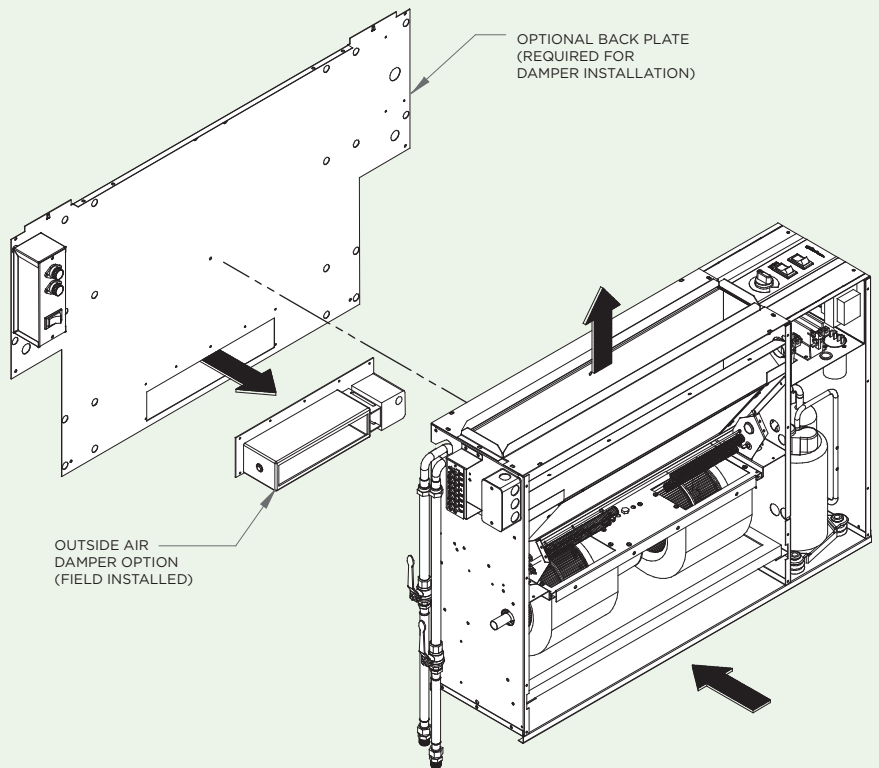

OPTIONAL BACK PLATE
(REQUIRED FOR
DAMPER INSTALLATION)

OUTSIDE AIR
DAMPER OPTION
(FIELD INSTALLED)

Inside the Envision Series Console

ARI/ISO 13256-1 PERFORMANCE RATINGS

PSC & ECM Motors

ARI/ASHRAE/ISO 13256-1

English (IP) Units

Model	Flow Rate		Water Loop Heat Pump				Ground Water Heat Pump				Ground Loop Heat Pump			
			Cooling EWT 86°F		Heating EWT 68°F		Cooling EWT 59°F		Heating EWT 50°F		Cooling EWT 77°F		Heating EWT 32°F	
	gpm	cfm	Capacity Btuh	EER Btuh/W	Capacity Btuh	COP	Capacity Btuh	EER Btuh/W	Capacity Btuh	COP	Capacity Btuh	EER Btuh/W	Capacity Btuh	COP
09	2.5	300	8,500	13.4	10,500	4.4	10,200	22.5	8,700	3.8	9,000	16.0	6,700	3.1
12	3.5	350	10,500	12.3	14,400	4.3	12,400	19.5	11,800	3.7	11,000	14.2	9,500	3.5
15	4.5	450	13,500	13.6	17,000	4.9	16,200	22.0	14,000	4.1	14,200	15.9	10,500	3.4
18	5.5	500	16,200	12.5	21,000	4.4	19,000	19.6	17,000	3.7	16,600	15.1	13,300	3.1

12/09/09

Cooling capacities based upon 80.6°F DB, 66.2°F WB entering air temperature

Heating capacities based upon 68°F DB, 59°F WB entering air temperature

All ratings based upon 208V operation

BR1010CN 03/14



visit us at waterfurnace.com