

ENVISION™ 2 COMPACT

Commercial 0.75 to 6 Ton
Water Source/Geothermal Heat Pump



Table of Contents

Model Nomenclature.....	4
AHRI Data.....	5
The Envision ² Compact.....	7
Inside the Envision ² Compact.....	12
Hot Gas Reheat/Hot Gas Bypass.....	28
Application Notes.....	32
Water Quality.....	34
Installation Notes.....	35
Dimensional Data.....	38
Hanger Bracket Locations.....	42
Physical Data.....	43
Electrical Availability.....	45
Electrical Data.....	46
Blower Performance Data.....	49
Selection Example.....	54
Reference Calculations.....	56
Legend and Notes.....	56
Operating Limits.....	57
Correction Factor Tables.....	57
Pressure Drop.....	58
Performance Data.....	59
Wiring Schematics.....	84
Engineering Guide Specifications.....	87
Revision Guide.....	91

Model Nomenclature

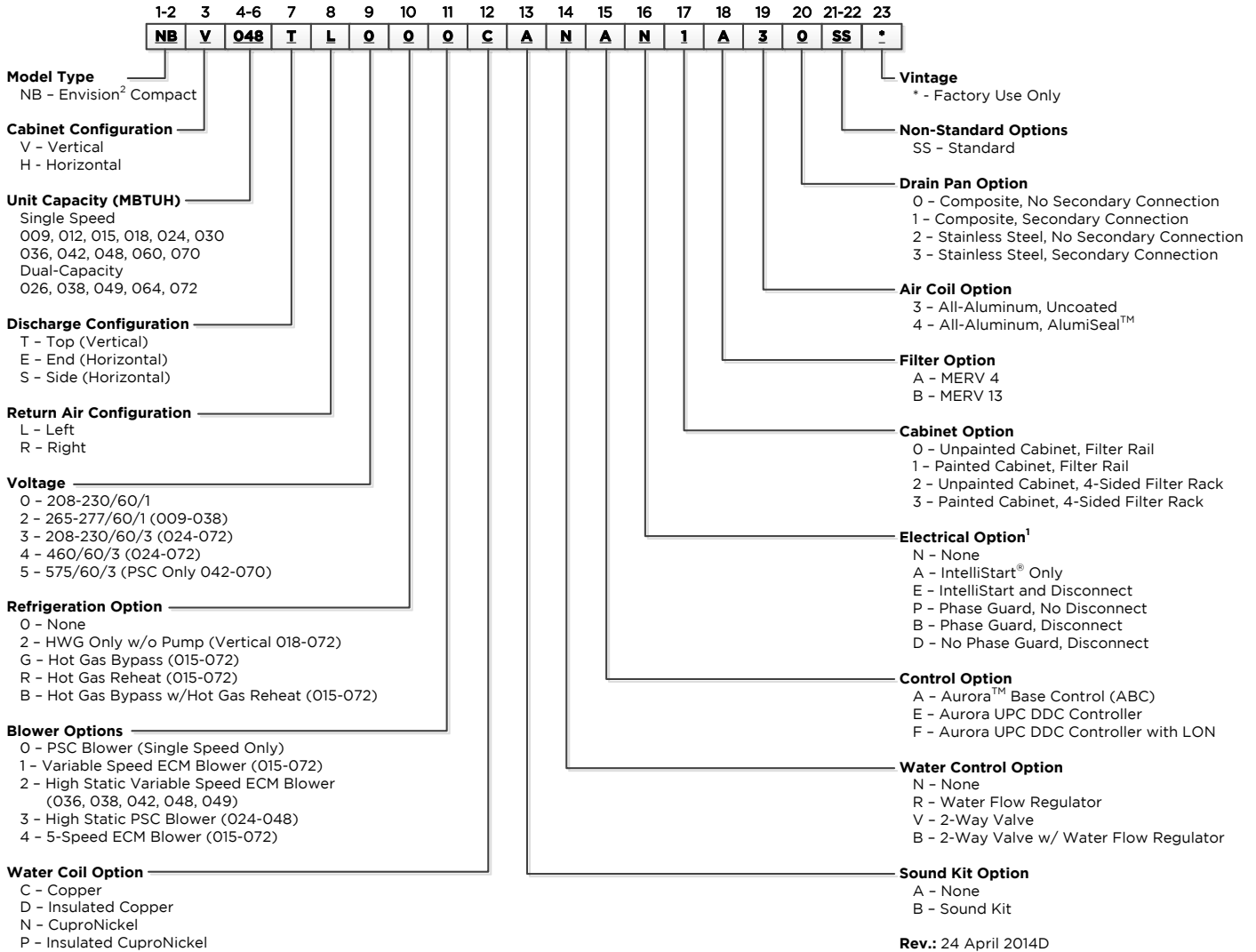

Note:
1 - Phase Guard Only Available on 208-230/60/3, 460/60/3, and 575/60/3

AHRI Data

PSC Motors

ARI/ASHRAE/ISO 13256-1
English (IP) Units

Model	Capacity Modulation	Flow Rate		Water Loop Heat Pump				Ground Water Heat Pump				Ground Loop Heat Pump			
				Cooling EWT 86°F		Heating EWT 68°F		Cooling EWT 59°F		Heating EWT 50°F		Cooling Brine Full Load 77°F Part Load 68°F		Heating Brine Full Load 32°F Part Load 41°F	
		gpm	cfm	Capacity Btu/h	EER Btuh/W	Capacity Btu/h	COP	Capacity Btu/h	EER Btuh/W	Capacity Btu/h	COP	Capacity Btu/h	EER Btuh/W	Capacity Btu/h	COP
009	Single	3.0	350	9,600	14.5	13,200	5.2	10,800	22.2	10,600	4.4	9,800	16.7	7,800	3.4
012	Single	3.5	400	12,300	15.7	14,800	5.1	14,500	25.5	12,300	4.5	13,000	18.0	9,600	3.7
015	Single	4.0	500	14,400	15.9	18,500	5.1	16,700	26.0	15,500	4.5	15,000	18.0	12,000	3.8
018	Single	5.0	600	18,000	15.6	23,000	5.1	21,000	25.5	19,000	4.4	18,500	18.0	14,700	3.8
024	Single	8.0	850	24,800	16.2	29,600	5.0	28,100	24.0	23,900	4.3	26,000	19.2	18,900	3.7
030	Single	8.0	900	27,600	18.2	30,600	5.4	30,800	27.1	24,400	4.7	29,200	21.1	19,800	3.8
036	Single	9.0	1200	34,100	17.6	34,200	5.6	36,300	25.7	28,200	4.7	34,600	19.6	24,100	4.0
042	Single	11.0	1300	40,100	16.6	42,800	5.1	44,600	24.5	34,900	4.3	41,600	18.6	27,500	3.7
048	Single	12.0	1500	46,400	15.5	53,100	4.9	51,600	22.5	43,400	4.2	48,900	17.3	35,000	3.6
060	Single	15.0	1800	61,300	15.4	69,000	5.0	68,700	23.2	55,100	4.4	65,500	18.2	43,200	3.7
070	Single	18.0	2000	67,000	14.5	81,800	4.6	75,900	21.6	66,100	4.0	70,600	17.0	52,000	3.4

Cooling capacities based upon 80.6°F DB, 66.2°F WB entering air temperature
Heating capacities based upon 68°F DB, 59°F WB entering air temperature
All ratings based upon 208V operation 3/16/12

Variable Speed ECM and 5-Speed ECM Motors

AHRI/ASHRAE/ISO 13256-1
English (IP) Units

Model	Capacity Modulation	Flow Rate		Water Loop Heat Pump				Ground Water Heat Pump				Ground Loop Heat Pump			
				Cooling EWT 86°F		Heating EWT 68°F		Cooling EWT 59°F		Heating EWT 50°F		Cooling Brine Full Load 77°F Part Load 68°F		Heating Brine Full Load 32°F Part Load 41°F	
		gpm	cfm	Capacity Btu/h	EER Btuh/W	Capacity Btu/h	COP	Capacity Btu/h	EER Btuh/W	Capacity Btu/h	COP	Capacity Btu/h	EER Btuh/W	Capacity Btu/h	COP
015	Single	4.0	500	14,400	16.5	18,500	5.3	16,700	27.0	15,500	4.7	15,000	18.8	12,000	4.0
018	Single	5.0	600	18,000	16.5	23,000	5.3	21,000	26.8	19,000	4.7	18,500	19.0	14,700	4.1
024	Single	8.0	800	24,800	17.0	29,600	5.3	28,100	27.5	23,900	4.6	26,000	19.6	18,900	3.8
030	Single	8.0	900	27,800	19.2	30,600	5.7	31,200	29.5	24,400	4.8	29,400	21.9	20,000	4.0
036	Single	9.0	1200	34,900	21.6	34,200	6.0	38,000	30.1	28,200	5.1	35,400	22.4	24,100	4.4
042	Single	11.0	1300	40,800	20.0	42,800	5.7	46,200	29.5	35,000	4.9	42,000	21.8	27,500	4.2
048	Single	12.0	1500	47,300	18.5	53,100	5.4	53,000	26.1	43,400	4.7	49,300	20.1	35,000	3.9
060	Single	15.0	1800	61,300	16.6	69,000	5.3	69,000	24.7	57,000	4.7	65,500	19.2	45,000	4.0
070	Single	18.0	2000	67,000	15.4	81,800	5.0	77,400	23.8	67,000	4.4	70,600	18.0	52,500	3.7
026	Full	8.0	950	26,000	17.3	30,300	5.5	29,000	24.0	25,100	5.0	27,700	20.4	19,500	4.3
	Part	7.0	750	20,000	19.5	22,300	6.4	22,600	32.7	18,300	5.3	22,000	27.9	16,300	4.8
038	Full	9.0	1300	39,000	18.0	40,300	5.4	39,400	24.1	33,600	4.8	40,200	21.0	26,700	4.1
	Part	8.0	1150	28,500	20.3	29,100	6.3	31,500	35.4	24,000	5.1	30,100	30.0	22,000	4.8
049	Full	12.0	1600	50,300	17.1	56,100	5.2	56,200	24.5	46,300	4.6	52,000	20.0	37,400	4.0
	Part	11.0	1400	37,200	19.2	39,800	5.8	41,500	33.0	32,300	4.7	40,600	28.5	30,000	4.6
064	Full	16.0	1800	62,000	16.3	70,600	5.2	70,100	23.9	58,000	4.7	65,100	18.7	47,100	4.0
	Part	14.0	1500	45,000	18.0	50,100	5.8	51,500	29.9	41,300	5.0	50,000	25.9	37,000	4.4
072	Full	18.0	2000	69,000	15.0	81,900	4.8	78,500	22.0	67,500	4.3	71,600	17.0	54,200	3.7
	Part	16.0	1500	52,800	16.0	61,400	5.2	61,000	27.0	49,400	4.4	59,000	23.4	45,000	4.1

Cooling capacities based upon 80.6°F DB, 66.2°F WB entering air temperature
Heating capacities based upon 68°F DB, 59°F WB entering air temperature
All ratings based upon 208V operation 3/16/12



All Envision² Compact product is safety listed under UL1995 thru ETL and performance listed with AHRI in accordance with standard 13256-1.

AHRI Data cont.

The performance standard AHRI/ASHRAE/ISO 13256-1 became effective January 1, 2000 and replaces AHRI Standards 320, 325, and 330. This new standard has three major categories: Water Loop (comparable to ARI 320), Ground Water (ARI 325), and Ground Loop (ARI 330). Although these standards are similar there are some differences:

Unit of Measure: The Cooling COP

The cooling efficiency is measured in EER (US version measured in Btu/h per Watt. The Metric version is measured in a cooling COP (Watt per Watt) similar to the traditional COP measurement.

Water Conditions Differences

Entering water temperatures have changed to reflect the centigrade temperature scale. For instance the water loop heating test is performed with 68°F (20°C) water rounded down from the old 70°F (21.1°C).

Air Conditions Differences

Entering air temperatures have also changed (rounded down) to reflect the centigrade temperature scale. For instance the cooling tests are performed with 80.6°F (27°C) dry bulb and 66.2°F (19°C) wet bulb entering air instead of the traditional 80°F (26.7°C) DB and 67°F (19.4°C) WB entering air temperatures. 80.6/66.2 data may be converted to 80/67 using the entering air correction table. This represents a significantly lower relative humidity than the old 80/67 of 50% and will result in lower latent capacities.

Pump Power Correction Calculation

Within each model, only one water flow rate is specified for all three groups and pumping Watts are calculated using the following formula. This additional power is added onto the existing power consumption.

- Pump power correction = (gpm x 0.0631) x (Press Drop x 2990) / 300

Where 'gpm' is waterflow in gpm and 'Press Drop' is the pressure drop through the unit heat exchanger at rated water flow in feet of head.

Blower Power Correction Calculation

Blower power is corrected to zero external static pressure using the following equation. The nominal airflow is rated at a specific external static pressure. This effectively reduces the power consumption of the unit and increases cooling capacity but decreases heating capacity. These Watts are significant enough in most cases to increase EER and COPs fairly dramatically over ARI 320, 325, and 330 ratings.

- Blower Power Correction = (cfm x 0.472) x (esp x 249) / 300

Where 'cfm' is airflow in cfm and 'esp' is the external static pressure at rated airflow in inches of water gauge.

ISO Capacity and Efficiency Calculations

The following equations illustrate cooling calculations:

- ISO Cooling Capacity = Cooling Capacity (Btu/h) + (Blower Power Correction (Watts) x 3.412)
- ISO EER Efficiency (W/W) = ISO Cooling Capacity (Btu/h) x 3.412 / [Power Input (Watts) - Blower Power Correction (Watts) + Pump Power Correction (Watt)]

The following equations illustrate heating calculations:

- ISO Heating Capacity = Heating Capacity (Btu/h) - (Blower Power Correction (Watts) x 3.412)
- ISO COP Efficiency (W/W) = ISO Heating Capacity (Btu/h) x 3.412 / [Power Input (Watts) - Blower Power Correction (Watts) + Pump Power Correction (Watt)]

Comparison of Test Conditions

	ARI 320	ISO/AHRI 13256-1 WLHP	ARI 325	ISO/AHRI 13256-1 GWHP	ARI 330	ISO/AHRI 13256-1 GLHP
Cooling						
Entering Air - DB/WB °F	80/67	80.6/66.2	80/67	80.6/66.2	80/67	80.6/66.2
Entering Water - °F	85	86	50/70	59	77	77
Fluid Flow Rate	*	**	**	**	**	**
Heating						
Entering Air - DB/WB °F	70	68	70	68	70	68
Entering Water - °F	70	68	50/70	50	32	32
Fluid Flow Rate	*	**	**	**	**	**

Note *: Flow rate is set by 10°F rise in standard cooling test Part load entering water conditions not shown.

Note **: Flow rate is specified by the manufacturer

WLHP = Water Loop Heat Pump; GWHP = Ground Water Heat Pump; GLHP = Ground Loop Heat Pump

Conversions:

Airflow (lps) = cfm x 0.472;

esp (Pascals) = esp (in wg) x 249;

Water Flow (lps) = gpm x 0.0631;

Press Drop (Pascals) = Press Drop (ft hd) x 2990

The Envision² Compact

WaterFurnace is proud to announce the Envision² Compact that boasts premium efficiency in a cabinet footprint that rivals lower efficiency commercial water source heat pumps. The Envision² Compact comes with single-stage compressors or two-stage Copeland UltraTech™ scrolls for added comfort and efficiency. Other advantages of specifying this premium product is the broad range of factory installed features such as hot gas reheat, internal 2-way valves, electrical disconnects, and many other valuable features that make this product stand in a class of its own.

Envision² Compact Highlights

- Capacities ranging from 009-072 MBtu/h output
- Complete commercial voltage selection of 208-230V/60Hz/1ph, 265/60/1, 208-230/60/3, and 575/60/3
- Industry leading quality through engineering and manufacturing using quality components
 - Premium Efficiency with rotary compressors for model sizes 009-018
 - Premium Efficiency with single stage scroll compressors for model sizes 024-070
 - Premium Efficiency with two-stage Copeland UltraTech™ scroll compressors for model sizes 026-072
 - Premium Efficiency 3 speed PSC, 5-speed ECM, or optional variable speed ECM blower motors
- Premium efficiency performance for maximizing LEED points
 - With PSC Blower Motor Up to 18.2 EER and 5.6 COP (ISO/AHRI 13256-1-WLHP)
 - With Variable Speed ECM Blower Motor (full load) Up to 21.6 EER and 6.0 COP (ISO/AHRI 13256-1-WLHP)
 - With Variable Speed ECM Blower Motor (part load) Up to 20.3 EER and 6.4 COP (ISO/AHRI 13256-1-WLHP)
- Premium performance in a cabinet footprint of less efficient product
 - Horizontal cabinets 12 in. to 24 in. less in length versus models with comparable performance
 - 17 in. high 009-012
 - 19 in. high 015-030
 - 21 in. high 036-072
- Dedicated 460V 5-speed ECM does not require use of neutral!
- All-Aluminum air coils are not susceptible to Formicary Corrosion.
- Wide array of standard factory installed options including:
 - Configurations - horizontal left and right return, end or side discharge (field switchable); vertical left and right return
 - 3 speed PSC, 5-speed ECM, or variable speed ECM blower motor with high static options
 - Internal hot water generator coil (vertical only)
 - Copper or cupronickel heat exchanger and optional low temperature insulation
 - Hot Gas reheat and/or bypass
 - Corrosion-proof composite or stainless steel drain pan; including internally mounted secondary drain connection option
 - Filter options: standard 1 in. MERV 4 or optional 2 in. MERV 13 factory installed with either filter rails or optional deluxe filter rack both field switchable between 1 in. and 2 in.
 - Aurora Base Control or with Aurora UPC with N2, BACnet, or optional LonWorks card
 - Factory mounted internal water valve and/or flow regulator for variable speed pumping systems saving on installation costs
 - Other Options: Sound Kit, coated air coil, phase guard, factory mounted power disconnect, painted cabinet



Vertical Envision² Compact

Models NBV009-070 (3/4-6 ton) Single Speed
 Models NBV026-072 (2-6 ton) Dual Capacity

Horizontal Envision² Compact

Models NBH009-070 (3/4-6 ton) Single Speed
 Models NBH026-072 (2-6 ton) Dual Capacity

The Envision² Compact cont.

Product Features: Vertical Cabinet

Vertical units are designed for high efficiency, maximum flexibility, and primary servicing from the front.

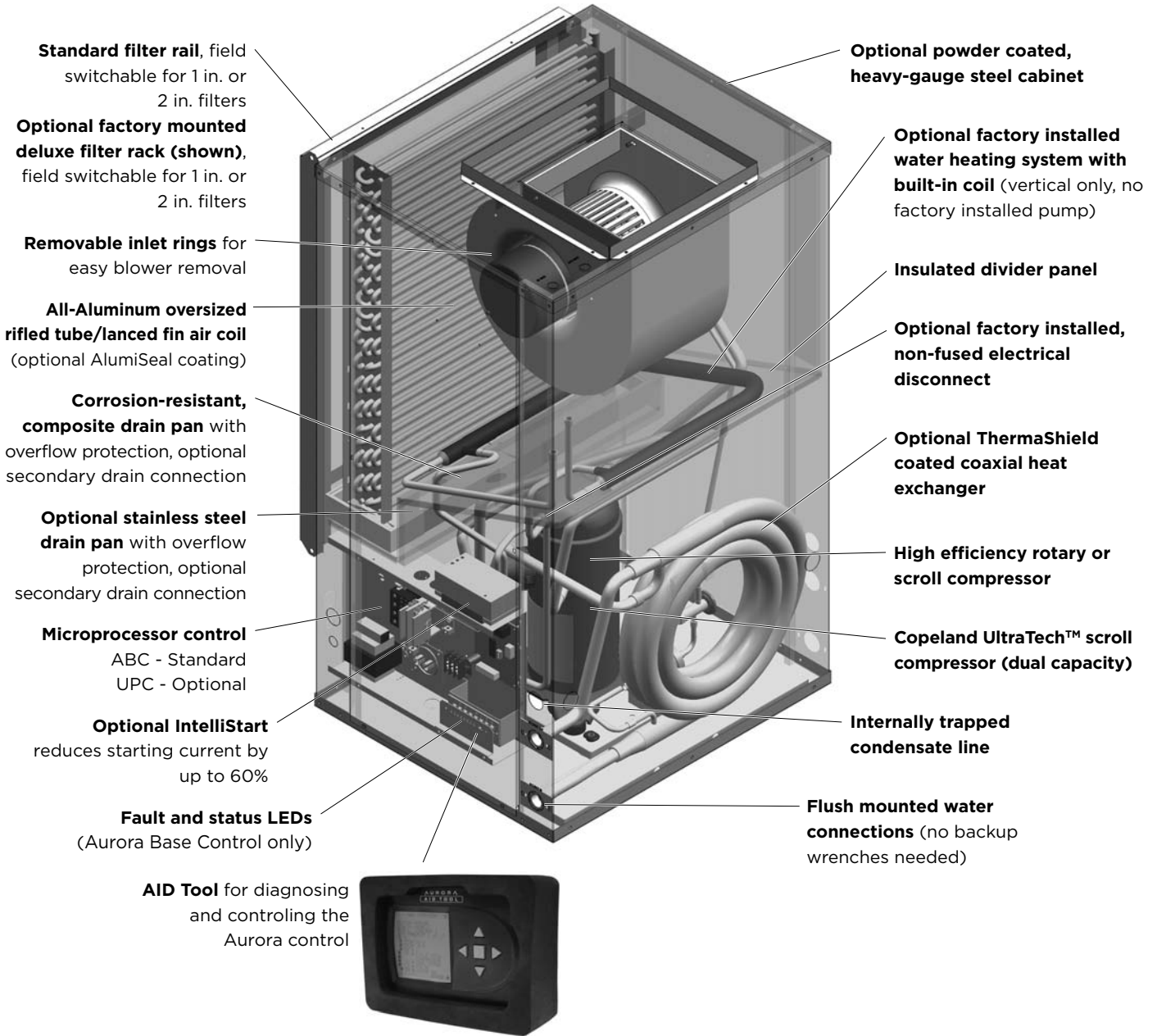

A true left and right return option is available.

The Envision² Compact cont.

Product Features: Horizontal Cabinet

Horizontal units are available in seven cabinet sizes. The cabinets are designed for high efficiency, maximum flexibility, and primary servicing from the front.

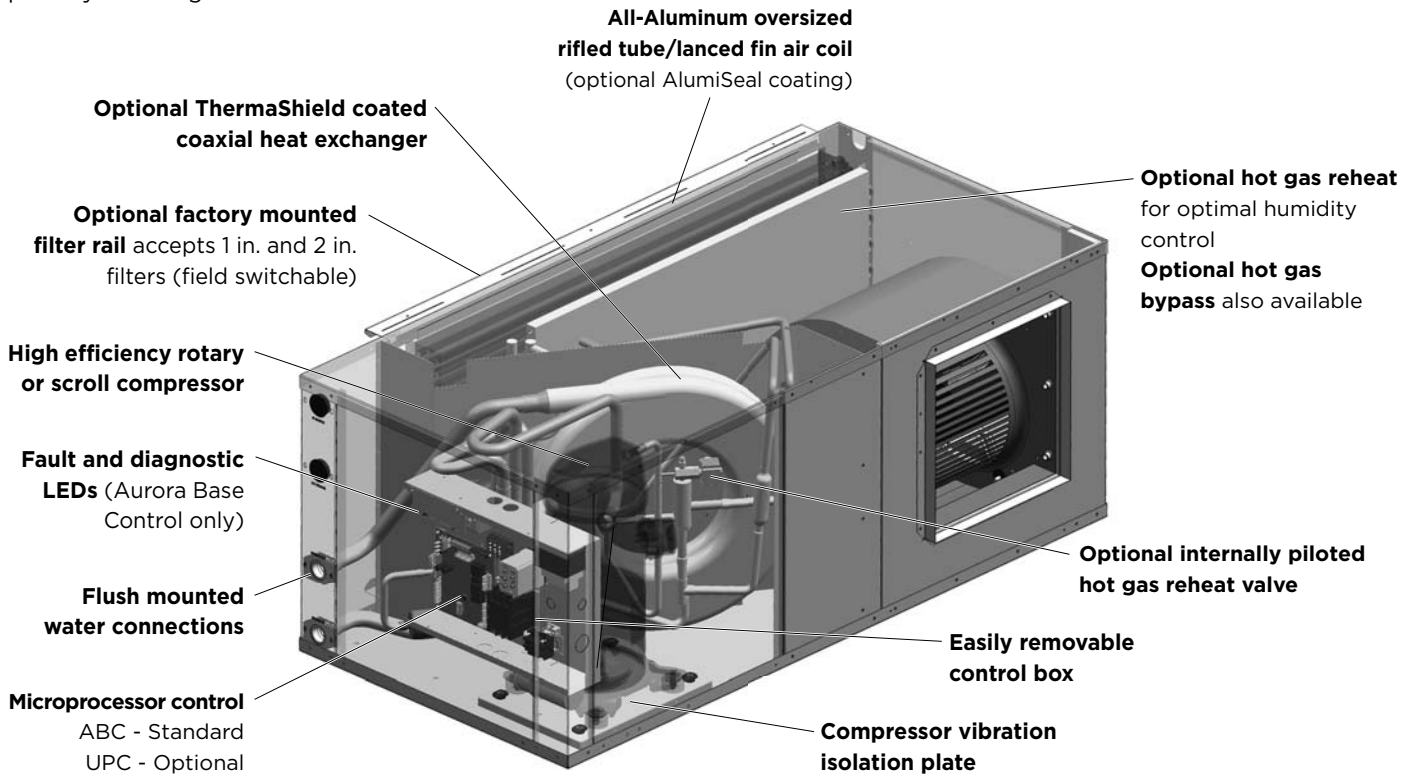

Four blower deck options are available. Factory or field conversion option of end or side discharge using switchable access panels and a factory only option of true left or right return air coil.

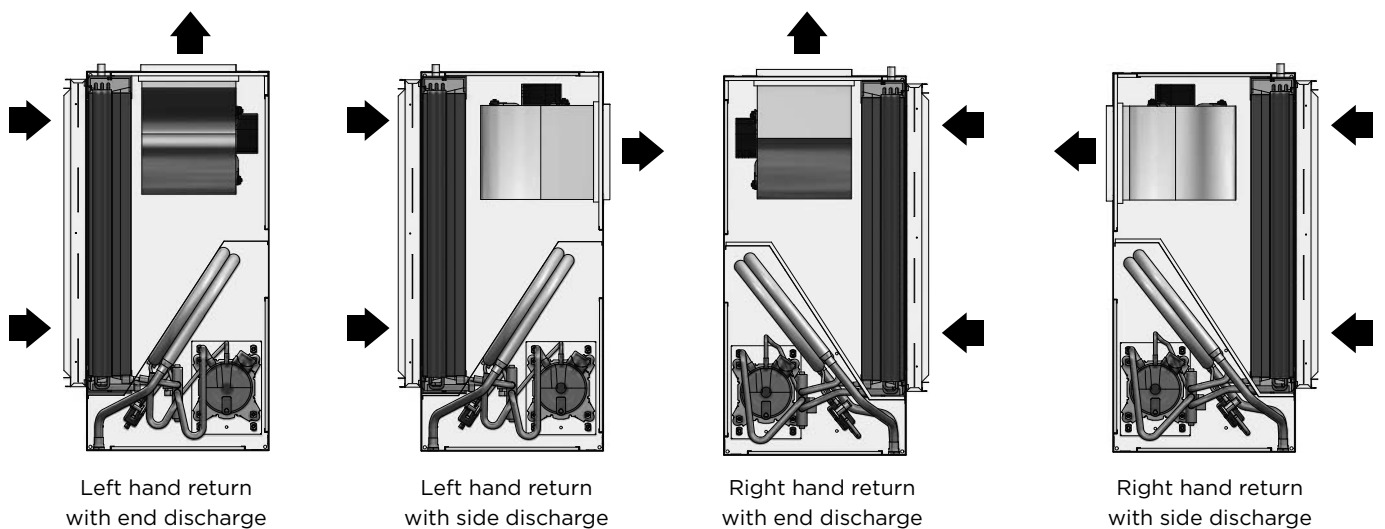

The Envision² Compact cont.

Flexible Product with Several Standard Options

- Compact cabinet design, vertical and horizontal with true left and right return configurations
- Horizontal end and side discharge with vertical top discharge air configurations
- Capacities of 9,000 through 70,000 Btu/h for single speed models
- Capacities of 26,000 through 72,000 Btu/h for dual capacity models
- All commercial voltages including 208-230/60/1, 265-277/60/1, 208-230/60/3, 460/60/3, and 575/60/3.
- Hot water generation (hot water generator - vertical only)
- 3 speed PSC, 5-speed ECM, or optional variable speed ECM blower motors (high static options available)
- All-Aluminum air coils with optional AlumiSeal coating
- Copper or cupronickel heat exchangers
- Extended range insulation option
- Super Quiet Sound Package, including multi-density compressor blanket
- Quiet rotary or scroll compressors in all models
- 2-dimension refrigerant piping vibration loops to isolate the compressor
- Double isolated compressor mounting utilizing eight durometer selected rubber grommets
- Heavy gauge cabinet and vibration isolating hanger brackets
- Hot Gas Bypass and Reheat (015-072)
- Internally mounted water flow regulator and/or water solenoid valve for variable speed pumping systems
- Standard Aurora Base Control or UPC DCC Control with standard N2, ModBus, BACnet, or optional LonWorks card
- Phase guard with optional 'dial' disconnect
- Optional painted cabinet
- Polymer composite drain pan or stainless steel drain pan with optional secondary drain connection
- 1 in. MERV 4 or 2 in. MERV 13 filters
- 3rd party sound tested to AHRI 260

Other options are available by special request through WaterFurnace Commercial Sales.

Premium Efficiency

The Envision² Compact is a premium efficiency water source heat pump in a compact vertical and horizontal cabinet. The product features highly efficient and reliable single capacity rotary or scroll compressors or dual capacity Copeland UltraTech scroll compressors, mated with large blowers. These blowers are driven by efficient 3 speed PSC blower motors, 5-speed ECM blower motors, or highly efficient variable speed ECM blower motors.

Super Quiet Option

An optional Super Quiet Sound Package is also available for a modest cost and features multi-density laminate lined compressor blanket designed to completely surround the compressor and suppress low frequency noise.



Indoor Air Quality (IAQ)

All Envision² Compact features several IAQ benefits:

- Corrosion-free composite double-sloped drain pan to eliminate standing water and prevent bacterial growth
- A washable surface on insulation in all air handler compartments to allow cleanability and inhibit bacteria growth. Optional non-fibrous closed cell insulation is also available for more sensitive applications.
- Open filter rail comes standard for non-ducted return applications. Filter rail is field switchable from 1 in. to 2 in. [2.54 to 5.1 cm] for more filter options.
- Optional factory mounted, four sided, deluxe filter rack that is field switchable from 1 in. to 2 in. [2.54 to 5.1 cm] is available for ducted return applications.
- Standard supplied filter is a pleated MERV 4, 1 in. [2.54 cm]. An optional low static high efficiency 2 in. [5.1 cm] MERV 13, for LEED certification points, is also available.





The Envision² Compact cont.

Aurora Base Control

The Aurora Base Control (ABC) System is a complete residential and commercial comfort system that brings all aspects of the HVAC system into one cohesive module network. Aurora uses the Modbus communication protocol to communicate between modules. Each module contains the logic to control all features that are connected to the module. The Aurora Base Control (ABC) has two Modbus channels. The first channel is configured as a master for connecting to devices such as a communicating thermostat, expansion board, or other slave devices. The second channel is configured as a slave for connecting the Aurora Interface Diagnostic (AID) Tool.

Aurora Unitary Protocol Converter (UPC)

The optional Aurora UPC control provides unparalleled capability in several areas including energy, refrigerant, and performance monitoring, humidity, energy management, and service diagnostics, and then communicates it all thru standard DDC protocols like N2, Lon and BACnet MS/TP. The most unique feature is integration of the Aurora Base Control and UPC into the Envision² Compact as an integrated heat Pump and DDC controller providing both a cost advantage and providing features not typically found on WSHP controls. This integration allows heat pump monitoring sensors, status and service diagnosis faults to be communicated thru the DDC direct to the building automation system (BAS), giving building supervisors detailed and accurate information on every piece of equipment without removing an access panel!

Control	General Description	Application	Display/Interface	Protocol
Aurora Base Control 	The ABC microprocessor provides all the features necessary to operate today's standard WSHPs that utilize dual capacity compressors and variable speed ECM/5 speed ECM blower motors with hot gas reheat. This control can communicate to a handheld diagnostic tool to help the installing contractor or service technician with equipment setup and service. By utilizing Modbus RTU communication protocol, the ABC board can communicate with additional devices on the Aurora network	Used for residential and commercial applications that use single or dual capacity compressors with PSC, 5-speed ECM, or variable speed ECM blower motors. This base control can also communicate to the AID Tool to display faults, inputs/outputs, and software revision. Commercial features such as hot gas reheat, slow opening water valve, and random start are also capable with the ABC board.	Optional AID tool can be used for field service.	Standalone
Aurora Base Control w/UPC BACnet or N2 	The Aurora Unitary Protocol Converter (UPC) is an integrated solution and communicates directly with the Aurora Heat Pump Controls and allows access/control of a variety of internal Aurora heat pump operations such as sensors, relay operation, faults and other information. In turn, the UPC then converts internal Aurora Modbus protocol to BACnet MS/TP, or N2 protocols and communicates to the BAS system. This provides the great benefit of complete control integration and a myriad of information available to the BAS from the heat pump control. Plus it also allows individual unit configuration such as ECM fan speeds or freeze protection setting directly over the BAS without the need for access to the actual heat pump.	The Aurora UPC is implemented with the Aurora Base Controller (ABC) heat pump control into our latest water source heat pumps. All Internal Aurora points are accessible to the UPC via firmware providing an integrated solution. All zone temperatures and zone sensors are connected to the UPC on an RNet bus, simplifying hook up at the unit. RNet sensors can include a combination of zone temperature and humidity, CO2, and VOC sensors. The UPC includes built-in support for a custom configurable keypad/display unit.	Optional Equipment Touch display	BACnet MS/TP or N2 Open (DIP selectable)
Aurora Base Control w/UPC LonWorks 	The Aurora Unitary Protocol Converter (UPC) is an integrated solution and communicates directly with the Aurora Heat Pump Controls and allows access/control of a variety of internal Aurora heat pump operations such as sensors, relay operation, faults and other information. In turn, the UPC then converts internal Aurora Modbus protocol to LONWorks protocol and communicates to the BAS system.	The Aurora UPC is implemented with the Aurora Base Controller (ABC) heat pump control into our latest water source heat pumps. All Internal Aurora points are accessible to the UPC via firmware providing an integrated solution. All zone temperatures and zone sensors are connected to the UPC on an RNet bus, simplifying hook up at the unit. RNet sensors can include a combination of zone temperature and humidity, CO2, and VOC sensors. The UPC includes built-in support for a custom configurable keypad/display unit.	Optional Equipment Touch display	LonWorks
AXB Expansion Board (Future Availability)	Aurora Advanced Control adds the Aurora AXB expansion board and provides added I/O and standard features. AXB can be added to any of the above packages to enhance the I/O of the controls.	<ul style="list-style-type: none"> • Refrigeration Monitoring - provides Suction and discharge pressure, Suction, liquid line temps and superheat and subcooling. • Performance Monitoring - provides entering and leaving loop water temperatures, loop flow rate as well as heat of extraction or rejection rate into the loop. • Energy Monitoring - provides real-time power measurement (Watt) of compressor, fan, auxiliary heat and zone pump. • Plus many more I/O options 		

The Envision² Compact cont.

Internally Mounted Solenoid Valve Option

When variable speed circulating pump systems are designed, low pressure drop (high Cv) solenoid valves are specified at each unit to vary the pump according to flow required. It is important that these valves be low pressure drop to avoid unwanted pump watts. This option factory installs this valve inside the unit.

Secondary Drain Connection Option

Some local building authority's interpretation of codes require more condensate overflow protection than standard microprocessor based condensate sensors offer. In these areas a full secondary drain pan might be required causing both increased cost and unit service access issues. In many of these cases a secondary drain connection option can be added to the unit to pass this local interpretation of condensate drain redundancy. This option adds a second PVC drain connection to the drain pan at a higher level.



Hot Gas Bypass/Reheat

The hot gas bypass option is designed to limit the minimum evaporating pressure in the cooling mode to prevent the air coil from icing. Hot gas reheat option provides consistent comfort by removing moisture from the air without over cooling the space. These options are available together or standalone.

Phase Guard Monitor

Factory mounted phase guard device is available to protect the compressor against loss of phase and reverse rotation.

Electrical Disconnect

An optional factory mounted, internally wired disconnect is available to avoid scheduling problems with the electrical contractor. Other features include:

- Non-fused, 'dial' type switch with "on/off" position
- Compact design
- "Lockout/Tagout" feature to keep the unit "off" during service



Factory Quality

- All refrigerant brazing is performed in a nitrogen environment.
- Computer controlled deep vacuum and refrigerant charging system.
- All joints are leak detected for maximum leak rate of less than 1/4 oz. per year.
- Computer bar code equipped assembly line ensures all components are correct.
- All units are computer run-tested with water to verify both function and performance.



Inside the Envision² Compact

Refrigerant

Envision² Compact products all feature zero ozone depletion and low global warming potential refrigerant R-410A.

Cabinet

All units are constructed of corrosion resistant galvanized sheet metal with optional white polyester powder coat paint rated for more than 1,000 hours of salt spray. One large lift-out access panel provides access to the compressor and air handler section to allow servicing of blower motor, blower, and drain pan. Refrigerant circuit is designed to allow primary serviceability from the front. Seven (7) horizontal and six (6) vertical cabinets are provided for application

flexibility. The blower motor and blower can be completely serviced or replaced without removal of the unit. Service of the blower and blower motor is made easier via the removable orifice ring on the housing.

Flexible configurations include four (4) blower deck options for horizontals and a true left and right return on both horizontal and vertical.

Filter Rack

All units come standard with an open filter rail, for use in open return applications, or an optional deluxe filter rack/duct collar for use with ducted returns. Both filter options

Inside the Envision² Compact cont.

are field switchable between 1 in. [2.54 cm] and 2 in. [5.1 cm] thick filters for filter flexibility. A MERV 4, 1 in. [2.54 cm] is standard with an optional 2 in. [5.1 cm] MERV 13 for LEED certification points and high efficiency filtration.



Electrical Box

Unit controls feature quick connect wiring harnesses for easy servicing. Separate knockouts for low voltage and two sides of the electrical corner post for easy access to the control box. Large transformer (75VA with ABC with reheat and 50VA with ABC without reheat) assures adequate controls power for accessories.

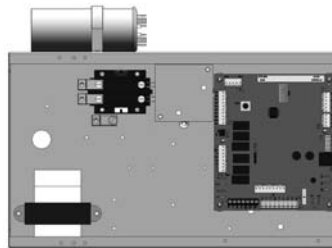

Water Connections

Flush mount FPT water connection fittings allow one wrench leak-free connections and do not require a backup wrench.



Horizontal Hanger Kits

Each horizontal unit includes a hanger kit to meet seismic specification requirements while still allowing filter access.

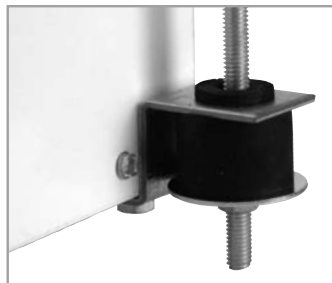

Drain Pan

All condensate connections are PVC glue for economical corrosion free connections. Bacteria resistant composite drain pan is sloped to promote complete drainage and will never rust or corrode. Complete drainage helps to inhibit

bacterial or microbial growth. Vertical units feature an internally trapped condensate line using clear PVC hose for easy inspection and reduced installation cost. Optional factory installed stainless steel drain pans are also available.



Compressors

High efficiency R-410A rotary or scroll compressors are used on every model. Rotary or scrolls provide both the highest efficiency available and great reliability. Single speed scroll and Copeland UltraTech dual capacity scroll models are available in commercial voltages.



Compressor Dual Isolation Mounting

Double isolated compressor mounting utilizing eight durometer selected rubber grommets. This isolation greatly reduces the primary noise frequency range of 100-300 Hz.



Air Handler Insulation

Washable air handler insulation surface provides cleanability to further enhance IAQ.



Thermostatic Expansion Valve

All Envision² Compact models utilize a balanced port bidirectional thermostatic expansion valve (TXV) for refrigerant metering. This allows precise refrigerant flow in a wide range of entering water variation (20 to 120°F [-7 to 49°C]) found in geothermal systems. The TXV is located in the compressor compartment for easy access.



Inside the Envision² Compact cont.

Water-to-Refrigerant Coaxial Heat Exchanger Coil

Large oversized coaxial refrigerant to water heat exchangers provide unparalleled efficiency. The coaxes are designed for low pressure drop and low flow rates. All coaxes are pressure rated to 450 psi water side and 600 psi on the refrigerant side. Optional ThermaShield coating is available on the water-to-refrigerant heat exchanger to prevent condensation in low temperature loop operation.



Service Connections and Serviceability

Two Schrader service ports are provided in every unit. The suction side and discharge side ports are for field charging and servicing access. All valves are 7/16 in. SAE connections. All water and electrical connections are made from the front of the unit. Unit is designed for front access serviceability.



4-Way Reversing Valve

Envision² Compact units feature a reliable all-brass pilot operated refrigerant reversing valve. The reversing valve operation is limited to change of mode by the control to enhance reliability.



NEW!: All-Aluminum Air Coil

Beginning in Spring of 2014, all models in the Envision² Compact line began shipping with all-aluminum air coils. WaterFurnace is the first manufacturer to offer an all-aluminum round-tube-and-fin air coil in a packaged water source heat pump. These air coils are constructed of lanced fin and rifled tube aluminum that is not susceptible to formicary corrosion. For additional condensate runoff and meeting project specifications, an optional AlumiSeal e-coating is available.

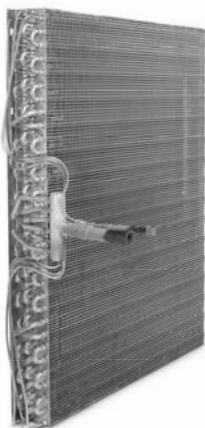

Blower Motor and Housing

High efficiency low rpm galvanized direct drive blower featuring 3 speed permanently split capacitor (PSC) motor, 5-speed ECM motor, and optional variable speed ECM blower motor. The variable speed ECM motor is controlled

directly through the unit's Aurora Base Control. The lower rpm blower also reduces air noise. All PSC and 5-speed ECM motors have speed selection terminal strip on the motor for easy speed change. All motors are vibration isolated to reduce noise. High static options are available in some models for both PSC and variable speed ECM motor versions. Horizontal units can be field converted from end to side discharge as well.

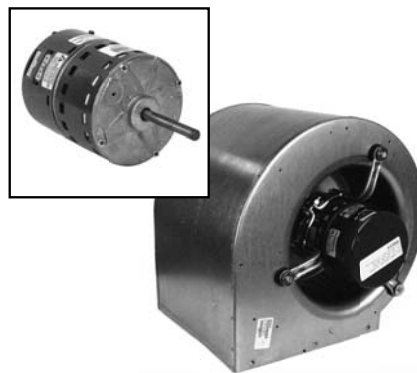

NOTE: 460V 5-speed ECM blower motor does not require a neutral wire.

5-Speed ECM Constant Torque Motors

The 5-speed ECM is a 'Constant Torque' ECM motor and delivers air flow similar to a PSC but operates as efficiently as a variable speed ECM motor. Because it is an ECM motor, the 5-speed ECM can ramp slowly up or down like the variable speed ECM motor. There are 5 possible speed taps available on the 5-speed ECM motor with #1 being the lowest airflow and #5 being the highest airflow. These speed selections are preset at the time of manufacture and are easily changed in the field if necessary.

5-Speed ECM Benefits:

- High efficiency
- Soft start
- 5 speeds with up to 4 speeds on-line
- Built in logic allows air flow to change with G, Y1, Y2, and W signals
- Super efficient low airflow continuous blower setting (G)

IntelliStart[®]

The optional IntelliStart single phase soft starter will reduce the normal start current (LRA) by 60%. This allows the heat pump to go off-grid. Using IntelliStart also provides a substantial reduction in voltage sag, reduces startup noise, and improves the compressor's start behavior.

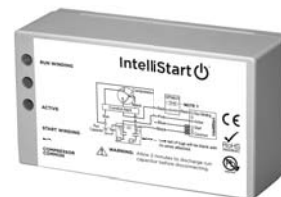

Controls - Aurora Base Control

Aurora 'Base' Control

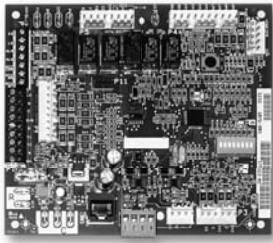

NOTE: Refer to the Aurora Base Control Application and Troubleshooting Guide and the Instruction Guide: Aurora Interface and Diagnostics (AID) Tool for additional information.

Control Features

Software ABC Standard Version 2.0

Single or Dual Capacity Compressors

Either single or dual capacity compressors can be operated.

Variable Speed ECM Blower Motor Option

A Variable Speed ECM blower motor can be driven directly using the onboard PWM output. Four blower speeds are available based upon the G, Y1, Y2, and W input signals to the board. The blower speeds can be changed either by the ECM manual configurations mode method or by using the Aurora AID Tool directly. All four blower speeds can be set to the same speed if desired.

5-Speed ECM Blower Motor Option

A 5-Speed ECM blower motor will be driven directly using the thermostat connections. Any of the G, Y1, or Y2/W signals can drive any of the 5 available pre-programmed blower speeds on the motor. All 5 Series "G" vintage units will be wired this way at the factory.

Other Control Features

- Random start at power up
- Anti-short cycle protection
- High and low pressure cutouts
- Loss of charge
- Water coil freeze detection
- Air coil freeze detection
- Over/under voltage protection
- Condensate overflow sensor
- Load shed
- Dehumidification (where applicable)
- Emergency shutdown
- Hot gas reheat operation (where applicable)
- Diagnostic LED
- Test mode push button switch
- Two auxiliary electric heat outputs
- Alarm output
- Accessory output with N.O. and N.C.
- Modbus communication (master)
- Modbus communication (slave)

Field Selectable Options via Hardware

DIP Switch (SW1) – Test/Configuration Button (See SW1 Operation Table)

Test Mode

The control is placed in the test mode by holding the push button switch SW1 for 2 - 5 seconds. In test mode most of the control timings will be shortened by a factor of sixteen (16). LED3 (green) will flash at 1 second on and 1 second off. Additionally, when entering test mode LED1 (red) will flash the last lockout one time. Test mode will automatically time out after 30 minutes. Test mode can be exited by pressing and holding the SW1 button for 2 to 5 seconds or by cycling the power. **NOTE:** Test mode will automatically be exited after 30 minutes.

ECM Configuration Mode

The control is placed in the ECM configuration mode by holding the pushbutton switch SW1 for 5 to 10 seconds, the high, low, and "G" ECM speeds can be selected by following the LED display lights. LED2 (yellow) will fast flash when entering the ECM configuration. When setting "G" speed LED3 (green) will be continuously lit, for low speed LED1 (red) will be continuously lit, and for high speed both LED3 (green) and LED1 (red) will be continuously lit. During the ECM configuration mode LED2 (yellow) will flash each of the 12 possible blower speeds 3 times. When the desired speed is flashed press SW1, LED2 will fast flash until SW1 is released. "G" speed has now been selected. Next select low speed, and high speed blower selections following the same process above. After third selection has been made, the control will exit the ECM configuration mode. Aux fan speed will remain at default or current setting and requires the AID Tool for adjustment.

Reset Configuration Mode

The control is placed in reset configuration mode by holding the push button switch SW1 for 50 to 60 seconds. This will reset all configuration settings and the EEPROM back to the factory default settings. LED3 (green) will turn off when entering reset configuration mode. Once LED3 (green) turns off, release SW1 and the control will reset.

DIP Switch (SW2)

- SW2-1** FP1 Selection – Low water coil temperature limit setting for freeze detection. On = 30°F; Off = 15°F.
- SW2-2** FP2 Selection – On = 30°F; Off = N/A
- SW2-3** RV – O/B - thermostat type. Heat pump thermostats with "O" output in cooling or "B" output in Heating can be selected. On = O; Off = B.
- SW2-4 and 2-5** Access Relay Operation (P2)

Access Relay Operation	SW2-4	SW2-5
Cycle with Blower	ON	ON
Cycle with Compressor	OFF	OFF
Water Valve Slow Opening	ON	OFF
Cycle with Comm. T-stat Hum Cmd	OFF	ON

Controls - Aurora Base Control cont.

Cycle with Blower - The accessory relay will cycle with the blower output.

Cycle with Compressor - The accessory relay will cycle with the compressor output.

Water Valve Slow Opening - The accessory relay will cycle and delay both the blower and compressor output for 90 seconds.

SW2-6 CC Operation - selection of single or dual capacity compressor. On = Single Stage; Off = Dual Capacity

SW2-7 Lockout and Alarm Outputs (P2) - selection of a continuous or pulsed output for both the LO and ALM Outputs. On = Continuous; Off = Pulsed

SW2-8 Future Use

Alarm Jumper Clip Selection

From the factory, ALM is connected to 24 VAC via JW2. By cutting JW2, ALM becomes a dry contact connected to ALG.

ECM Blower Speeds

The blower speeds can be changed either by using the ECM manual configurations mode method or by using the Aurora AID Tool directly (see Instruction Guide: Aurora Interface and Diagnostics (AID) Tool topic).

Field Selectable Options via Software

(Selectable via the Aurora AID Tool)

ECM Blower Speeds

An ECM blower motor can be driven directly using the onboard PWM output. Four blower speeds are available, based upon the "G", Y1 (low), Y2 (high), and Aux input signals to the board. The blower speeds can be changed either by the ECM manual configurations mode method (see ECM Configuration Mode topic) or by using the Aurora AID Tool directly. All four blower speeds can be set to the same speed if desired. Aux blower speed will remain at default or current setting and requires the AID Tool for adjustment.

Safety Features

The following safety features are provided to protect the compressor, heat exchangers, wiring and other components from damage caused by operation outside of design conditions.

Fuse - a 3 amp automotive type plug-in fuse provides protection against short circuit or overload conditions.

Anti-Short Cycle Protection - 4 minute anti-short cycle protection for the compressor.

Random Start - 5 to 80 second random start upon power up.

Fault Retry - in the fault condition, the control will stage off the outputs and then "try again" to satisfy the thermostat Y input call. Once the thermostat input calls are satisfied, the control will continue on as if no fault occurred. If 3 consecutive faults occur without satisfying the thermostat Y input call, then the control will go to Lockout mode.

Lockout - when locked out, the blower will operate continuously in "G" speed, and PSC blower motor output will remain on. The Alarm output (ALM) and Lockout output (L) will be turned on. The fault type identification display LED1 (Red) shall flash the fault code. To reset lockout conditions with SW2-8 On, thermostat inputs "Y1", "Y2", and "W" must be removed for at least 3 seconds. To reset lockout conditions with SW2-8 Off, thermostat inputs "Y1", "Y2", "W", and "DH" must be removed for at least 3 seconds. Lockout may also be reset by turning power off for at least 30 seconds or by enabling the emergency shutdown input for at least 3 seconds.

Lockout With Emergency Heat - if the control is locked out in the heating mode, and a Y2 or W input is received, the control will operate in the emergency heat mode while the compressor is locked out. The first emergency heat output will be energized 10 seconds after the W input is received, and the blower will shift to high speed. If the control remains locked out, and the W input is present, additional stage of emergency heat will stage on after 2 minutes. When the W input is removed, all of the emergency heat outputs will turn off, and the ECM blower will shift to "G" speed and PSC blower motor output will remain on.

High Pressure - fault is recognized when the Normally Closed High Pressure Switch, P4-9/10 opens, no matter how momentarily. The High Pressure Switch is electrically in series with the Compressor Contactor and serves as a hard-wired limit switch if an overpressure condition should occur.

Low Pressure - fault is recognized when the Normally Closed Low Pressure Switch, P4-7/8 is continuously open for 30 seconds. Closure of the LPS any time during the 30 second recognition time restarts the 30 second continuous open requirement. A continuously open LPS shall not be recognized during the 2 minute startup bypass time.

Loss of Charge - fault is recognized when the Normally Closed Low Pressure Switch, P4-7/8 is open prior to the compressor starting.

Condensate Overflow - fault is recognized when the impedance between this line and 24 VAC common or chassis ground drops below 100K ohms for 30 seconds continuously.

Freeze Detection (Coax) - set points shall be either 30°F or 15°F. When the thermistor temperature drops below the selected set point, the control shall begin counting down the 30 seconds delay. If the thermistor value rises above the selected set point, then the count should reset. The resistance value must remain below the selected set point for the entire length of the appropriate delay to be recognized as a fault. This fault will be ignored for the initial 2 minutes of the compressor run time.

Freeze Detection (Air Coil) - uses the FP2 input to protect against ice formation on the air coil. The FP2 input will operate exactly like FP1 except that the set point is 30 degrees and is not field adjustable.

Controls - Aurora Base Control cont.

Over/Under Voltage Shutdown - An over/under voltage condition exists when the control voltage is outside the range of 18 VAC to 30 VAC. If the over/under voltage shutdown lasts for 15 minutes, the lockout and alarm relay will be energized. Over/under voltage shutdown is self-resetting in that if the voltage comes back within range of 18 VAC to 30 VAC for at least 0.5 seconds, then normal operation is restored.

Operation Description

Power Up - The unit will not operate until all the inputs and safety controls are checked for normal conditions. The unit has a 5 to 80 second random start delay at power up. Then the compressor has a 4 minute anti-short cycle delay after the random start delay.

Standby In standby mode, Y1, Y2, W, DH, and G are not active. Input O may be active. The blower and compressor will be off.

Heating Operation

Heating, 1st Stage (Y1) - The blower is started on "G" speed immediately and the compressor is energized 10 seconds after the Y1 input is received. The ECM blower motor is switched to low speed 15 seconds after the Y1 input.

Heating, 2nd Stage (Y1, Y2) - The compressor will be staged to full capacity 20 seconds after Y2 input is received. The ECM blower will shift to high speed 15 seconds after the Y2 input is received.

Heating, 3rd Stage (Y1, Y2, W) - The hot water pump is de-energized and the first stage of electric heat is energized 10 seconds after the W command is received. If the demand continues the second stage of electric heat will be energized after 5 minutes.

Emergency Heat (W) - The blower will be started on "G" speed, 10 seconds later the first stage of electric heat will be turned on. 5 seconds after the first stage of electric heat is energized the blower will shift to Aux speed. If the emergency heat demand is not satisfied after 2 minutes the second electric heat stage will be energized.

Blower (G) - The blower will start immediately upon receiving a thermostat G command. If there are no other commands from the thermostat the ECM will run on "G" speed until the G command is removed. Regardless of blower input (G) from the thermostat, the blower will remain on for 30 seconds at the end of each heating cycle.

Cooling Operation

In all cooling operations, the reversing valve directly tracks the O input. Thus, anytime the O input is present, the reversing valve will be energized.

Cooling, 1st Stage (Y1, O) - The blower is started on "G" speed immediately and the compressor is energized 10 seconds after the Y1 input is received. The ECM blower motor is switched to low speed 15 seconds after the Y1 input.

Cooling, 2nd Stage (Y1, Y2, O) - The compressor will be staged to full capacity 20 seconds after Y2 input is received. The ECM blower will shift to high speed 15 seconds after the Y2 input is received.

Blower (G) - The blower will start immediately upon receiving a thermostat G command. If there are no other commands from the thermostat the ECM will run on "G" speed until the G command is removed. Regardless of blower input (G) from the thermostat, the blower will remain on for 30 seconds at the end of each heating, cooling, and emergency heat cycle.

Dehumidification (Y1, O, DH or Y1, Y2, O, DH) - When a DH command is received from the thermostat during a compressor call for cooling the ECM blower speed will be reduced by 15% to increase dehumidification.

Emergency Shutdown - Four (4) seconds after a valid ES input, P2-7 is present, all control outputs will be turned off and remain off until the emergency shutdown input is no longer present. The first time that the compressor is started after the control exits the emergency shutdown mode, there will be an anti-short cycle delay followed by a random start delay. Input must be tied to common to activate.

Continuous Blower Operation - The blower output will be energized any time the control has a G input present, unless the control has an emergency shutdown input present. The blower output will be turned off when G input is removed.

Load Shed - The LS input disables all outputs with the exception of the blower output. When the LS input has been cleared, the anti-short cycle timer and random start timer will be initiated. Input must be tied to common to activate.

Controls - Aurora Base Control cont.

Aurora 'Base' Control LED Displays

These three LEDs display the status, configuration, and fault codes for the control. These can also be read in plain English via the Aurora AID Tool.

Status LED (LED3, Green)

Description of Operation	Fault LED, Green
Normal Mode	ON
Control is Non-functional	OFF
Test Mode	Slow Flash
Lockout Active	Fast Flash
Dehumidification Mode	Flash Code 2
(Future Use)	Flash Code 3
(Future Use)	Flash Code 4
Load Shed	Flash Code 5
ESD	Flash Code 6
(Future Use)	Flash Code 7

Configuration LED (LED2, Yellow)

Description of Operation	Configuration LED, Yellow
No Software Overwritten	Flashing ECM Setting
DIP Switch was Overwritten	Slow Flash
ECM Configuration Mode	Fast Flash

Fault LED (LED1, Red)

Red Fault LED		LED Flash Code*	Lockout	Reset/Remove
ABC Basic Faults	Normal - No Faults	OFF	-	
	Fault - Input	1	No	Auto
	Fault - High Pressure	2	Yes	Hard or Soft
	Fault - Low Pressure	3	Yes	Hard or Soft
	Fault - Freeze Detection FP2	4	Yes	Hard or Soft
	Fault - Freeze Detection FP1	5	Yes	Hard or Soft
	Fault - Condensate Overflow	7	Yes	Hard or Soft
	Fault - Over/Under Voltage	8	No	Auto
	Fault - FP1 & FP2 Sensor Error	11	Yes	Hard or Soft

NOTE: All codes >11 use long flash for tens digit and short flash for the ones digit. 20, 30, 40, 50, etc. are skipped.

Aurora Interface and Diagnostics (AID) Tool

The Aurora Interface and Diagnostics (AID) Tool is a device that is a member of the Aurora network. The AID Tool is used to troubleshoot equipment which uses the Aurora control via Modbus RTU communication. The AID Tool provides diagnostics, fault management, ECM setup, and system configuration capabilities to the Aurora family of controls. An AID Tool is recommended, although not required, for ECM airflow settings. The AID Tool simply plugs into the exterior of the cabinet in the AID Tool port.



ABC Control Board Layout

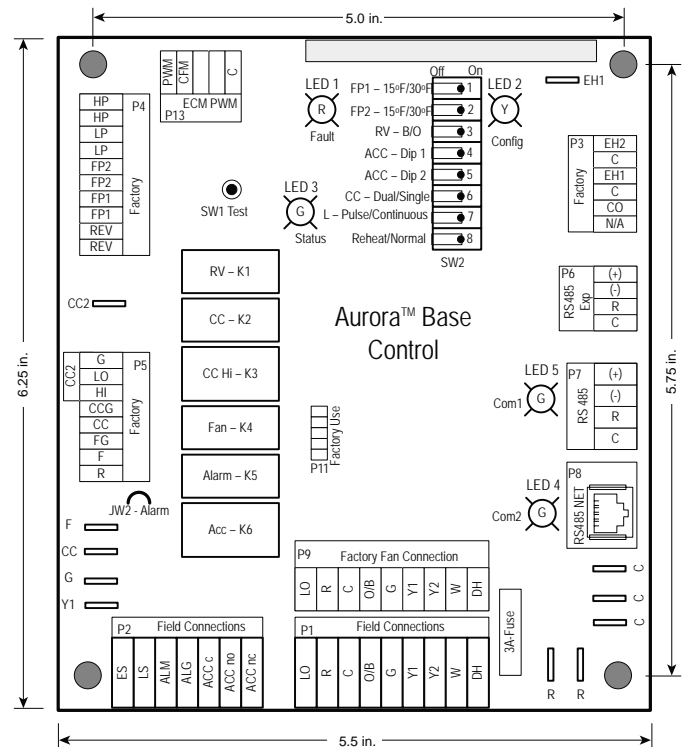

Controls - UPC DDC Control (optional)



Aurora UPC Controller

The Aurora Unitary Protocol Converter (UPC) is designed to add-on to any Aurora based heat pump control. The Aurora Unitary Protocol Converter (UPC) is designed to allow water source heat pumps to be integrated into Building Automation Systems (BAS) with ease. The Aurora UPC is an integrated solution and communicates directly with the Aurora Heat Pump Controls and allows access/control of a variety of internal Aurora heat pump operations such as sensors, relay operation, faults and other information. In turn, the UPC then converts internal Aurora Modbus protocol to BACnet MS/TP, LON, or N2 protocols and communicates to the BAS system. This provides the great benefit of complete control integration and a myriad of information available to the BAS from the heat pump control. Plus it also allows individual unit configuration such as ECM fan speeds or freeze protection setting directly over the BAS without the need for access to the actual heat pump. The Aurora UPC is programmed using the powerful Eikon object oriented.

The Aurora UPC is implemented with the Aurora Base Controller (ABC) heat pump control into our latest water source heat pumps. This will allow for a BAS to integrate



ZS Series Sensors

and communicate to the heat pump thru a choice of 3 different communication protocols. The Aurora UPC has the ability to communicate BACnet MS/TP, N2 open, or LonWorks (requires LON Plugin card). This flexibility is possible due to the onboard dipswitches which allow for the desired protocol and baud rate to be selected in the field. All zone temperatures and zone sensors are connected to the UPC on an RNet bus, simplifying hook up at the unit. RNet sensors can include a combination of zone temperature and humidity, CO₂, and VOC sensors. The UPC includes built-in support for a custom configurable keypad/display unit - BACview6 (4-line by 40 character per line display) or BACview5 (2-line by 16 character per line display). Up to 2 Keypad/display units can be mounted remotely for configuration and troubleshooting.

There are an extensive number of points that the UPC has available over the network for integration into the BAS. Control programmers need to carefully determine which points they want to add into the BAS database. A list of the BACnet points, N2 points, and LON SNVTs are available along with their individual point descriptions by contacting the Commercial Solutions Group at 1-877-677-4420.

Controls - UPC DDC Control (optional) cont.

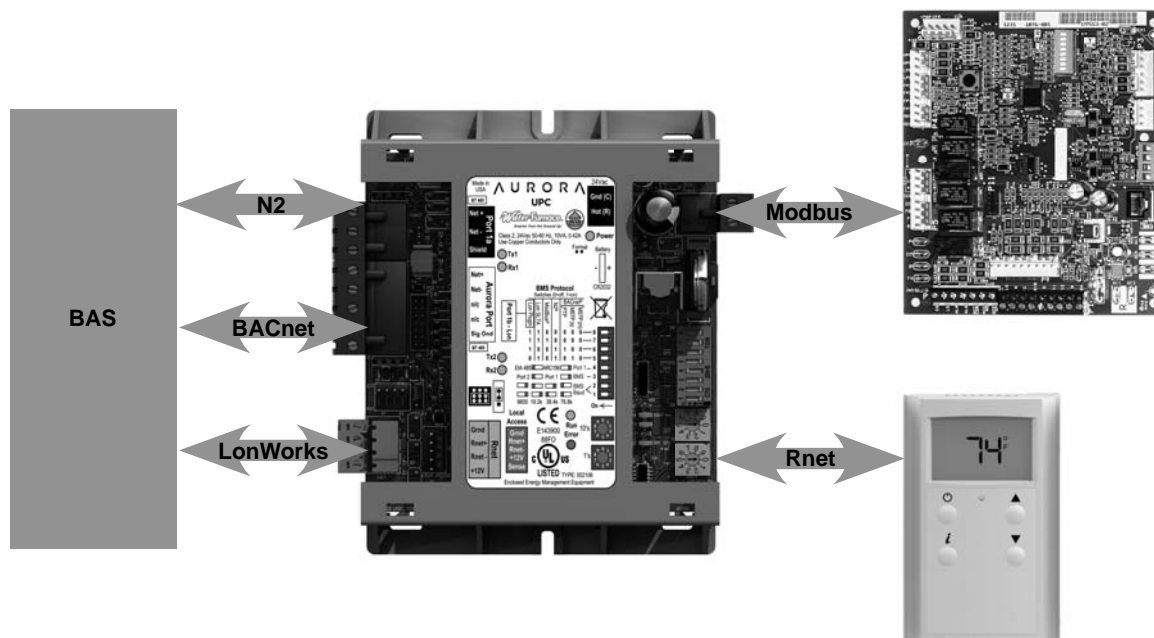

Aurora UPC Features

- Rugged enclosure made of GE C2950 Cycloy plastic
- Built-in surge transient protection circuitry
- Operating range of -20° to 140°F; 10 to 95% relative humidity, non-condensing
- Onboard CR123A battery has a life of 10 years with 720 hours of cumulative power outage
- Multi-Protocol field selectable communication port that supports:
 - EIA-485 BACnet MS/TP @ 9600, 19.2k, 38.4k, 76.8k baud
 - Metasys N2 Open
 - LonWorks TP/FT-10 (Requires optional LON plug-in communication card)
- Status of all unit operating conditions and fault lockouts
- Visual LED's for status of power, network communication, processor operation, and errors
- Provides gateway into Aurora heat pump controls for unsurpassed control flexibility
 - Network point for commanding unit into load shed
 - Network point for commanding unit into emergency shutdown
 - Network points to assist in fan speed selection
 - Network points for freeze protection settings
- Heating and cooling control from a remotely located zone sensor
- Rnet communication port which allows for multiple Rnet zone sensors (5) to be connected for space temperature averaging if desired.
- Local laptop or BACview connection for field service
- FCC, UL and CE listed. BTL Certification is pending

Aurora UPC Optional Features

- BACview handheld display, needed for field configuration of fan speeds, set points, etc.
- AID Tool for Aurora ABC configuration and troubleshooting.
- Aurora Advanced Control adds the Aurora AXB expansion board and provides added I/O and standard features
- Optional Sensor Kits (requires Aurora Advanced Control with AXB - Future Availability on Select Models/Configurations)
 - **Refrigeration Monitoring** - provides Suction and discharge pressure, Suction, liquid line temps and superheat and subcooling.
 - **Performance Monitoring** - provides entering and leaving loop water temperatures, loop flow rate as well as heat of extraction or rejection rate into the loop.
 - **Energy Monitoring** - provides real-time power measurement (Watt) of compressor, fan, auxiliary heat and zone pump.
- Graphics packages available in the future

Controls - UPC DDC Control (optional) cont.

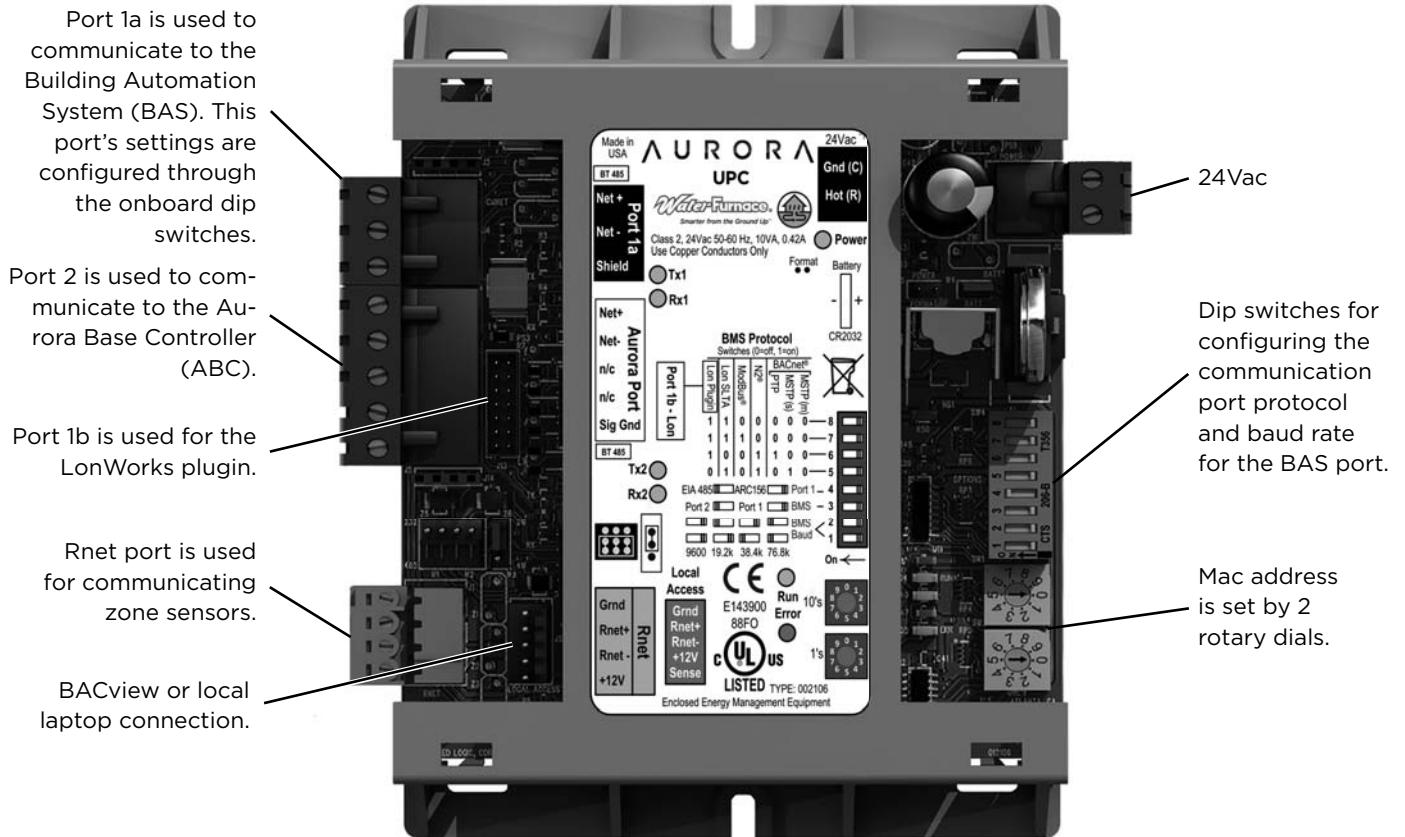

Aurora Touch Interface

Utilizing a touch-screen interface, the UPC provides a technician the ability to configure and diagnose equipment at the unit or from any room sensor for added accessibility and simpler troubleshooting. The technician will have full access to equipment status, parameter values, temperature, and humidity sensing as well as access to alarm and trend history. With website-like navigation, the Aurora Touch Interface is easy to use and provides important insight into the system so your building can operate as efficiently as possible.

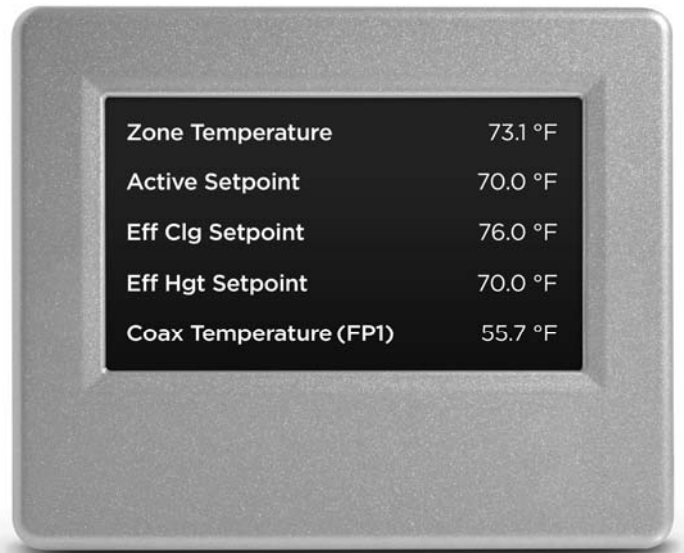

Controls - UPC DDC Control (optional) cont.

- 1. **Leaving Air Temperature (LAT) Sensor** - This 10 kOhm NTC sensor is factory installed on all UPC equipped heat pumps. It typically is attached to wiring inside the blower cabinet on the suction side of the blower. This sensor is attached on ABC FP2 pins available as LAT AU-30.
- 1. **Compressor Proving Sensors** - This optional factory installed current sensor is connected to confirm compressor operation via the power wires. The sensor is attached at ABC Y1 and available at point BV-65.
- 1. **Valve End Switch** - This optional input is setup for a field installed flow valve end switch. This end switch input is attached at ABC Y2 and available at point BV-67.
- 1. **Fan Proving Sensors** - This optional factory installed current sensor is connected to confirm fan operation via the power wires. The sensor is attached at ABC G and available at point BV-33.
- 1. **Occupancy Sensor** - This standard feature includes a field installed and wired room sensor with occupancy sensor typically found in DDC systems. The RNet room sensors can be found thru your commercial representative. The occupancy Sensors are attached at ABC O and can be found at point BV-49.

- 1. **Dirty Filter Switch** - This optional field installed switch is connected to confirm dirty filter operation. The dirty filter switch can be found thru your commercial representative. The sensor is attached at ABC W and available at point BV-63.
- 2. **Fault, Configuration, and Status Codes** - The codes can be visible to the BAS if desired

Aurora Base Fault Codes (ABC Only)

Fault LED (LED1, Red)

	Red Fault LED	LED Flash Code*	Lockout	Reset/Remove
ABC Basic Faults	Normal - No Faults	OFF	-	
	Fault - Input	1	No	Auto
	Fault - High Pressure	2	Yes	Hard or Soft
	Fault - Low Pressure	3	Yes	Hard or Soft
	Fault - Freeze Detection FP2	4	Yes	Hard or Soft
	Fault - Freeze Detection FP1	5	Yes	Hard or Soft
	Fault - Condensate Overflow	7	Yes	Hard or Soft
	Fault - Over/Under Voltage	8	No	Auto
	Fault - FP1 & FP2 Sensor Error	11	Yes	Hard or Soft

NOTE: All codes >11 use long flash for tens digit and short flash for the ones digit. 20, 30, 40, 50, etc. are skipped.

Aurora Advanced Fault Codes (ABC + AXB Expansion Board)

Fault LED (LED1, Red)

	Red Fault LED	LED Flash Code *	Lockout	Reset/Remove	Fault Condition Summary
ABC Basic Faults	Normal - No Faults	Off	-		
	Fault-Input	1	No	Auto	Tstat input error. Autoreset upon condition removal.
	Fault-High Pressure	2	Yes	Hard or Soft	HP switch has tripped (>600 psi)
	Fault-Low Pressure	3	Yes	Hard or Soft	Low Pressure Switch has tripped (<40 psi for 30 continuous sec.)
	Fault-Freeze Detection FP2	4	Yes	Hard or Soft	Freeze protection sensor has tripped (<15 or 30 degF for 30 continuous sec.)
	Fault-Freeze Detection FP1	5	Yes	Hard or Soft	Freeze protection sensor has tripped (<15 or 30 degF for 30 continuous sec.)
	Fault-Condensate Overflow	7	Yes	Hard or Soft	Condensate switch has shown continuity for 30 continuous sec.
	Fault-Over/Under Voltage	8	No	Auto	Instantaneous voltage is out of range. **Controls shut down until resolved.
ABC & AXB Advanced Faults	Fault-FP1 & 2 Snsr Error	11	Yes	Hard or Soft	If FP1 or 2 Sensor Error
	Fault-Compressor Monitor	10	Yes	Hard or Soft	Open Crkt, Run, Start or welded cont
	Non-CriticAXBSnsrErr	13	No	Auto	Any Other Sensor Error
	CriticAXBSnsrErr	14	Yes	Hard or Soft	Sensor Error for EEV or HW
	Alert-HotWtr	15	No	Auto	HW over limit or logic lockout. HW pump deactivated.
	Fault-VarSpdPump	16	No	Auto	Alert is read from PWM feedback.
	Not Used	17	No	Auto	I22 Com Fault. Autoreset upon condition removal.
	Non-CritComErr	18	No	Auto	Any non-critical com error
	Fault-CritComErr	19	No	Auto	Any critical com error. Auto reset upon condition removal
	Alarm - Low Loop Pressure	21	No	Auto	Loop pressure is below 3 psi for more than 3 minutes
	Alarm - Home Automation 1	23	No	Auto	Closed contact input is present on Dig 2 input - Text is configurable
	Alarm - Home Automation 2	24	No	Auto	Closed contact input is present on Dig 3 input - Text is configurable

NOTES:

*All codes >11 use long flash for tens digit and short flash for the ones digit. 20, 30, 40, 50 etc. are skipped!
 Alert' is a noncritical sensor or function that has failed. Normal operation of the heat pump is maintained but service is desired at some point.

Controls - UPC DDC Control (optional) cont.

Aurora Base or Advanced Control Configuration and Status Codes

Status LED (LED3, Green)

Description of Operation	Fault LED, Green
Normal Mode	ON
Control is Non-functional	OFF
Test Mode	Slow Flash
Lockout Active	Fast Flash
Dehumidification Mode	Flash Code 2
Load Shed	Flash Code 5
Emergency Shutdown	Flash Code 6
On Peak Mode	Flash Code 7
(Future Use)	Flash Code 8
(Future Use)	Flash Code 9

Configuration LED (LED2, Yellow)

Description of Operation	Configuration LED, Yellow
No Software Overwritten	ECM Setting
DIP Switch Overwritten	Slow Flash
ECM Configuration Mode	Fast Flash
Reset Configuration Mode	OFF

9. Alarm Relay - The Alarm relay (ALM) is factory connected to 24 VAC via jumper JW2. By cutting JW2, ABC ALM becomes a dry contact connected to ABC ALG. The Relay is field switchable between Factory setting as an Alarm output or available for other uses.

10. Accessory Relay1 - A configurable, accessory relay on the ABC is provided that can be cycled with the compressor, blower, or the Dehumidifier (DH) input. A third (factory) setting cycles the relay with the compressor but delays the compressor and blower output for 90 sec. Source pump or slow opening solenoid valves in well systems or variable speed primary pumping systems would be a prime use of this feature.

Access Relay Operation	SW2-4	SW2-5
Cycle with Blower	ON	ON
Cycle with Compressor	OFF	OFF
Water Valve Slow Opening	ON	OFF
Cycle with Comm. T-stat Hum Cmd	OFF	ON

11. Electric Heat EH1 - A digital 24VDC output is provided for electric heat powering. UPC's Default programming has EH1 set for AUX/ELEC Heat operation and will be controlled using the UPC's internal P.I.D. logic. However it can be changed by the BAS to be network controlled.

12. Electric Heat EH2 - A digital VDC output is provided for field options converted from the original EH2 output. Default UPC program has the EH2 output set for Network Control but can be changed by the BAS to be controlled by the UPC's internal P.I.D. logic.

Controls - UPC DDC Control (optional) cont.

Aurora Advanced Control Configuration and Options (Future Availability on Select Models/Configurations)

1. **Accessory Relay2** - A second, configurable, accessory relay on the AXB is provided that can be cycled with the compressor 1 or 2, blower, or the Dehumidifier (DH) input. This is to complement the Accessory 1 Relay on the ABC board.

Position	DIP 4	DIP 5	Description
1	ON	ON	Cycles with Fan or ECM (or G)
2	OFF	ON	Cycles with CC1 first stage of compressor or compressor spd 1-12
3	ON	OFF	Cycles with CC2 second stage of compressor or compressor spd 7-12
4	OFF	OFF	Cycles with DH input from ABC board

2. **Analog Out** - A standard 0-10VDC analog output is provided. This output can be used to drive modulating dampers etc.
3. **Variable Speed Pump or Modulating Water Valve** - This input and output are provided to drive and monitor a variable speed pump. The VS pump output is a PWM signal to drive the variable speed pump. The minimum and maximum level are set using the AID Tool. 75% and 100% are the default settings respectively. The VS data input allows a separate PWM signal to return from the pump giving fault and performance information. Fault received from the variable speed pump will be displayed as E16. **Modulating Water Valve** - This Variable speed PWM output is provided to optionally drive a modulating water valve. Through advanced design a 0-10VDC valve can be driven directly from the VS pump output. The minimum and maximum level are set in the same way as the VS pump using the AID Tool. 75% and 100% are the default settings respectively.
4. **Loop Pump Slaving** - This input and output are provided so that two units can be slaved together with a common flow center. When either unit has a call for loop pump, both unit's loop pump relays and variable speed pumps are energized. The flow center then can simply be wired to either unit. The output from one unit should be routed to the input of the other. If daisy chained up to 16 heat pumps can be wired and slaved together in this fashion.

Controls - UPC DDC Control (optional) cont.

Aurora Advanced Control Optional Sensor Kits (Future Availability on Select Models/Configurations)

1. **Energy Monitoring (Standard Sensor Kit on 'Advanced' models)** - The Energy Monitoring Kit includes two current transducers (blower and electric heat) added to the existing two compressor sensors so that the complete power usage of the heat pump can be measured. The BACview Tool provides configuration detail for the type of blower motor and a line voltage calibration procedure to improve the accuracy. This real time power usage information can be displayed on the AID Tool and is available thru network points when using BACnet or N2 Open.
 - Compressor Current 1
 - Compressor Current 2
 - Fan Current
 - Aux Heat Current
 - Pump Selection
 - Voltage
 - Compressor Watts
 - Fan Watts
 - Aux Heat Watts
 - Pump Watts (VS Only)
2. **Refrigerant Monitoring (optional sensor kit)** - The optional Refrigerant Monitoring Kit includes two pressure transducers, and three temperature sensors, heating liquid line, suction temperature and existing cooling liquid line (FP1). These sensors allow the measurement of discharge and suction pressures, suction and liquid line temperatures as well as superheat and subcooling. This information can be displayed on the BACview Tool, or the network when using BACnet and N2.
 - Htg Liquid Line
 - Clg Liquid Line
 - Discharge pressure
 - Suction Pressure
 - Discharge Saturated Temp
 - Suction Saturated Temperature
 - Superheat
 - SubCooling
3. **Performance Monitoring (optional sensor kit)** - The optional Performance Monitoring Kit includes: three temperature sensors, entering and leaving water, leaving air temperature and a water flow rate sensor. With this kit, heat of extraction and rejection will be calculated. This requires configuration using the BACview Tool for selection of water or antifreeze.
 - Leaving Air Temperature (supply)
 - Alt Leaving Air Temperature (Supply)
 - Entering Water Temperature
 - Leaving Water Temperature
 - Water Flow Meter
 - Entering Air Temperature (from zone sensor)
 - Brine Selection (water/antifreeze)
 - Heat of Extraction/Rejection

Controls - UPC DDC Control (optional) cont.

ZS Series RNet Sensor Overview

The ZS Series line of intelligent zone sensors provides the function and flexibility you need to manage the conditions important to the comfort and productivity of the zone occupants. The ZS sensors are available in a variety of zone sensing combinations to address your application needs. These combinations include temperature, relative humidity, and indoor air quality (carbon dioxide or VOCs (Volatile Organic Compounds)). They are built to be flexible allowing for easy customization of what the user/technician sees. Designed to work with the Aurora UPC controllers the ZS sensor line includes the ZS Base, ZS Plus, ZS Pro and ZS Pro-F.

The UPC uses a proprietary communication called Rnet to receive the space temperature from the zone sensor.

This is done using (2) 18 AWG twisted pair unshielded cables for a total of 4 wires connected to the Rnet port. The sensor gets its power from the UPC controller and connecting multiple sensors to one UPC will allow for space temperature averaging. The UPC can support one ZS Pro or ZS Pro F with up to four ZS standard sensors wired to the Rnet port on the UPC for a total of 5 zone sensors. The sensors use a precise 10k ohm thermistor with less than 0.18°F drift over a ten year span, this allows for less maintenance or re-calibration after installation. The sensors also have a hidden communication port for connecting a BACview or local laptop that provides access to the equipment for commissioning and maintenance. The table below shows the features of each of the four sensors that are currently available.

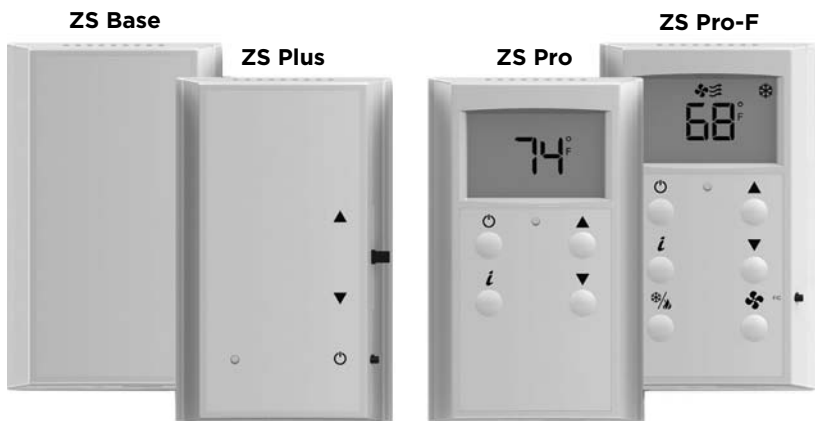

Features	ZS Base	ZS Plus	ZS Pro	ZS Pro-F
Temp, CO ² , Humidity, and VOC Options	✓	✓	✓	✓
Neutral Color	✓	✓	✓	✓
Addressable/supports daisy chaining	✓	✓	✓	✓
Hidden communication port	✓	✓	✓	✓
Mounts on a standard 2" by 4" electrical box	✓	✓	✓	✓
Occupancy Status indicator LED		✓	✓	✓
Push button occupancy override		✓	✓	✓
Setpoint adjust		✓	✓	✓
Large, easy to read LCD			✓	✓
Alarm indicator			✓	✓
°F to °C conversion button				✓

Options	Part Number	Part Number	Part Number	Part Number
Temperature Only	ZSU	ZSUPL	ZSUP	ZSUPF
Temp with CO ²	ZSU-C	ZSUPL-C	ZSUP-C	ZSUPF-C
Temp with Humidity	ZSU-H	ZSUPL-H	ZSUP-H	ZSUPF-H
Temp with Humidity, CO ²	ZSU-HC	ZSUPL-HC	ZSUP-HC	ZSUPF-HC
Temp, Humidity, VOC	ZSU-HV	ZSUPL-HV	ZSUP-HV	ZSUPF-HV
Temp with VOC	ZSU-V	ZSUPL-V	ZSUP-V	ZSUPF-V

Controls - UPC DDC Control (optional) cont.

RNet Sensor Physical and Electrical Data

Sensing Element	Range	Accuracy
Temperature (on non-Humidity models)	-4° to 122° F (-20° C to 50° C)	30.35° F (0.2° C)
Temperature (on Humidity models)	50° F to 104° F (10° C to 40° C)	30.5° F (0.3° C)
Humidity	10% to 90%	31.8% typical
CO2	400 to 1250 PPM 1250 to 2000 PPM	330PPM or +/-3% of reading (greater of two) 35% of reading plus 30 PPM
VOC	0 to 2,000 PPM	3100 PPM
Power Requirements	Sensor Type	Power Required
Temperature Only	All Models	12 Vdc @ 8 mA
Temperature with Humidity	All Models	12 Vdc @ 15 mA (idle) to 190 mA (CO2 measurement cycle)
Temp with VOC, or Temp/VOC/Humidity	All Models	12 Vdc @ 60 mA
Temp with CO2 , or Temp/ CO2/Humidity	All Models	12 Vdc @ 15 mA (idle) to 190 mA (CO2 measurement cycle)
Power Supply	A controller supplies the Rnet sensor network with 12 Vdc @ 210 mA. Additional power may be required for your application. See sensor ZS Installation Guide	
Communication	115 kbps Rnet connection between sensor(s) and controller 15 sensors max per Rnet network; 5 sensors max per control program	
Local Access Port	For connecting a laptop computer to the local equipment for maintenance and commissioning	
Environmental Operating Range	32° to 122° F (0° - 50° C), 10% to 90% relative humidity, non-condensing	
Mounting Dimensions	Standard 4"x 2" electrical box using provided 6/32" x 1/2" mounting screws	

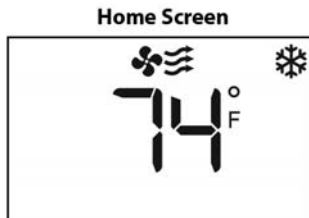
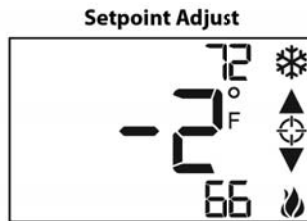
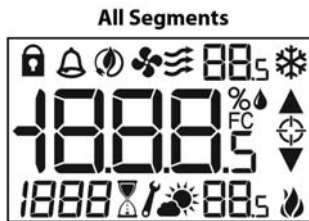

Temperature Only or Temperature with Humidity

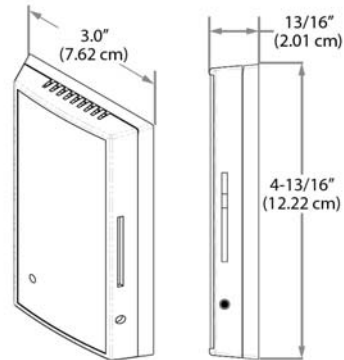

Sensor with CO₂ or VOC

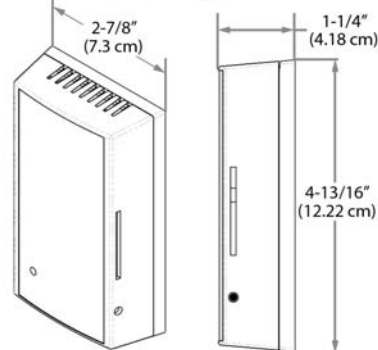

Hot Gas Reheat/Hot Gas Bypass

Hot Gas Reheat Description

The refrigerant flows in normal heat pump path in heating and cooling mode. During the Reheat mode, the operation begins with superheated vapor leaving the compressor going through the reheat valve to the reheat air coil. In the reheat coil the high temperature high pressure gas reheats the air exiting the unit to near neutral. Next, the refrigerant exits the reheat coil and passes through a check valve, which is used to prevent refrigerant flow into the reheat coil during normal heating and cooling operation. The refrigerant passes through the check valve and is then diverted to the coaxial heat exchanger by the four way reversing valve. The hot gas enters the coaxial heat exchanger which will condense the gas to a high pressure liquid due to heat being rejected to the loop fluid. The high pressure liquid leaves the coax and enters the inlet of the TXV. After passing through the TXV the low pressure mixture of liquid/vapor refrigerant expands in the air coil evaporating into a low pressure low temperature

gas and moves back through the reversing valve and into the compressor suction. The cycle then starts again by compressing the low pressure low temperature gas into a superheated vapor. A small copper bleed line is located on the reheat/reclaim valve to allow refrigerant that has migrated to the reheat coil to escape.

Hot Gas Bypass Description

The hot gas bypass (HGB) option is designed to limit the minimum evaporating pressure in the cooling mode to prevent the air coil from icing. The HGB valve senses pressure at the outlet of the evaporator by an external equalizer. If the evaporator pressure decreases to 115 psig the HGB valve will begin to open and bypass hot discharge gas into the inlet of the evaporator. The valve will continue to open as needed until it reaches its maximum capacity. Upon a rise of suction pressure, the valve will begin to close back off and normal cooling operation will resume.

Hot Gas Reheat/Hot Gas Bypass cont.

Hot Gas Reheat Dehumidification Overview Dehumidification - The Need for Reheat

With tighter construction and more and more ventilation air being introduced into buildings, there is more need now than ever for proper humidity control. Ensuring dehumidification can provide consistent employee comfort, a reduction in mold liability, a reduction in cooling costs. Reduced humidity also provides an improvement in indoor air quality (IAQ) thru lower humidity levels which can reduce allergen levels, inhibit mold and bacterial growth, and provide an improved computer environment. ASHRAE 90.1 speaks of an acceptable humidity range in all commercial buildings.

Typical Reheat Applications

Reheat can be used wherever moisture is a problem. Schools, high latent auditorium and theaters, makeup air units*, and computer rooms are typical applications. Although reheat equipped water source heat pumps (wshp's) can condition limited amounts of outdoor air, the percentage of this outdoor air should never exceed 50% of the return air to the unit limiting the mixed return air temperature to a minimum of 50°F. When cold entering air conditions are anticipated, hot gas bypass option should be considered to prevent air coil freeze up.

*A dedicated outdoor air system (DOAS) should be investigated for 100% outdoor air applications.

The Design of Reheat Equipment

Hot gas reheat can help maintain specific humidity levels and neutral air in a building. ASHRAE recommends a relative humidity range of 30-60% with levels greater than 65% making mold growth a possibility. The dehumidification relative humidity set points of 57% (on) and 52% (off) are recommended. During reheat the leaving air temperature (LAT) will approximate neutral air. The included chart (Leaving Air Temperature vs. Entering Water and Air Conditions Chart) shows the LAT vs entering water temperature (EWT) to the unit at differing entering air conditions. At 86-90°F EWT the unit will provide nearly neutral air.

Moisture Removal Capacity

The amount of moisture removal may be calculated by subtracting the sensible cooling capacity from the total cooling capacity in the equipment performance data of the specifications catalog or submittal data. An example is shown below:

Model NB*048, 1275 cfm, 12 gpm, 90°F EWT

$$TC - SC = LC$$

$$46.5 - 34.6 \text{ MBtu/h} = 11.9 \text{ MBtu/h}$$

Where TC = total cooling capacity, SC=sensible capacity, LC=latent capacity

Leaving Air Temperature vs. Entering Water and Air Conditions Chart

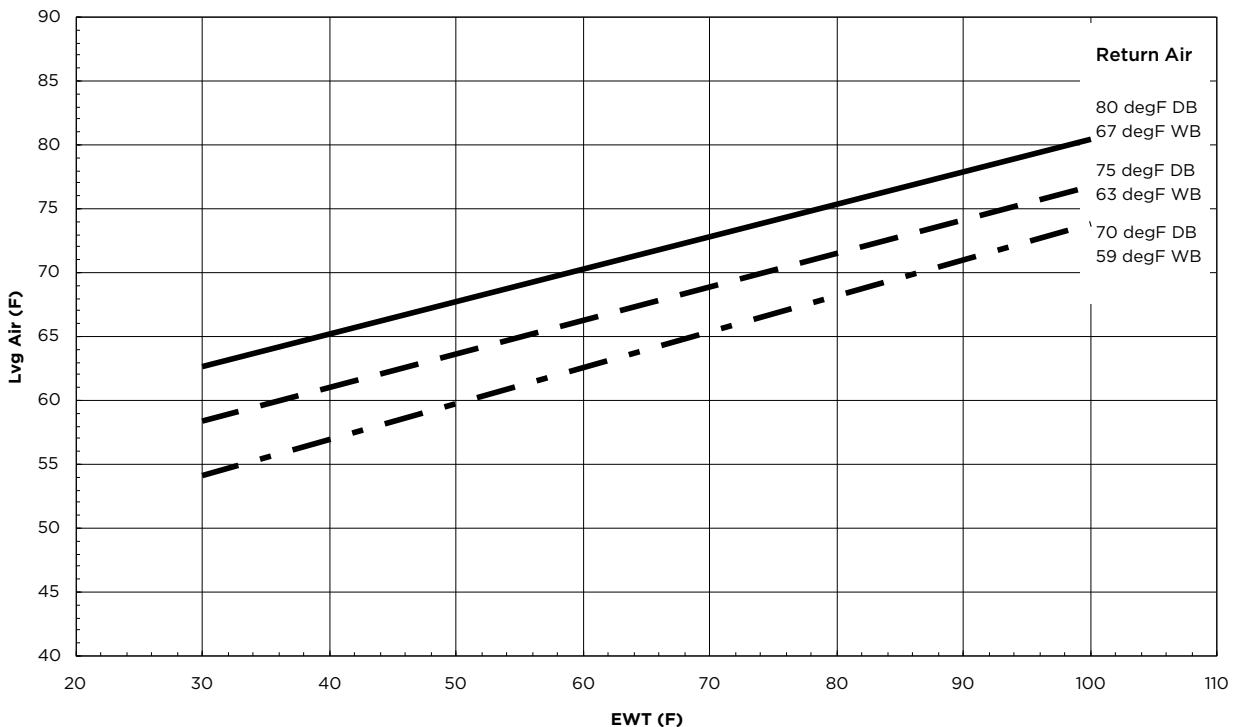

Hot Gas Reheat/Hot Gas Bypass cont.

Hot Gas Reheat Dehumidification Overview cont.

Btu/hr may be converted to lbs/hr or grains per hour as shown in the equations below.

$$11,900 \text{ Btu/h} / 1,069 \text{ Btu/lb of water vapor at } 80/67 \text{ DB/WB}^\circ\text{F} = 11.13 \text{ lbs/hr}$$

$$11.13 \text{ lbs/hr} \times 7,000 \text{ grains/lb} = 77,910 \text{ grains/hr}$$

External Static Pressure Adjustment

With a reheat coil option installed an adjustment for external static pressure (ESP) needs to be made. The following table will show the reduction in ESP for any model relating coil air velocity and ESP.

ESP vs. Coil Velocity Table

Coil Velocity (fpm)	250	300	350	400
ESP Increase (in. wg.)	0.10	0.14	0.17	0.20

Variable speed ECM models will generally compensate up to their maximum ESP of 0.5 in. wg. for 1/2 hp and 0.75 in. wg. for 1 hp.

Model NBH048, 1500 cfm,

$$H \times W = SA$$

$$20 \times 40 = 800 \text{ in.}^2 = 5.56 \text{ ft.}^2$$

Where H=fin height of air coil, W=fin length of air coil, SA=fin surface area

Adjustment must be made for dehumidification mode, 85% of cfm,

$$1500 \times 0.85 = 1,275 \text{ cfm}$$

Calculate air velocity, fpm, cfm / SA

$$1,275 \text{ cfm} / 5.56 \text{ ft.}^2 = 229 \text{ fpm}$$

Refer to the ESP vs. Coil Velocity Table and look up the fpm to find ESP increase. If air velocity is below 250 cfm assume 0.10 increase in ESP. Interpolation of data within the table is permitted.

Hot Gas Bypass with Hot Gas Reheat Layout

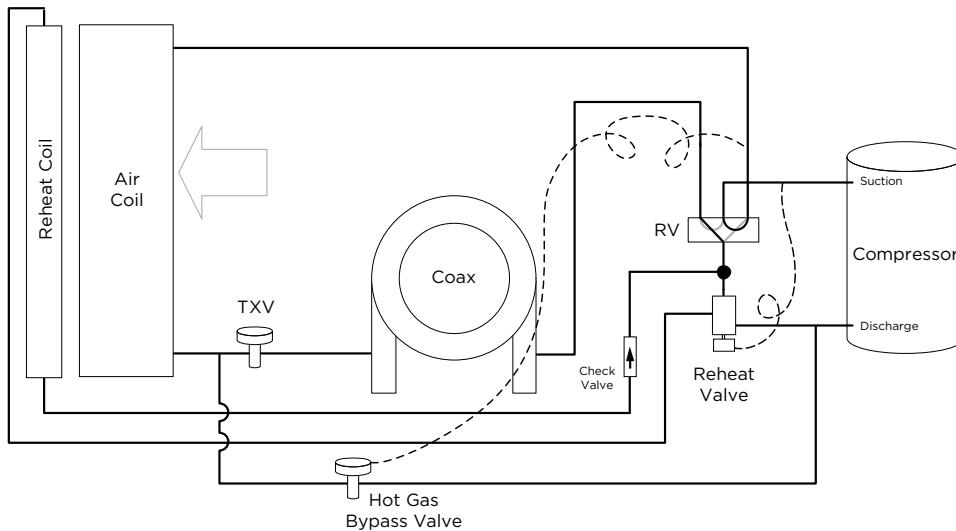

Hot Gas Reheat - Controls

Hot Gas Reheat Controls

The reheat option is available with the Aurora control. The following schemes are available:

Room wall dehumidistat

An optional room wall dehumidistat that controls the reheat mode thru a 24VAC 'Hum' input (On or Off). Setpoint and deadband is determined by the dehumidistat.

Duct humidity sensor (UPC only)

An optional duct humidity sensor is installed. The UPC control reads the humidity from the sensor and determines operation mode. Setpoint and deadband are internally set by the UPC control and are adjustable. Continuous blower operation is a requirement for this mode to accurately measure relative humidity during the off cycle.

Room wall humidity sensor (UPC only)

An optional wall humidity sensor is installed. The UPC control reads the humidity from the sensor and determines operation mode. Setpoint and deadband are internally set by the UPC control and are adjustable. Continuous blower operation is NOT a requirement for this mode.

The unit will cycle thru a 'flush cycle' to purge refrigerant and oil from the idle heat exchanger once every 24 hours when in cooling mode. The UPC control will provide an option to set back reheat to an adjustable unoccupied humidity set point during unoccupied time periods. This option is factory set to "OFF" so reheat will control to one set point at all times. If set back is required during unoccupied times the option must be set to "ON" in the field by the building automation system or a user interface. The dehumidification set back will only work when using a duct humidity sensor or room wall humidity sensor.

Mode of Operation

Please refer to the refrigeration circuit diagram (Hot Gas Reheat - Refrigerant section) and the hot gas reheat wiring schematic.

Heating Mode Operation

Upon a call for heating (Y), blower relay is energized immediately, and the compressor contactor will be energized after a 90 second delay.

Cooling Mode Operation

Upon a call for cooling (Y, O), blower relay and reversing valve coil are energized immediately, and the compressor contactor is energized after a 90 second delay. If there is a call from the de-humidistat or the internal control logic see the humidity sensor has reached set point the blower cfm will be reduced by 15% to increase the unit's latent capacity.

Dehumidification Mode Operation

Upon a call for dehumidification, the blower relay and reversing valve coil are energized immediately, and the compressor contactor will energize after a 90 second delay. The reheat valve coil will energize once the compressor has been operational for 30 seconds.

If a call for space heating is received during reheat operation the compressor will shut down for 5 minutes and the unit will restart in the heating mode. Once the requirement for space heating has been satisfied the unit will shut down for 5 minutes and re-start in reheat mode.

If a call for space cooling is received during reheat operation the reheat valve coil will be disabled until the space cooling requirements have been satisfied. Once the space cooling requirements have been satisfied the reheat valve coil will be energized with out shutting down the compressor.

Dehumidification Set Point (used only with a humidity sensor)

The factory default set point for dehumidification is 52% this is field adjustable from 30% to 60%. In addition there is a factory default differential of 5% field adjustable from 5% to 15%. The control will enable re-heat when the space humidity rises above the set point plus the differential. Depending upon the environmental conditions within the building and the operating parameters of the water source heat pump, the unit may not be capable of maintaining the lower control limit of 30% relative humidity over extended periods of time.

Reheat operation during periods of unoccupancy

This unoccupied set point is useful to reduce energy use in dehumidification. Many system designs greatly reduce or even eliminate fresh air makeup during the unoccupied hours and the need for reheat is lessened. The control logic contains an unoccupied set point that can be used for the unoccupied mode if desired. The factory default for the set point is 60% and is adjustable from 30% to 60%. The unoccupied setback must be enabled either through a building automation system or with a user interface. Factory default for unoccupied setback is off.

Space Humidity High and Low Alarm Limit (building automation system only)

The control has a high and low alarm limit that can be enumerated over a building automation system. The factory default set point for these alarm limits is 0% for the low alarm and 100% for the high alarm limit. These limits can be adjusted though a building automation system. Caution should be used in selecting these limits so as not to cause nuisance alarms.

Application Notes

The Closed Loop Heat Pump Concept

The basic principle of a water source heat pump is the transfer of heat into water from the space during cooling, or the transfer of heat from water into the space during heating. Extremely high levels of energy efficiency are achieved as electricity is used only to move heat, not to produce it. Using a typical WaterFurnace Envision² Series, one unit of electricity will move four to five units of heat.

When multiple water source heat pumps are combined on a common circulating loop, the ultimate in energy efficiency is created: The WaterFurnace units on cooling mode are adding heat to the loop which the units in heating mode can absorb, thus removing heat from the area where cooling is needed, recovering and redistributing that heat for possible utilization elsewhere in the system. In modern commercial structures, this characteristic of heat recovery from core area heat generated by lighting, office equipment, computers, solar radiation, people or other sources, is an important factor in the high efficiency and low operating costs of WaterFurnace closed source heat pump systems.

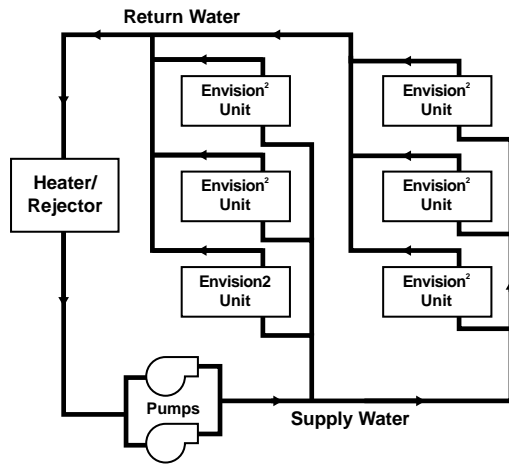

In the event that a building's net heating and cooling requirements create loop temperature extremes, Envision² Series units have the extended range capacity and versatility to maintain a comfortable environment for all building areas. Excess heat can be stored for later utilization or be added or removed in one of three ways; by ground-source heat exchanger loops: plate heat exchangers connected to other water sources, or conventional cooler/boiler configurations. Your WaterFurnace representative has the expertise and computer software to assist in determining optimum system type for specific applications.

The Closed Loop Advantage

A properly applied water source heat pump system offers many advantages over other systems. First costs are

low because units can be added to the loop on an "as needed basis"- perfect for speculative buildings. Installed costs are low since units are self-contained and can be located adjacent to the occupied space, requiring minimal ductwork. Maintenance can be done on individual units without system shut-down. Conditions remain comfortable since each unit operates separately, allowing cooling in one area and heating in another. Tenant spaces can be finished and added as needed. Power billing to tenants is also convenient since each unit can be individually metered: each pays for what each uses. Nighttime and/or weekend uses of certain areas are possible without heating or cooling the entire facility. A decentralized system also means if one unit should fault, the rest of the system will continue to operate normally, as well as eliminating air cross-contamination problems and expensive high pressure duct systems requiring an inefficient electric resistance reheat mode.

The Envision² Series Approach

There are a number of proven choices in the type of Envision² Series system which would be best for any given application. Most often considered are:

Vertical - Closed Loop/Ground Source

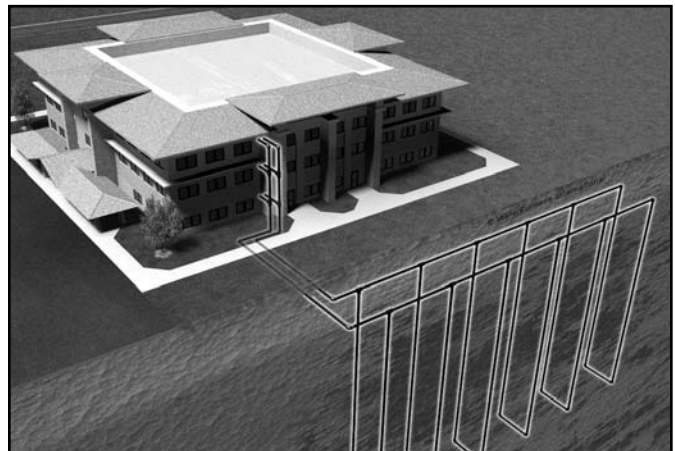

• **Closed Loop/Ground-Source Systems** utilize the stable temperatures of the earth to maintain proper water source temperatures (via vertical or horizontal closed loop heat exchangers) for Envision² Series extended range heat pump system. Sizes range from a single unit through many hundreds of units. When net cooling requirements cause closed loop water temperatures to rise, heat is dissipated into the cooler earth through buried high strength plastic pipe "heat exchangers." Conversely if net space heating demands cause loop heat absorption beyond that heat recovered from building core areas, the loop temperature will fall causing heat to be extracted from the earth. Due to the extended loop temperatures, AHRI/ISO 13256-1 Ground Loop Heat Pumps are required for this application. Because auxiliary equipment such as a fossil fuel boiler and cooling

Application Notes cont.

tower are not required to maintain the loop temperature, operating and maintenance costs are very low.

Ground-source systems are most applicable in residential and light commercial buildings where both heating and cooling are desired, and on larger envelope dominated structures where core heat recovery will not meet overall heating loads. Both vertical and horizontally installed closed-loops can be used. The land space required for the “heat exchangers” is 100-250 sq. ft./ton on vertical (drilled) installations and 750-1500 sq. ft./ton for horizontal (trenched) installations. Closed loop heat exchangers can be located under parking areas or even under the building itself.

On large multi-unit systems, sizing the closed loop heat exchanger to meet only the net heating loads and assisting cooling loads with a closed circuit cooling tower may be the most cost effective choice.

Surface Water - Closed Loop/Ground Source

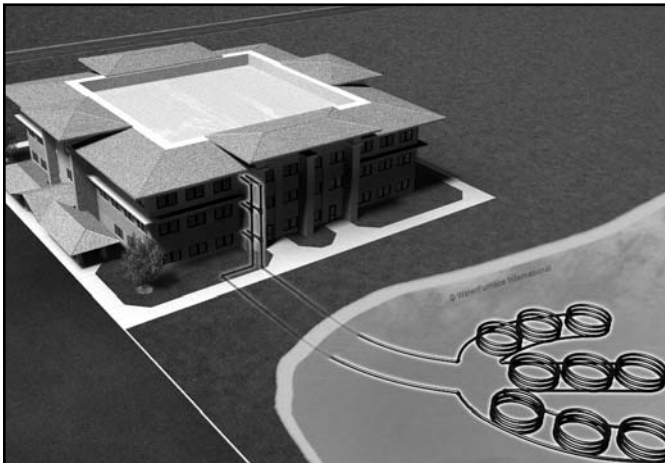

• **Closed Loop/Ground-Source Surface Water Systems** also utilize the stable temperatures of Surface Water to maintain proper water source temperatures for Envision² Series extended range heat pump systems. These systems have all of the advantages of horizontal and vertical closed loop systems. Due to the extended loop temperatures, AHRI/ISO 13256-1 Ground Water or Ground Loop Heat Pumps are required for this application.

In cooling dominated structures, the ground-source surface water systems can be very cost effective especially where local building codes require water retention ponds for short term storage of surface run-off. Sizing requirements for the surface water is a minimum of 500 sq. ft./ton of surface area at a minimum depth of 8 feet. WaterFurnace should be contacted when designs for heating dominated structures are required.

Plate Heat Exchanger - Closed Loop/Ground Water



• **Closed Loop/Ground Water Plate Heat Exchanger Systems** utilize lake, ocean, well water or other water sources to maintain closed loop water temperatures in multi-unit Envision² Compact systems. A plate frame heat exchanger isolates the units from any contaminating effects of the water source, and allows periodic cleaning of the heat exchanger during off peak hours.

Operation and benefits are similar to those for ground-source systems. Due to the extended loop temperatures, AHRI/ISO 13256-1 Ground Loop Heat Pumps are required for this application. Closed loop plate heat exchanger systems are applicable in commercial, marine, or industrial structures where the many benefits of a water source heat pump system are desired, regardless of whether the load is heating or cooling dominated.

Application Notes cont.

Cooler/Boiler - Closed Loop



• **Closed Loop /Cooler-Boiler Systems** utilize a closed heat recovering loop with multiple water source heat pumps in the more conventional manner. Typically a boiler is employed to maintain closed loop temperatures above 60°F and a cooling tower to maintain loop temperatures below 90°F. These systems are applicable in medium to large buildings regardless of whether the load is heating or cooling dominated. Due to the moderate loop temperatures, AHRI/ISO 13256-1 Water Loop Heat Pumps are required for this application.

Water Quality

In ground water situations where scaling could be heavy or where biological growth such as iron bacteria will be present, a closed loop system is recommended. The heat exchanger coils in ground water systems may, over a period of time, lose heat exchange capabilities due to a buildup of mineral deposits inside. These can be cleaned, but only by a qualified service mechanic, as special solutions and pumping equipment are required. Hot water generator coils can likewise become scaled and possibly plugged. In areas

with extremely hard water, the owner should be informed that the heat exchanger may require occasional flushing. Failure to adhere to the guidelines in the water quality table could result in loss of warranty.

Units with cupronickel heat exchangers are recommended for open loop applications due to the increased resistance to build-up and corrosion, along with reduced wear caused by acid cleaning.

Material		Copper	90/10 Cupronickel	316 Stainless Steel
pH	Acidity/Alkalinity	7 - 9	7 - 9	7 - 9
Scaling	Calcium and Magnesium Carbonate	(Total Hardness) less than 350 ppm	(Total Hardness) less than 350 ppm	(Total Hardness) less than 350 ppm
Corrosion	Hydrogen Sulfide	Less than 0.5 ppm (rotten egg smell appears at 0.5 ppm)	10 - 50 ppm	Less than 1 ppm
	Sulfates	Less than 125 ppm	Less than 125 ppm	Less than 200 ppm
	Chlorine	Less than 0.5 ppm	Less than 0.5 ppm	Less than 0.5 ppm
	Chlorides	Less than 20 ppm	Less than 125 ppm	Less than 300 ppm
	Carbon Dioxide	Less than 50 ppm	10 - 50 ppm	10 - 50 ppm
	Ammonia	Less than 2 ppm	Less than 2 ppm	Less than 20 ppm
	Ammonia Chloride	Less than 0.5 ppm	Less than 0.5 ppm	Less than 0.5 ppm
	Ammonia Nitrate	Less than 0.5 ppm	Less than 0.5 ppm	Less than 0.5 ppm
	Ammonia Hydroxide	Less than 0.5 ppm	Less than 0.5 ppm	Less than 0.5 ppm
	Ammonia Sulfate	Less than 0.5 ppm	Less than 0.5 ppm	Less than 0.5 ppm
	Total Dissolved Solids (TDS)	Less than 1000 ppm	1000 - 1500 ppm	1000 - 1500 ppm
	LSI Index	+0.5 to -0.5	+0.5 to -0.5	+0.5 to -0.5
Iron Fouling (Biological Growth)	Iron, FE ²⁺ (Ferrous) Bacterial Iron Potential	< 0.2 ppm	< 0.2 ppm	< 0.2 ppm
	Iron Oxide	Less than 1 ppm, above this level deposition will occur	Less than 1 ppm, above this level deposition will occur	Less than 1 ppm, above this level deposition will occur
Erosion	Suspended Solids	Less than 10 ppm and filtered for max. of 600 micron size	Less than 10 ppm and filtered for max. of 600 micron size	Less than 10 ppm and filtered for max. of 600 micron size
	Threshold Velocity (Fresh Water)	< 6 ft/sec	< 6 ft/sec	< 6 ft/sec

NOTES: Grains = ppm divided by 17
mg/L is equivalent to ppm

2/22/12

Installation Notes

Typical Unit Installation

Unit Location

Locate the unit in an indoor area that allows for easy removal of the filter and access panels. Location should have enough space for service personnel to perform maintenance or repair. Provide sufficient room to make water, electrical and duct connection(s). If the unit is located in a confined space, such as a closet, provisions must be made for return air to freely enter the space by means of a louvered door, etc. Any access panel screws that would be difficult to remove after the unit is installed should be removed prior to setting the unit. On horizontal units, allow adequate room below the unit for a condensate drain trap and do not locate the unit above supply piping. Care should be taken when units are located in unconditioned spaces to prevent damage from frozen water lines and excessive heat that could damage electrical components.

Water Piping

Piping is usually design as 'reverse return' to equalize flow paths through each unit. A short flexible pressure rated hose is used to make connection to the fixed building

piping system. This hose is typically stainless steel braid and includes a swivel fitting on one end for easy removal and is flexible to help isolate the unit for quieter operation. Isolation valves for servicing, y-strainers for filtering and memory-stop flow valve or a balancing valve can be provided for consistent water flow through the unit.

All unit source water connections are fittings that accept a male pipe thread (MPT). Insert the connectors by hand, then tighten the fitting with a wrench to provide a leakproof joint. The open and closed loop piping system should include pressure/temperature ports for serviceability. The proper water flow must be provided to each unit whenever the unit operates. To assure proper flow, use pressure/temperature ports to determine the flow rate. These ports should be located at the supply and return water connections on the unit. The proper flow rate cannot be accurately set without measuring the water pressure drop through the refrigerant-to-water heat exchanger. Never use flexible hoses smaller than the inside diameter of the water connection at the unit. Limit hose length to 10 feet per connection. Check carefully for water leaks.

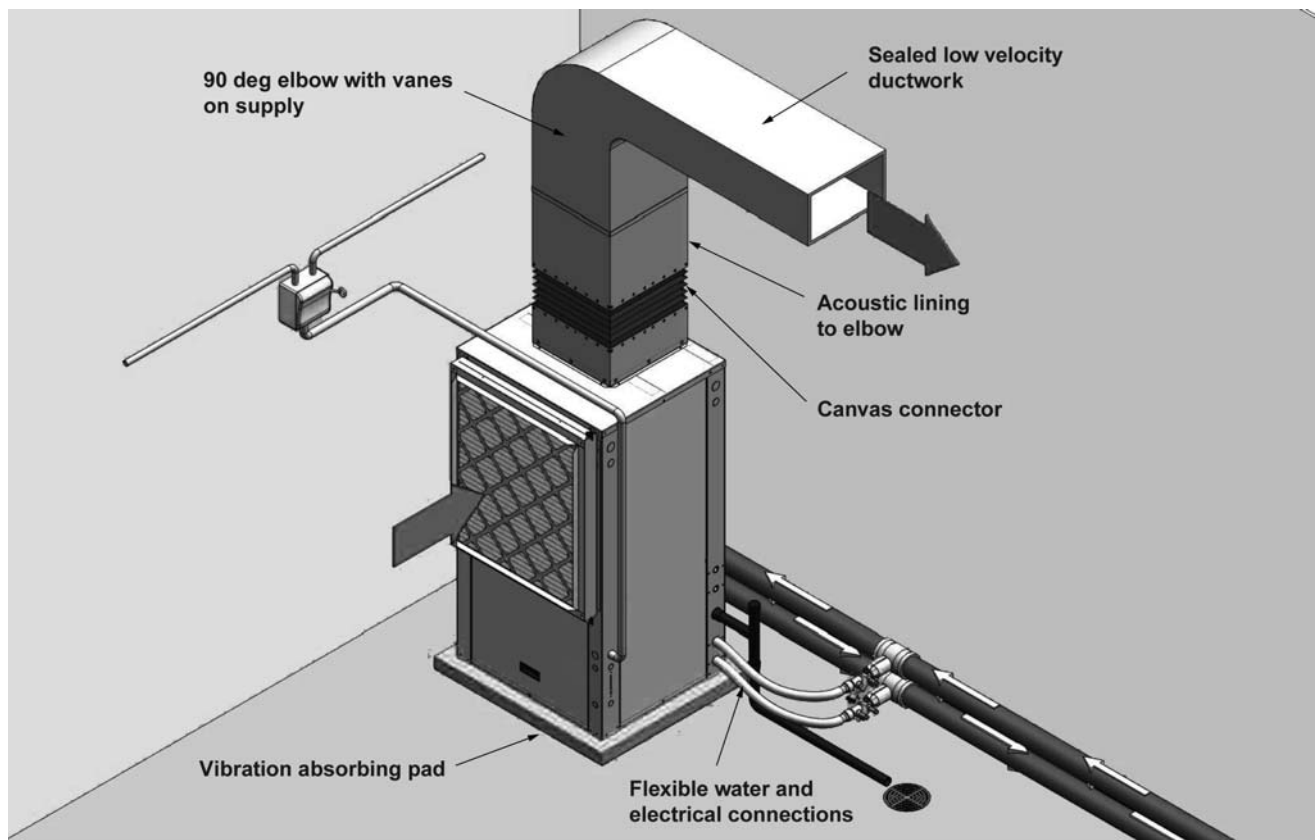

Installation Notes cont.

Installing Horizontal Units

Remove and discard the compressor hold down shipping bolt located at the front of the compressor mounting bracket prior to setting the unit in place. Horizontal units are available with side or end discharge.

NOTE: Horizontal units are normally suspended from a ceiling by four (009-060 models) or five (070-072 models) 3/8 in. diameter threaded rods. The rods are usually attached to the unit by hanger bracket kits furnished with each unit.

Lay out the threaded rods per the Hanger Bracket Dimensions table. Assemble the hangers to the unit as shown. Securely tighten the brackets to the unit using the weld nuts located on the underside of the bottom panel. When attaching the hanger rods to the bracket, a double nut is required since vibration could loosen a single nut. To allow filter access, install hanger brackets as illustrated

in the Hanger Bracket Locations section. The unit should be pitched approximately 1/4 in. towards the drain in both directions to facilitate the removal of condensate. Use only the bolts provided in the kit to attach hanger brackets. The use of longer bolts could damage internal parts.

Some applications require the installation of horizontal units on an attic floor. In this case, the unit should be set in a full size secondary drain pan on top of a vibration absorbing pad. The secondary drain pan prevents possible condensate overflow or water leakage damage to the ceiling. The secondary drain pan is usually placed on a plywood base isolated from the ceiling joists by additional layers of vibration absorbing material.



CAUTION: Do not use rods smaller than 3/8 in. diameter since they may not be strong enough to support the unit. The rods must be securely anchored to the ceiling.

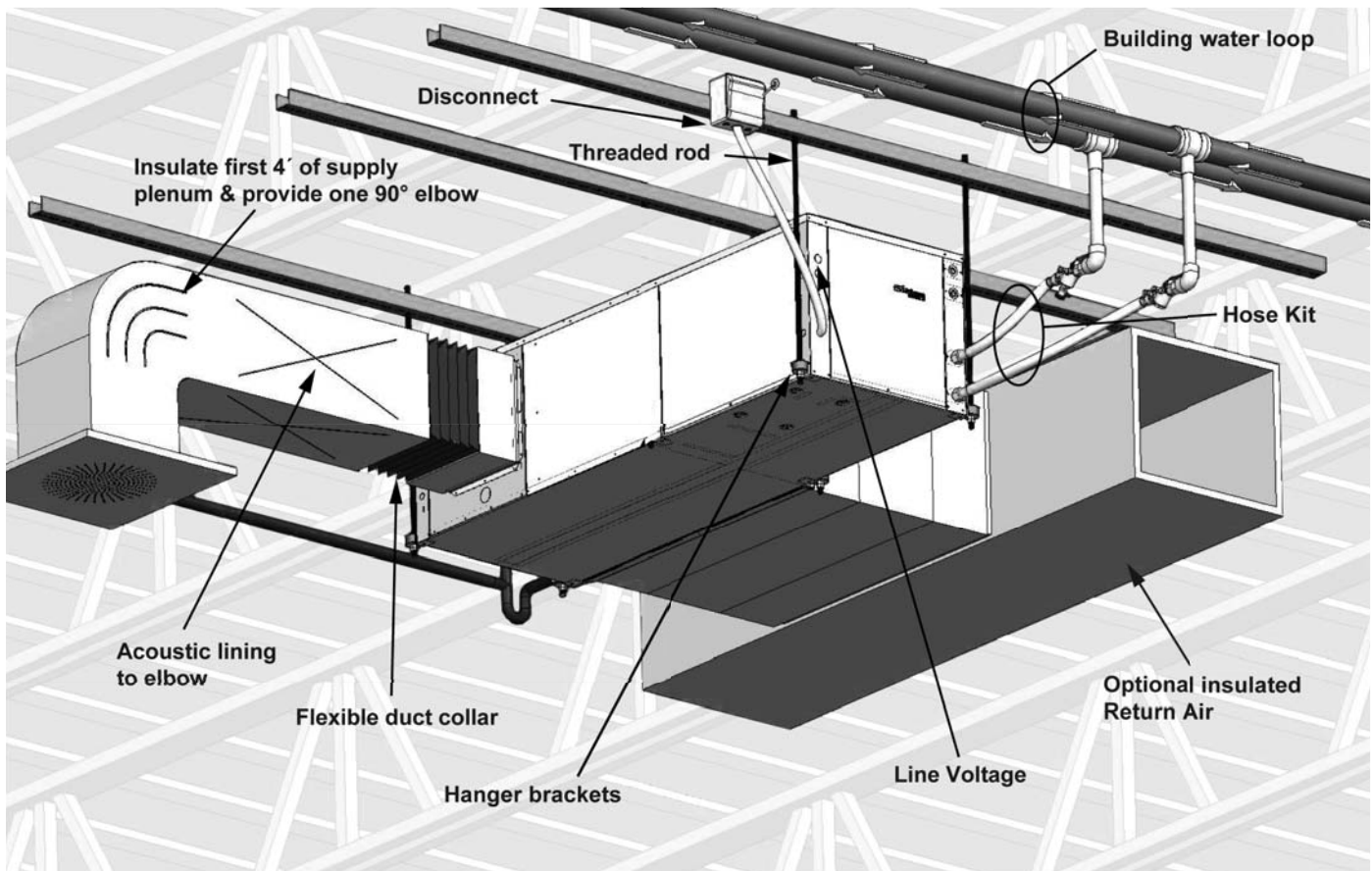

Installation Notes cont.

Acoustical Considerations and Equipment Sound Performance

Sound Performance

The Envision² Compact is third party sound rated in accordance with ARI 260. Please consult WaterFurnace Sound Performance Data Catalog for details on the AHRI standard and sound performance data.

Recommendations for Noise Reduction

Horizontal Unit Location

- Specify equipment with quietest sound power ratings
- Do not locate units above areas with a required NC 40 or less
- Space WSHP at least 10 ft (3m) apart to avoid noise summing of multiple units in a space.
- Maximize the height of the unit above the ceiling (horizontal).
- Suspend unit with isolation grommets that are appropriately rated to reduce vibrations (horizontal).

Vertical Unit Location

- Specify equipment with quietest sound power ratings
- Space WSHP at least 10 ft (3m) apart to avoid noise summing of multiple units in a space.
- Acoustic ceiling coatings can greatly reduce noise levels in mechanical rooms.
- Mount unit on a sound absorbing pad, extruded polystyrene, rubber or cork pad.

Ductwork

- Ensure return air grilles will not allow line of site noise to transfer to adjacent space. Use a sound barrier or some other material to isolate the grille from the unit. A supply grille, boot and short piece of flex duct pointed away from the unit can greatly attenuate equipment noise.
- Use a canvas isolation duct connector at the supply and return duct connection of the unit.
- Internally line the discharge and return duct within the first 4-8 feet of unit with acoustic insulation. Install an internally lined 'L' shaped return duct elbow at return grille. Face the elbow away from adjacent units.
- Always install at least one 90° elbow in the discharge duct to eliminate line of sight noise transmission of the blower.
- Use turning vanes at all elbows and tees to reduce turbulence.
- Limit supply duct velocities to less than 1,000 fpm
- Design and install ductwork as stiff as possible
- Allow 3 duct diameters both up and down stream of the unit before any fittings or transitions are installed.
- Use duct sealant on all duct joints.
- Install a short (2-4') of flex duct on all branch ducts just prior to discharge boot or diffuser to reduce vibration and duct sound prior to delivery in the room.
- Locate the branch duct balancing damper as far away from the diffuser as possible.
- In ceiling plenum systems, install an internally lined 'L' shaped return duct elbow at unit. Face the elbow away from adjacent units (horizontal).

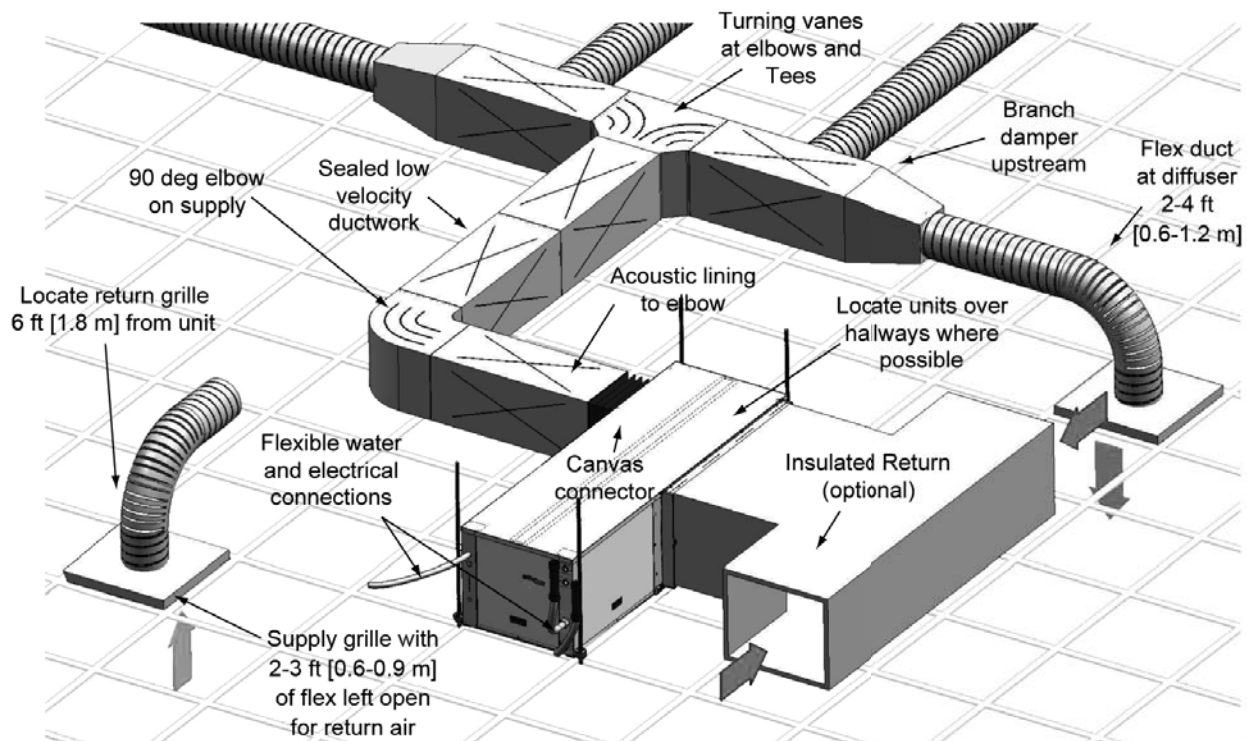

Vertical Dimensional Data

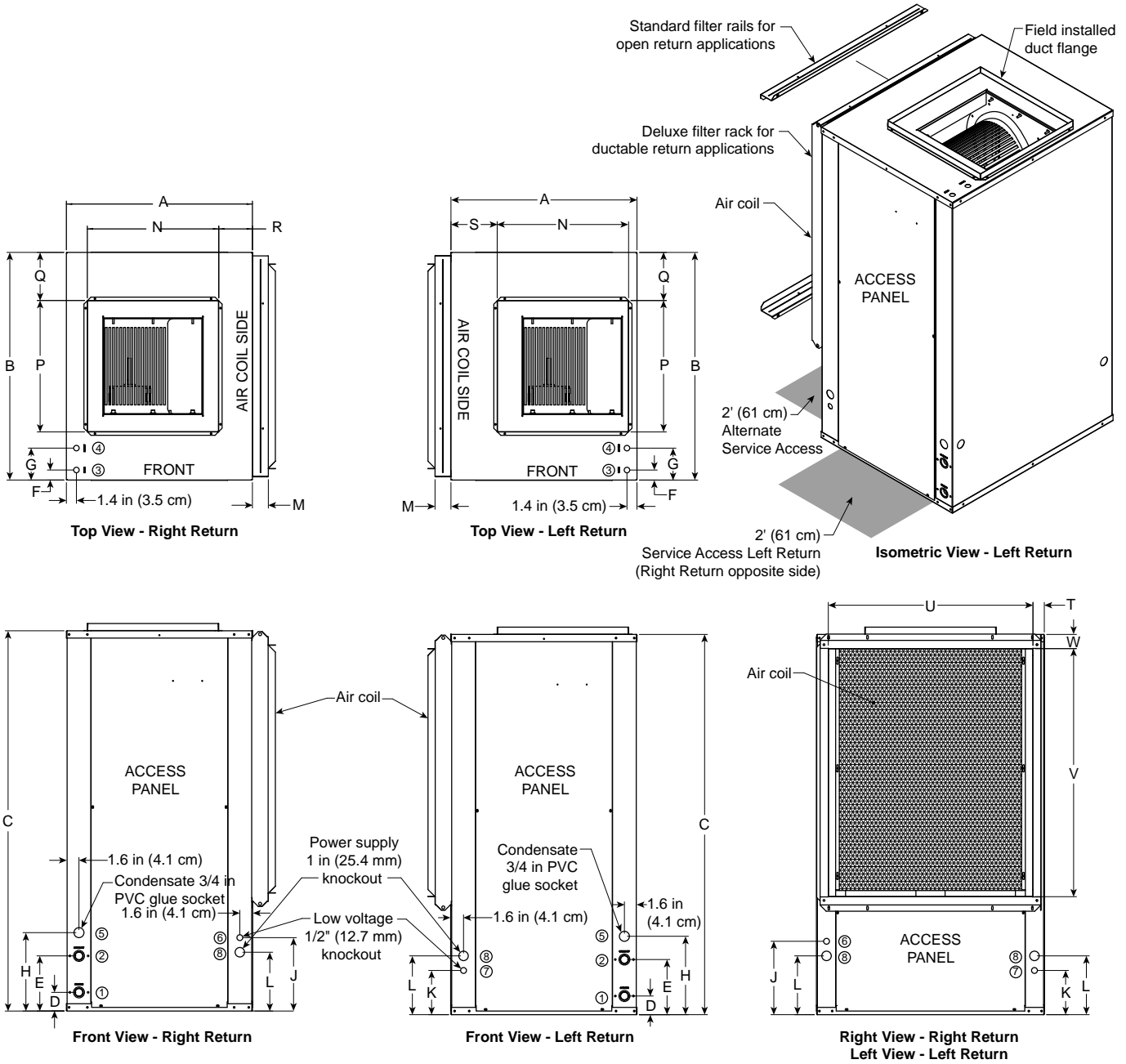

Vertical Dimensional Data cont.

Vertical Models	Overall Cabinet			Water Connections							Electrical Knockouts			
				1	2	3	4	5			6	7	8	
	A	B	C	D	E	F	G	H	Loop	Knockout	1/2 in. cond	1/2 in. cond	1 in. cond	
	Width	Depth	Height*	In	Out	HWG In	HWG Out	Condensate	Water FPT	HWG Provisions	Low Voltage	Low Voltage	Power Supply	
009-012	in.	22.5	22.2	30.2	2.6	7.6	N/A	N/A	10.8	1/2 in.	N/A	9.4	5.4	7.4
	cm.	57.2	56.4	76.7	6.6	19.3	N/A	N/A	27.4	12.7 mm	N/A	23.9	13.7	18.8
015-018	in.	22.5	26.2	40.2	2.6	7.6	1.4	4.4	10.8	3/4 in.	0.875	10.1	6.1	8.1
	cm.	57.2	66.5	102.1	6.6	19.3	3.6	11.2	27.4	19.1 mm	22.2 mm	25.7	15.5	20.6
024-030	in.	22.5	26.2	44.2	2.6	7.6	1.4	4.4	10.8	3/4 in.	0.875	10.1	6.1	8.1
	cm.	57.2	66.5	112.3	6.6	19.3	3.6	11.2	27.4	19.1 mm	22.2 mm	25.7	15.5	20.6
036-038	in.	25.5	31.2	44.2	2.6	7.6	1.4	4.4	10.8	1 in.	0.875	10.1	6.1	8.1
	cm.	64.8	79.2	112.3	6.6	19.3	3.6	11.2	27.4	25.4 mm	22.2 mm	25.7	15.5	20.6
042-049	in.	25.5	31.2	48.2	2.6	7.6	1.4	4.4	10.8	1 in.	0.875	10.1	6.1	8.1
	cm.	64.8	79.2	122.4	6.6	19.3	3.6	11.2	27.4	25.4 mm	22.2 mm	25.7	15.5	20.6
060-072	in.	25.5	31.2	52.2	2.6	7.6	1.4	4.4	10.8	1 in.	0.875	10.1	6.1	8.1
	cm.	64.8	79.2	132.6	6.6	19.3	3.6	11.2	27.4	25.4 mm	22.2 mm	25.7	15.5	20.6

3/16/12

Vertical Models		Discharge Connection duct flange installed (±0.10 in)						**Return Connection using deluxe filter rack (±0.10 in)			
		M	N	P	Q	R	S	T	U	V	W
		Filter Rack Width	Supply Width	Supply Depth					Return Depth	Return Height	
009-012	in.	2.2	10.0	10.0	6.1	5.3	9.8	2.0	18.1	14.0	2.0
	cm.	5.6	25.4	25.4	15.5	13.5	24.9	5.1	46.0	35.6	5.1
015-018	in.	2.2	14.0	14.0	6.1	4.5	7.7	2.0	22.1	22.0	1.9
	cm.	5.6	35.6	35.6	15.5	11.4	19.6	5.1	56.1	55.9	4.8
024-030	in.	2.2	14.0	14.0	6.1	4.5	7.7	2.0	22.1	26.1	1.8
	cm.	5.6	35.6	35.6	15.5	11.4	19.6	5.1	56.1	66.3	4.6
036-038	in.	2.2	18.0	18.0	6.6	4.6	6.3	1.6	28.1	26.1	2.0
	cm.	5.6	45.7	45.7	16.8	11.7	16.0	4.1	71.4	66.3	5.1
042-049	in.	2.2	18.0	18.0	6.6	4.6	6.3	1.6	28.1	30.0	2.0
	cm.	5.6	45.7	45.7	16.8	11.7	16.0	4.1	71.4	76.2	5.1
060-072	in.	2.2	18.0	18.0	6.6	5.0	6.4	1.6	28.1	34.0	2.0
	cm.	5.6	45.7	45.7	16.8	12.7	16.3	4.1	71.4	86.4	5.1

3/16/12

Condensate is 3/4 in. PVC female glue socket and is switchable from side to front.

*Discharge flange is field installed and extends 1 in. (25.4 mm) from top of cabinet.

****Vertical units shipped with standard 2 in. (field adjustable to 1 in.) open application filter rack extending 2.2 in. from unit and is not suitable for duct connection, for ductable return connection applications, order the deluxe 2 in. (field adjustable to 1 in.) duct collar/filter rack which extends 3.25 in. from the unit and is suitable for duct connections.**

Vertical Disconnect

When using disconnect, do not use dimension L from the standard vertical dimensional data. Use dimension LL from the vertical disconnect dimensional data.

Vertical Models	LL
009-012	17.8 [45.2]
015-018	14.3 [36.3]
024-030	15.3 [38.9]
036-038	14.3 [36.3]
042-049	14.3 [36.3]
060-064	14.3 [36.3]
070-072	External

Dimensions in inches [cm]

3/16/12

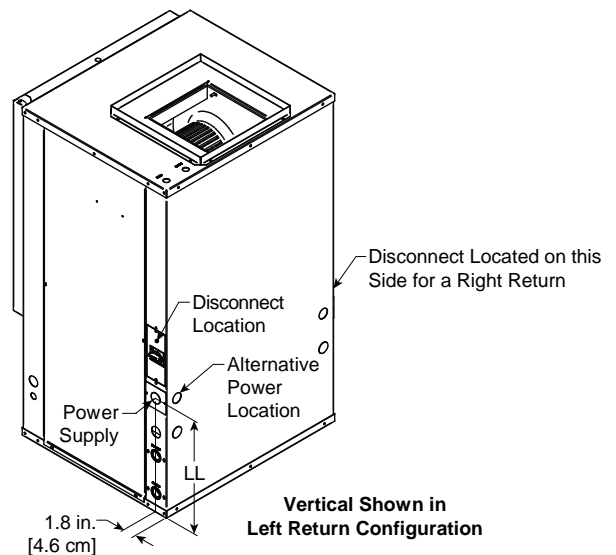

Horizontal Dimensional Data

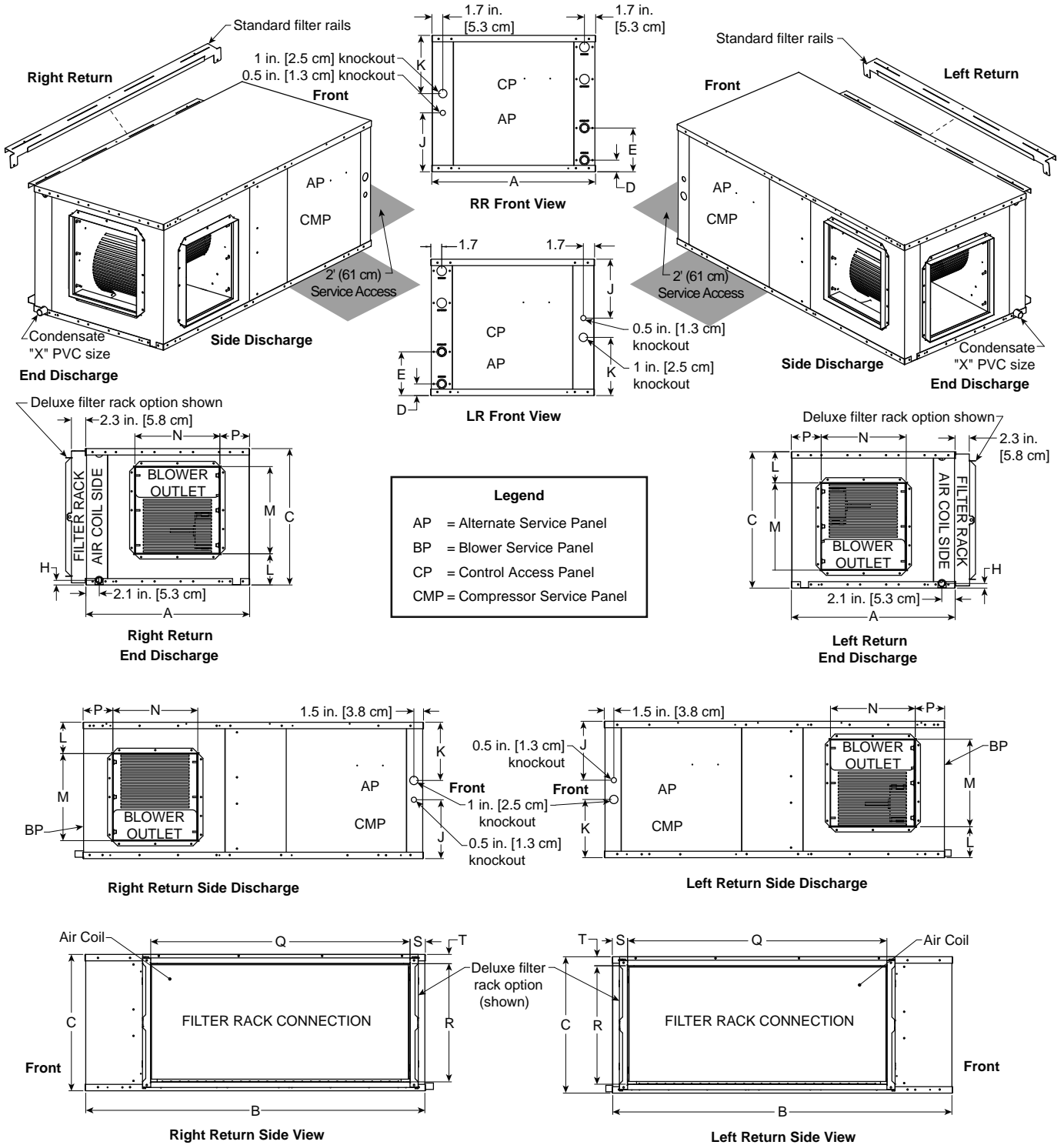

Horizontal Dimensional Data cont.

Horizontal Models	Overall Cabinet			Water Connections				Electrical Knockouts		
	A	B	C	1	2	3		J	K	
	Width	Depth	Height*	D	E	H	Loop	1/2 in. cond	1 in. cond	
			In	Out	Condensate	Water FPT	Low Voltage	Power Supply		
009-012	in.	22.5	35.0	17.2	1.8	6.8	0.8	1/2 in.	7.1	7.1
	cm.	57.2	88.9	43.7	4.6	17.3	2.0	12.7 mm	18.0	18.0
015-018	in.	22.5	42.0	19.2	1.8	6.8	0.8	3/4 in.	9.1	7.1
	cm.	57.2	106.7	48.8	4.6	17.3	2.0	19.05 mm	23.1	18.0
024-030	in.	22.5	45.0	19.2	1.8	6.8	0.8	3/4 in.	9.2	7.1
	cm.	57.2	114.3	48.8	4.6	17.3	2.0	19.05 mm	23.4	18.0
036-038	in.	25.5	48.0	21.2	1.8	6.8	0.8	1 in.	9.2	9.1
	cm.	64.8	121.9	53.8	4.6	17.3	2.0	25.4 mm	23.4	23.1
042-049	in.	25.5	53.0	21.2	1.8	6.8	0.8	1 in.	9.2	9.1
	cm.	64.8	134.6	53.8	4.6	17.3	2.0	25.4 mm	23.4	23.1
060-064	in.	25.5	61.0	21.2	1.8	6.8	0.8	1 in.	9.2	9.1
	cm.	64.8	154.9	53.8	4.6	17.3	2.0	25.4 mm	23.4	23.1
070-072	in.	25.5	68.0	21.2	1.8	6.8	0.8	1 in.	9.2	9.1
	cm.	64.8	172.7	53.8	4.6	17.3	2.0	25.4 mm	23.4	23.1

3/16/12

Horizontal Models	Discharge Connection duct flange installed (±0.10 in.)				Return Connection using deluxe filter rack option (±0.10 in.)				PVC Size	
	L	M	N	P	Q	R	S	T	X	
		Supply Width	Supply Depth		Return Depth	Return Height				
009-012	in.	5.9	7.2	9.5	6.0	16.4	14.5	2.0	1.4	3/4"
	cm.	15.0	18.3	24.1	15.2	41.7	36.8	5.1	3.6	1.9
015-018	in.	6.7	10.5	9.4	4.9	27.4	16.6	2.0	1.4	3/4"
	cm.	17.0	26.7	23.9	12.4	69.6	42.2	5.1	3.6	1.9
024-030	in.	6.7	10.5	9.4	4.9	30.4	16.6	2.0	1.5	3/4"
	cm.	17.0	26.7	23.9	12.4	77.2	42.2	5.1	3.8	1.9
036-038	in.	4.9	13.6	13.2	4.6	35.4	18.6	2.3	1.4	3/4"
	cm.	12.4	34.5	33.5	11.7	89.9	47.2	5.8	3.6	1.9
042-049	in.	4.9	13.6	13.2	4.6	40.4	18.6	2.3	1.4	3/4"
	cm.	12.4	34.5	33.5	11.7	102.6	47.2	5.8	3.6	1.9
060-064	in.	4.9	13.6	13.2	4.6	45.4	18.6	2.3	1.4	3/4"
	cm.	12.4	34.5	33.5	11.7	115.3	47.2	5.8	3.6	1.9
070-072	in.	4.9	13.6	13.2	4.6	45.4	18.6	2.3	1.4	3/4"
	cm.	12.4	34.5	33.5	11.7	115.3	47.2	5.8	3.6	1.9

3/16/12

Horizontal units shipped with standard 2 in. (field adjustable to 1 in.) open application filter rack extending 2.2 in. from unit and is not suitable for duct connection, for ductable return connection applications, order the deluxe 2 in. (field adjustable to 1 in.) filter rail/filter rack which extends 3.25 in. from the unit and is suitable for duct connections.

Horizontal Disconnect

When using disconnect, do not use dimension K from the standard horizontal dimensional data. Use dimension KK from the horizontal disconnect dimensional data.

Horizontal Models	KK
009-012	8.2 [20.8]
015-018	9.2 [23.4]
024-030	9.2 [23.4]
036-038	11.2 [28.4]
042-049	10.2 [25.9]
060-064	11.2 [28.4]
070-072	10.2 [25.9]

Dimensions in inches [cm]

3/16/12

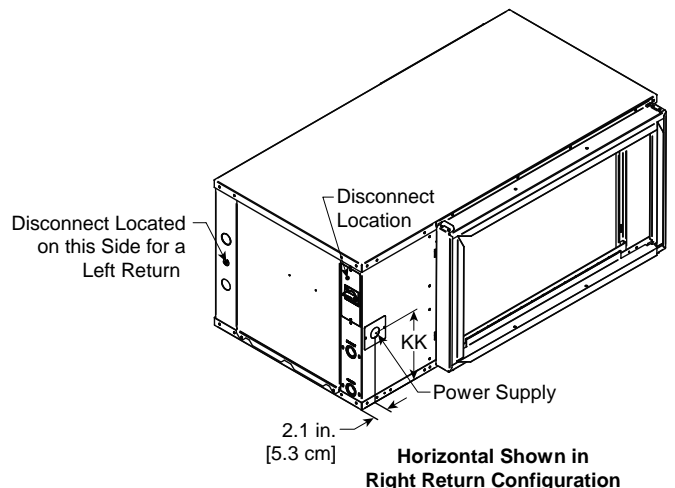

Hanger Bracket Locations

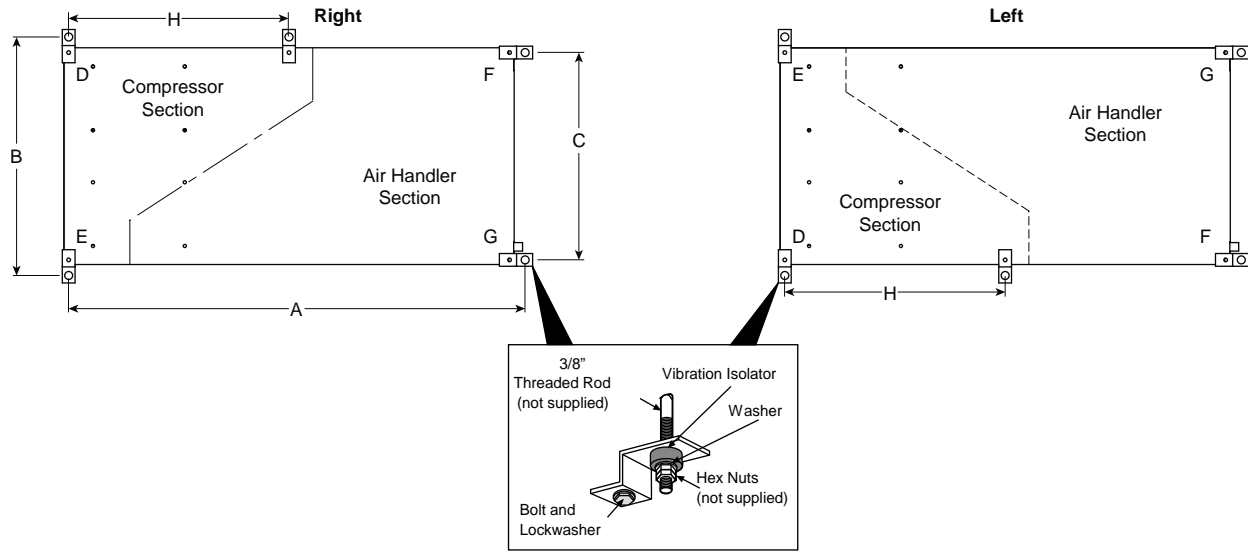

NOTE: Model sizes 070-072 will be shipped with six (6) hanger brackets. Only five (5) hanger brackets will be used on the unit. See the above illustration for the fifth hanger bracket location. All other models will use four (4) hanger brackets.

Hanger Bracket Dimensions

Model	Hanger Kit Part Number	Unit Hanger Dimensions					
		A	B	C	H		
Single Speed	009-012	in.	99S500A04	35.7	25.1	21.4	n/a
		cm.		90.7	63.8	54.4	n/a
	015-018	in.	99S500A04	42.8	25.1	21.4	n/a
		cm.		108.7	63.8	54.4	n/a
	024-030	in.	99S500A04	45.8	25.1	21.4	n/a
		cm.		116.3	63.8	54.4	n/a
	036	in.	99S500A04	48.8	28.1	24.4	n/a
		cm.		124.0	71.4	62.0	n/a
	042-048	in.	99S500A04	53.8	28.1	24.4	n/a
		cm.		136.7	71.4	62.0	n/a
	060	in.	99S500A04	61.8	28.1	24.4	n/a
		cm.		157.0	71.4	62.0	n/a
070	in.	99S500A03	68.8	28.1	24.4	34.0	
	cm.		174.8	71.4	62.0	74.4	
Dual Capacity	026	in.	99S500A04	45.8	25.1	21.4	n/a
		cm.		116.3	63.8	54.4	n/a
	038	in.	99S500A03	48.8	28.1	24.4	n/a
		cm.		124.0	71.4	62.0	n/a
	049	in.	99S500A04	53.8	28.1	24.4	n/a
		cm.		136.7	71.4	62.0	n/a
	064	in.	99S500A04	61.8	28.1	24.4	n/a
		cm.		157.0	71.4	62.0	n/a
	072	in.	99S500A03	68.8	28.1	24.4	34.0
		cm.		174.8	71.4	62.0	74.4

3/16/12

Weight Distribution

Model	Vertical Weight	Horizontal Weight	Horizontal Weight Distribution				
			Front		Back		
			D	E	F	G	
Single Speed	009	171	176	32	67	32	45
		[78]	[80]	[15]	[30]	[15]	[20]
	012	171	176	32	67	32	45
		[78]	[80]	[15]	[30]	[15]	[20]
	015	210	220	65	40	70	35
		[95]	[100]	[29]	[18]	[32]	[16]
	018	210	220	65	40	70	35
		[95]	[100]	[29]	[18]	[32]	[16]
	024	280	295	75	70	75	20
		[127]	[134]	[34]	[31]	[34]	[13]
	030	285	295	75	70	75	30
		[129]	[134]	[34]	[31]	[34]	[13]
036	300	305	85	80	85	40	
	[136]	[138]	[39]	[36]	[39]	[18]	
042	365	375	115	95	75	60	
	[166]	[170]	[52]	[43]	[34]	[27]	
048	370	380	120	100	80	65	
	[168]	[172]	[54]	[45]	[36]	[29]	
060	410	420	120	110	95	80	
	[186]	[191]	[54]	[50]	[43]	[36]	
070	445	455	135	120	100	85	
	[202]	[206]	[61]	[54]	[45]	[39]	
Dual Capacity	026	280	295	75	70	75	50
		[127]	[134]	[34]	[31]	[34]	[13]
	038	360	375	115	95	75	60
		[163]	[170]	[52]	[43]	[34]	[27]
	049	370	380	120	100	80	65
		[168]	[172]	[54]	[45]	[36]	[29]
	064	410	420	120	110	95	80
		[186]	[191]	[54]	[50]	[43]	[36]
	072	445	455	135	120	100	85
		[202]	[206]	[61]	[54]	[45]	[39]

Weights are listed in lbs. [kg].

3/16/12

Physical Data

Model		Single Speed										
		009	012	015	018	024	030	036	042	048	060	070
Compressor (1 each)		Rotary					Scroll					
Factory Charge R-410A, oz [kg]	Vertical	29 [0.82]	36 [1.02]	38 [1.08]	48 [1.36]	56 [1.59]	68 [1.93]	84 [2.38]	86 [2.44]	92 [2.61]	100 [2.83]	128 [3.63]
Factory Charge R-410A, oz [kg]	Horizontal	29 [0.82]	36 [1.02]	42 [1.19]	42 [1.19]	54 [1.53]	64 [1.81]	78 [2.21]	84 [2.38]	92 [2.61]	84 [2.38]	118 [3.35]
Blower Motor & Blower												
Blower Motor Type/Speeds	VS ECM	Not Available			Variable Speed ECM							
	5-Spd ECM	Not Available			5-Speed ECM							
	PSC	PSC 4 Speeds			PSC - 3 Speeds							
Blower Motor, hp [W]	VS ECM	Not Available		1/2 [373]	1/2 [373]	1/2 [373]	1/2 [373]	1/2 [373]	1/2 [373]	1/2 [373]	1 [746]	1 [746]
	5-Spd ECM	Not Available		1/2 [373]	1/2 [373]	1/2 [373]	1/2 [373]	1/2 [373]	1 [746]	1 [746]	1 [746]	1 [746]
	PSC	1/10 [75]	1/10 [75]	1/6 [134]	1/6 [134]	1/5 [149]	1/3 [249]	1/2 [373]	1/2 [373]	1/2 [373]	1 [746]	1 [746]
Oversized PSC Blower Motor, hp [W]	VS ECM	Not Available					1 [746]	1 [746]	Not Available			
Blower Wheel Size (Dia x W), in. [mm]	VS ECM	Not Available		9 x 7 [229 x 178]	9 x 7 [229 x 178]	9 x 7 [229 x 178]	9 x 7 [229 x 178]	11 x 10 [279 x 254]	11 x 10 [279 x 254]	11 x 10 [279 x 254]	11 x 10 [279 x 254]	11 x 10 [279 x 254]
	5-Spd ECM	Not Available		9 x 7 [229 x 178]	9 x 7 [229 x 178]	9 x 7 [229 x 178]	9 x 7 [229 x 178]	11 x 10 [279 x 254]	11 x 10 [279 x 254]	11 x 10 [279 x 254]	11 x 10 [279 x 254]	11 x 10 [279 x 254]
	PSC	6 x 8 [152 x 203]	6 x 8 [152 x 203]	9 x 7 [229 x 178]	9 x 7 [229 x 178]	9 x 7 [229 x 178]	9 x 7 [229 x 178]	10 x 10 [254 x 254]	10 x 10 [254 x 254]	10 x 10 [254 x 254]	11 x 10 [279 x 254]	11 x 10 [279 x 254]
Oversized Blower Wheel Size (Dia x W), in. [mm]	VS ECM	Not Available						11 x 10 [279 x 254]	11 x 10 [279 x 254]	11 x 10 [279 x 254]	Not Available	
	PSC	Not Available				9 x 7 [229 x 178]	9 x 7 [229 x 178]	10 x 10 [254 x 254]	10 x 10 [254 x 254]	10 x 10 [254 x 254]	Not Available	
Coax and Water Piping												
Water Connections Size - FPT - in. [mm]		1/2 [12.7]	1/2 [12.7]	3/4 [19.05]	3/4 [19.05]	3/4 [19.05]	3/4 [19.05]	1 [25.4]	1 [25.4]	1 [25.4]	1 [25.4]	1 [25.4]
HWG Connection Size - Female Sweat I.D. - in [mm] (Vertical Only)		Not Available			1/2 [12.7]	1/2 [12.7]	1/2 [12.7]	1/2 [12.7]	1/2 [12.7]	1/2 [12.7]	1/2 [12.7]	1/2 [12.7]
Coax and Piping Water Volume - gal [l]		0.26 [0.98]	0.3 [1.12]	0.4 [1.49]	0.4 [1.49]	0.4 [1.49]	0.75 [2.83]	0.9 [3.41]	0.9 [3.41]	1.25 [4.72]	1.5 [5.68]	1.5 [5.68]
Vertical												
Air Coil Dimensions (H x W), in. [mm]		12 x 16 [305 x 406]	16 x 16 [406 x 406]	19 x 20 [483 x 508]	19 x 20 [483 x 508]	24 x 20 [610 x 508]	28 x 20 [711 x 508]	28 x 25 [711 x 635]	32 x 25 [813 x 635]	32 x 25 [813 x 635]	36 x 25 [914 x 635]	36 x 25 [914 x 635]
Air Coil Total Face Area, ft ² [m ²]		1.3 [0.121]	1.8 [0.167]	2.6 [0.242]	2.6 [0.242]	3.3 [0.307]	3.9 [0.362]	4.9 [0.455]	5.6 [0.520]	5.6 [0.520]	6.3 [0.585]	6.3 [0.585]
Air Coil Tube Size, in [mm]		5/16 [7.9]	3/8 [9.5]	5/16 [7.9]	5/16 [7.9]	3/8 [9.5]	3/8 [9.5]	3/8 [9.5]	3/8 [9.5]	3/8 [9.5]	3/8 [9.5]	3/8 [9.5]
Air Coil Number of rows		3	3	3	3	3	3	3	3	3	4	4
Filter Standard - 1 in. [25mm] Pleated MERV 4 Throwaway, in [mm]		1-16 x 20 [406 x 508]	1-16 x 18 [406 x 457]	1-24 x 24 [610 x 610]	1-24 x 24 [610 x 610]	28 x 24 [712 x 610]	28 x 24 [712 x 610]	28 x 30 [712 x 762]	32 x 30 [813 x 762]	32 x 30 [813 x 762]	30 x 36 [762 x 914]	30 x 36 [762 x 914]
Filter Standard - 2 in. [51mm] Pleated MERV 13 Throwaway, in [mm]		1-16 x 20 [406 x 508]	1-16 x 18 [406 x 457]	1-24 x 24 [610 x 610]	1-24 x 24 [610 x 610]	28 x 24 [712 x 610]	28 x 24 [712 x 610]	28 x 30 [712 x 762]	32 x 30 [813 x 762]	32 x 30 [813 x 762]	30 x 36 [762 x 914]	30 x 36 [762 x 914]
Horizontal												
Air Coil Dimensions (H x W), in. [mm]		12 x 16 [305 x 406]	16 x 16 [406 x 406]	18 x 21 [457 x 533]	18 x 21 [457 x 533]	18 x 27 [457 x 686]	18 x 30 [457 x 762]	20 x 35 [508 x 889]	20 x 40 [508 x 1016]	20 x 40 [508 x 1016]	20 x 45 [508 x 1143]	20 x 45 [508 x 1143]
Air Coil Total Face Area, ft ² [m ²]		1.3 [0.121]	1.8 [0.167]	2.6 [0.242]	2.6 [0.242]	3.4 [0.316]	3.8 [0.353]	4.9 [0.455]	5.6 [0.520]	5.6 [0.520]	6.3 [0.585]	6.3 [0.585]
Air Coil Tube Size, in. [mm]		5/16 [7.9]	3/8 [9.5]	5/16 [7.9]	5/16 [7.9]	3/8 [9.5]	3/8 [9.5]	3/8 [9.5]	3/8 [9.5]	3/8 [9.5]	3/8 [9.5]	3/8 [9.5]
Air Coil Number of rows		3	3	3	3	3	3	3	3	3	3	3
Filter Standard - 1 in. [25mm] Pleated MERV 4 Throwaway, in. [mm]		1-16 x 18 [406 x 508]	1-16 x 18 [406 x 508]	2-18 x 14 [457 x 356]	2-18 x 14 [457 x 356]	1-18 x 18 [457 x 457] 1-18 x 14 [457 x 356]	1-18 x 18 [457 x 457] 1-18 x 14 [457 x 356]	2-18 x 20 [457 x 508]	1-20 x 20 [508 x 508] 1-20 x 22 [508 x 559]	1-20 x 20 [508 x 508] 1-20 x 22 [508 x 559]	1-20 x 25 [508 x 635] 1-20 x 22 [508 x 559]	1-20 x 25 [508 x 635] 1-20 x 22 [508 x 559]
Filter Standard - 2 in. [51mm] Pleated MERV 13 Throwaway, in. [mm]		1-16 x 18 [406 x 508]	1-16 x 18 [406 x 508]	1-18 x 29 [457 x 737]	1-18 x 29 [457 x 737]	1-18 x 32 [457 x 813]	1-18 x 32 [457 x 813]	1-20 x 37 [686 x 940]	1-20 x 20 [508 x 508] 1-20 x 22 [508 x 559]	1-20 x 20 [508 x 508] 1-20 x 22 [508 x 559]	1-20 x 25 [508 x 635] 1-20 x 22 [508 x 559]	1-20 x 25 [508 x 635] 1-20 x 22 [508 x 559]

Physical Data cont.

Model		Dual Capacity				
		026	038	049	064	072
Compressor (1 each)		Copeland 2-speed Scroll, UltraTech				
Factory Charge R410-A, oz [kg]	Vertical	56 [1.59]	78 [2.21]	93 [2.64]	104 [2.95]	128 [3.63]
Factory Charge R410-A, oz [kg]	Horizontal	52 [1.47]	74 [2.10]	93 [2.64]	118 [3.35]	138 [3.91]
Variable Speed ECM Blower Motor and Blower		Variable Speed ECM				
Blower Motor Type/Speeds		5-Speed ECM				
Blower Motor- hp [W]	VS ECM	1/2 [373]	1/2 [373]	1/2 [373]	1 [746]	1 [746]
	5-Spd ECM	1/2 [373]	1/2 [373]	1 [746]	1 [746]	1 [746]
Over sized Blower Motor- hp [W]	VS ECM	not available	1 [746]	1 [746]	Not Available	Not Available
Blower Wheel Size (Dia x W), in. [mm]	VS ECM	9 x 7 [229 x 178]	11 x 10 [279 x 254]	11 x 10 [279 x 254]	11 x 10 [279 x 254]	11 x 10 [279 x 254]
Blower Wheel Size (Dia x W), in. [mm]	5-Spd ECM	9 x 7 [229 x 178]	11 x 10 [279 x 254]	11 x 10 [279 x 254]	11 x 10 [279 x 254]	11 x 10 [279 x 254]
Over sized Blower Wheel Size (Dia x W), in. [mm]	VS ECM	Not Available	11 x 10 [279 x 254]	11 x 10 [279 x 254]	Not Available	Not Available
Coax and Water Piping						
Water Connections Size - FPT - in [mm]		3/4 [19.05]	1 [25.4]	1 [25.4]	1 [25.4]	1 [25.4]
HWG Connection Size - Female Sweat I.D. - in. [mm] (Vertical Only)		1/2 [12.7]	1/2 [12.7]	1/2 [12.7]	1/2 [12.7]	1/2 [12.7]
Coax and Piping Water Volume - gal [l]		0.7 [2.6]	1.3 [4.9]	1.6 [6.1]	1.6 [6.1]	2.3 [8.7]
Vertical						
Air Coil Dimensions (H x W), in. [mm]		24 x 20 [610 x 508]	28 x 25 [711 x 635]	32 x 25 [813 x 635]	36 x 25 [914 x 635]	36 x 25 [914 x 635]
Air Coil Total Face Area, ft ² [m ²]		3.3 [0.307]	4.9 [0.451]	5.6 [0.520]	6.3 [0.585]	6.3 [0.585]
Air Coil Tube Size, in. [mm]		3/8 [9.5]	3/8 [9.5]	3/8 [9.5]	3/8 [9.5]	3/8 [9.5]
Air Coil Number of rows		3	3	3	4	4
Filter Standard - 1 in. [25mm] Pleated MERV 4 Throwaway, in. [mm]		28 x 24 [712 x 610]	28 x 30 [711 x 762]	32 x 30 [813 x 762]	36 x 30 [914 x 762]	30 x 36 [762 x 914]
Filter Standard - 2 in. [51mm] Pleated MERV 13 Throwaway, in. [mm]		28 x 24 [712 x 610]	28 x 30 [711 x 762]	32 x 30 [813 x 762]	30 x 36 [762 x 914]	30 x 36 [762 x 914]
Horizontal						
Air Coil Dimensions (H x W), in. [mm]		18 x 27 [457 x 686]	20 x 35 [508 x 889]	20 x 40 [508 x 1016]	20 x 45 [508 x 1143]	20 x 45 [508 x 1143]
Air Coil Total Face Area, ft ² [m ²]		3.4 [0.316]	4.9 [0.451]	5.6 [0.520]	6.3 [0.585]	6.3 [0.585]
Air Coil Tube Size, in. [mm]		3/8 [9.5]	3/8 [9.5]	3/8 [9.5]	3/8 [9.5]	3/8 [9.5]
Air Coil Number of rows		3	3	3	4	4
Filter Standard - 1 in. [25mm] Pleated MERV 4 Throwaway, in. [mm]		1 - 18 x 18 [457 x 457] 1 - 18 x 14 [457 x 356]	2 - 18 x 20 [457 x 508]	1 - 20 x 22 [508 x 559] 1 - 20 x 20 [508 x 508]	1 - 20 x 25 [508 x 635] 1 - 20 x 22 [508 x 559]	1 - 20 x 25 [508 x 635] 1 - 20 x 22 [508 x 559]
Filter Standard - 2 in. [51mm] Pleated MERV 13 Throwaway, in. [mm]		1 - 18 x 32 [457 x 813]	1 - 20 x 37 [508 x 940]	1 - 20 x 20 [508 x 508] 1 - 20 x 22 [508 x 559]	1 - 20 x 25 [508 x 635] 1 - 20 x 22 [508 x 559]	1 - 20 x 25 [508 x 635] 1 - 20 x 22 [508 x 559]

4/11/14

Electrical Availability

PSC

Voltage	Static Option	Single Speed Models											Dual Capacity Models				
		009	012	015	018	024	030	036	042	048	060	070	026	038	049	064	072
208-230/60/1	Standard					
208-230/60/1 w/IntelliStart									
265/60/1										
208-230/60/3 (also w/IntelliStart)										
460/60/3 (also w/IntelliStart)										
575/60/3									.		.	.					
208-230/60/1 (also w/IntelliStart)	High											
265/60/1						.	.	.									
208-230/60/3 (also w/IntelliStart)												
460/60/3 (also w/IntelliStart)												
575/60/3									.	.							

1/2/13

5-Speed ECM

Voltage	Static Option	Single Speed Models									Dual Capacity Models				
		015	018	024	030	036	042	048	060	070	026	038	049	064	072
208-230/60/1	Standard
208-230/60/1 w/IntelliStart		
265/60/1				
208-230/60/3 (also w/IntelliStart)			
460/60/3 (also w/IntelliStart)			
575/60/3															

1/2/13

Variable Speed ECM

Voltage	Static Option	Single Speed Models									Dual Capacity Models				
		015	018	024	030	036	042	048	060	070	026	038	049	064	072
208-230/60/1	Standard
208-230/60/1 w/IntelliStart		
265/60/1				
208-230/60/3 (also w/IntelliStart)			
460/60/3 (also w/IntelliStart)			
575/60/3															
208-230/60/1	High						
265/60/1						.						.			
208-230/60/3 (also w/IntelliStart)							
460/60/3 (also w/IntelliStart)							
575/60/3															

1/2/13

Electrical Data

PSC Motor

Model	Rated Voltage	Voltage Min/Max	Compressor				Blower Motor FLA	Total Unit FLA	Min Circ Amp	Max Fuse/HACR Breaker	
			MCC	RLA	LRA	LRA**					
Single Speed	009	208-230/60/1	187/253	6.4	4.1	21.0	n/a	0.6	4.7	5.7	10/15
		265/60/1	238/292	6.7	4.3	22.0	n/a	0.6	4.9	6.0	10/15
	012	208-230/60/1	187/253	7.7	4.9	25.0	n/a	0.6	5.5	6.7	10/15
		265/60/1	238/292	7.0	4.5	22.0	n/a	0.6	5.1	6.2	10/15
	015	208-230/60/1	187/253	9.7	6.2	29.0	n/a	1.1	7.3	8.9	15
		265/60/1	238/292	7.8	5.0	28.0	n/a	1.0	6.0	7.3	10/15
	018	208-230/60/1	187/253	13.1	8.4	33.5	13.4	1.1	9.5	11.6	20
		265/60/1	238/292	8.7	5.6	28.0	n/a	1.0	6.6	8.0	10/15
	024	208-230/60/1	187/253	21.0	13.5	58.3	23.3	1.2	14.7	18.1	25
		265/60/1	238/292	14.0	9.0	54.0	n/a	1.1	10.1	12.4	20
		208-230/60/3	187/253	11.0	7.1	55.4	33.2	1.2	8.3	10.1	15
		460/60/3	414/506	5.5	3.5	28.0	16.8	0.6	4.1	5.0	10/15
	024*	208-230/60/1	187/253	21.0	13.5	58.3	23.3	1.5	15.0	18.4	30
		265/60/1	238/292	14.0	9.0	54.0	n/a	1.5	10.5	12.8	20
		208-230/60/3	187/253	11.0	7.1	55.4	33.2	1.5	8.6	10.4	15
		460/60/3	414/506	5.5	3.5	28.0	16.8	1.0	4.5	5.4	10/15
	030	208-230/60/1	187/253	20.0	12.8	58.0	23.2	1.5	14.3	17.5	30
		265/60/1	238/292	15.0	9.6	54.0	n/a	1.5	11.1	13.5	20
		208-230/60/3	187/253	12.0	7.7	55.4	33.2	1.5	9.2	11.1	15
		460/60/3	414/506	5.6	3.6	28.0	16.8	1.0	4.6	5.5	10/15
030*	208-230/60/1	187/253	20.0	12.8	58.0	23.2	2.8	15.6	18.8	30	
	265/60/1	238/292	15.0	9.6	54.0	n/a	2.0	11.6	14.0	20	
	208-230/60/3	187/253	12.0	7.7	55.4	33.2	2.2	9.9	11.8	15	
	460/60/3	414/506	5.6	3.6	28.0	16.8	1.1	4.7	5.6	10/15	
036	208-230/60/1	187/253	22.0	14.1	73.0	29.2	2.8	16.9	20.4	30	
	265/60/1	238/292	17.5	11.2	60.0	n/a	2.0	13.2	16.0	25	
	208-230/60/3	187/253	13.9	8.9	58.0	34.8	2.8	11.7	13.9	20	
	460/60/3	414/506	6.5	4.2	28.0	16.8	1.4	5.6	6.7	10/15	
036*	208-230/60/1	187/253	22.0	14.1	73.0	29.2	3.5	17.6	21.1	35	
	265/60/1	238/292	17.5	11.2	60.0	n/a	3.5	14.7	17.5	25	
	208-230/60/3	187/253	13.9	8.9	58.0	34.8	1.8	10.7	12.9	20	
	460/60/3	414/506	6.5	4.2	28.0	16.8	1.8	5.6	6.7	10/15	
042	208-230/60/1	187/253	26.0	16.7	79.0	31.6	3.5	20.2	24.4	40	
	208-230/60/3	187/253	16.3	10.4	73.0	43.8	3.5	13.9	16.5	25	
	460/60/3	414/506	9.0	5.8	38.0	22.8	1.8	7.6	9.0	10/15	
	575/60/3	517/633	5.9	3.8	36.5	n/a	1.4	5.2	6.1	10/15	
042*	208-230/60/1	187/253	26.0	16.7	79.0	31.6	4.6	21.3	25.5	40	
	208-230/60/3	187/253	16.3	10.4	73.0	43.8	4.6	15.0	17.6	25	
	460/60/3	414/506	9.0	5.8	38.0	22.8	2.3	8.1	9.5	15	
	575/60/3	517/633	5.9	3.8	36.5	n/a	1.9	5.7	6.6	10/15	
048	208-230/60/1	187/253	31.0	19.9	109.0	43.6	3.5	23.4	28.4	45	
	208-230/60/3	187/253	21.2	13.6	83.1	49.9	3.5	17.1	20.5	30	
	460/60/3	414/506	9.5	6.1	41.0	24.6	1.8	7.9	9.4	15	
	575/60/3	517/633	6.5	4.2	33.0	n/a	1.4	5.6	6.7	10/15	
048*	208-230/60/1	187/253	31.0	19.9	109.0	43.6	4.6	24.5	29.5	45	
	208-230/60/3	187/253	21.2	13.6	83.1	49.9	4.6	18.2	21.6	35	
	460/60/3	414/506	9.5	6.1	41.0	24.6	2.3	8.4	9.9	15	
	575/60/3	517/633	6.5	4.2	33.0	n/a	1.9	6.1	7.2	10/15	
060	208-230/60/1	187/253	41.2	26.4	134.0	53.6	5.9	32.3	38.9	60	
	208-230/60/3	187/253	24.9	16.0	110.0	66.0	5.9	21.9	25.9	40	
	460/60/3	414/506	12.1	7.8	52.0	31.2	3.0	10.8	12.8	20	
	575/60/3	517/633	8.9	5.7	38.9	n/a	1.9	7.6	9.0	10/15	
070	208-230/60/1	187/253	44.2	28.3	178.0	71.2	5.9	34.2	41.3	70	
	208-230/60/3	187/253	30.0	19.2	136.0	81.6	5.9	25.1	29.9	45	
	460/60/3	414/506	13.6	8.7	66.1	39.7	3.0	11.7	13.9	20	
	575/60/3	517/633	10.7	6.9	55.3	n/a	1.9	8.8	10.5	15	

HACR circuit breaker in USA only
 *With optional High-static PSC motor
 **With optional IntelliStart

Electrical Data cont.

5-Speed ECM Motor

Model	Rated Voltage	Voltage Min/Max	Compressor				Blower Motor FLA	Total Unit FLA	Min Circ Amp	Max Fuse/HACR Breaker	
			MCC	RLA	LRA	LRA**					
Single Speed	015	208-230/60/1	187/253	9.7	6.2	29.0	n/a	4.1	10.3	11.9	15
		265/60/1	238/292	7.8	5.0	28.0	n/a	3.6	8.6	9.9	10/15
	018	208-230/60/1	187/253	13.1	8.4	33.5	13.4	4.1	12.5	14.6	20
		265/60/1	238/292	8.7	5.6	28.0	n/a	3.6	9.2	10.6	15
	024	208-230/60/1	187/253	21.0	13.5	58.3	23.3	4.1	17.6	21.0	30
		265/60/1	238/292	14.0	9.0	54.0	n/a	3.6	12.6	14.9	20
		208-230/60/3	187/253	11.0	7.1	55.4	33.2	4.1	11.2	13.0	20
		460/60/3	414/506	5.5	3.5	28.0	16.8	2.1	5.6	6.5	10/15
	030	208-230/60/1	187/253	20.0	12.8	58.0	23.2	4.1	16.9	20.1	30
		265/60/1	238/292	15.0	9.6	54.0	n/a	3.6	13.2	15.6	25
		208-230/60/3	187/253	12.0	7.7	55.4	33.2	4.1	11.8	13.7	20
		460/60/3	414/506	5.6	3.6	28.0	16.8	2.1	5.7	6.6	10/15
	036	208-230/60/1	187/253	22.0	14.1	73.0	29.2	4.1	18.2	21.7	35
		265/60/1	238/292	17.5	11.2	60.0	n/a	3.6	14.8	17.6	25
		208-230/60/3	187/253	13.9	8.9	58.0	34.8	4.1	13.0	15.2	20
		460/60/3	414/506	6.5	4.2	28.0	16.8	2.1	6.3	7.4	10/15
	042	208-230/60/1	187/253	26.0	16.7	79.0	31.6	7.6	24.3	28.5	45
		208-230/60/3	187/253	16.3	10.4	73.0	43.8	7.6	18.0	20.6	30
		460/60/3	414/506	9.0	5.8	38.0	22.8	4.0	9.8	11.2	15
	048	208-230/60/1	187/253	31.0	19.9	109.0	43.6	7.6	27.5	32.5	50
		208-230/60/3	187/253	21.2	13.6	83.1	49.9	7.6	21.2	24.6	35
		460/60/3	414/506	9.5	6.1	41.0	24.6	4.0	10.1	11.6	15
	060	208-230/60/1	187/253	41.2	26.4	134.0	53.6	7.6	34.0	40.6	60
		208-230/60/3	187/253	24.9	16.0	110.0	66.0	7.6	23.6	27.6	40
460/60/3		414/506	12.1	7.8	52.0	31.2	4.0	11.8	13.8	20	
070	208-230/60/1	187/253	44.2	28.3	178.0	71.2	7.6	35.9	43.0	70	
	208-230/60/3	187/253	30.0	19.2	136.0	81.6	7.6	26.8	31.6	50	
	460/60/3	414/506	13.6	8.7	66.1	39.7	4.0	12.7	14.9	20	
Dual Capacity	026	208-230/60/1	187/253	18.2	11.7	58.3	23.3	4.1	15.8	18.7	30
		265/60/1	238/292	14.2	9.1	54.0	n/a	3.6	12.7	15.0	20
		208-230/60/3	187/253	10.1	6.5	55.4	33.2	4.1	10.6	12.2	15
		460/60/3	414/506	5.4	3.5	28.0	16.8	2.1	5.6	6.4	10/15
	038	208-230/60/1	187/253	23.8	15.3	83.0	33.2	4.1	19.4	23.2	35
		265/60/1	238/292	20.3	13.0	72.0	n/a	3.6	16.6	19.9	30
		208-230/60/3	187/253	18.1	11.6	73.0	43.8	4.1	15.7	18.6	30
		460/60/3	414/506	8.9	5.7	38.0	22.8	2.1	7.8	9.2	10/15
	049	208-230/60/1	187/253	33.0	21.1	104.0	41.6	7.6	28.7	34.0	50
		208-230/60/3	187/253	21.9	14.0	83.1	49.9	7.6	21.6	25.1	35
		460/60/3	414/506	10.0	6.4	41.0	24.6	4.0	10.4	12.0	15
	064	208-230/60/1	187/253	42.3	27.1	152.9	61.2	7.6	34.7	41.5	60
		208-230/60/3	187/253	25.8	16.5	110.0	66.0	7.6	24.1	28.2	40
		460/60/3	414/506	11.3	7.2	52.0	31.2	4.0	11.2	13.0	20
	072	208-230/60/1	187/253	46.3	29.7	179.2	71.7	7.6	37.3	44.7	70
		208-230/60/3	187/253	27.4	17.6	136.0	81.6	7.6	25.2	29.6	45
		460/60/3	414/506	13.2	8.5	66.1	39.7	4.0	12.5	14.6	20

HACR circuit breaker in USA only

**With optional IntelliStart

5/21/13

Electrical Data cont.

Variable Speed ECM Motor

Model	Rated Voltage	Voltage Min/Max	Compressor				Blower Motor FLA	Total Unit FLA	Min Circ Amp	Max Fuse/HACR Breaker	
			MCC	RLA	LRA	LRA**					
Single Speed	015	208-230/60/1	187/253	9.7	6.2	29.0	n/a	4.0	10.2	11.8	15
		265/60/1	238/292	7.8	5.0	28.0	n/a	4.1	9.1	10.4	15
	018	208-230/60/1	187/253	13.1	8.4	33.5	13.4	4.0	12.4	14.5	20
		265/60/1	238/292	8.7	5.6	28.0	n/a	4.1	9.7	11.1	15
	024	208-230/60/1	187/253	21.0	13.5	58.3	23.3	4.0	17.5	20.9	30
		265/60/1	238/292	14.0	9.0	54.0	n/a	4.1	13.1	15.4	20
		208-230/60/3	187/253	11.0	7.1	55.4	33.2	4.0	11.1	12.9	20
	030	460/60/3	414/506	5.5	3.5	28.0	16.8	4.1	7.6	8.5	10/15
		208-230/60/1	187/253	20.0	12.8	58.0	23.2	4.0	16.8	20.0	30
		265/60/1	238/292	15.0	9.6	54.0	n/a	4.1	13.7	16.1	25
		208-230/60/3	187/253	12.0	7.7	55.4	33.2	4.0	11.7	13.6	20
	036	460/60/3	414/506	5.6	3.6	28.0	16.8	4.1	7.7	8.6	10/15
		208-230/60/1	187/253	22.0	14.1	73.0	29.2	4.0	18.1	21.6	35
		265/60/1	238/292	17.5	11.2	60.0	n/a	4.1	15.3	18.1	25
		208-230/60/3	187/253	13.9	8.9	58.0	34.8	4.0	12.9	15.1	20
	036*	460/60/3	414/506	6.5	4.2	28.0	16.8	4.1	8.3	9.4	10/15
		208-230/60/1	187/253	22.0	14.1	73.0	29.2	7.0	21.1	24.6	35
		265/60/1	238/292	17.5	11.2	60.0	n/a	6.9	18.1	20.9	30
		208-230/60/3	187/253	13.9	8.9	58.0	34.8	7.0	15.9	18.1	25
	042	460/60/3	414/506	6.5	4.2	28.0	16.8	6.9	11.1	12.2	15
		208-230/60/1	187/253	26.0	16.7	79.0	31.6	4.0	20.7	24.9	40
		208-230/60/3	187/253	16.3	10.4	73.0	43.8	4.0	14.4	17.0	25
		460/60/3	414/506	9.0	5.8	38.0	22.8	4.1	9.9	11.3	15
	042*	208-230/60/1	187/253	26.0	16.6	79.0	31.6	7.0	23.6	27.8	40
208-230/60/3		187/253	16.3	10.4	73.0	43.8	7.0	17.4	20.0	30	
460/60/3		414/506	9.0	5.8	38.0	22.8	6.9	12.7	14.1	15	
048	208-230/60/1	187/253	31.0	19.9	109.0	43.6	4.0	23.9	28.9	45	
	208-230/60/3	187/253	21.2	13.6	83.1	49.9	4.0	17.6	21.0	30	
	460/60/3	414/506	9.5	6.1	41.0	24.6	4.1	10.2	11.7	15	
048*	208-230/60/1	187/253	31.0	19.9	109.0	43.6	7.0	26.9	31.9	50	
	208-230/60/3	187/253	21.2	13.6	83.1	49.9	7.0	20.6	24.0	35	
	460/60/3	414/506	9.5	6.1	41.0	24.6	6.9	13.0	14.5	20	
060	208-230/60/1	187/253	41.2	26.4	134.0	53.6	7.0	33.4	40.0	60	
	208-230/60/3	187/253	24.9	16.0	110.0	66.0	7.0	23.0	27.0	40	
	460/60/3	414/506	12.1	7.8	52.0	31.2	6.9	14.7	16.7	20	
070	208-230/60/1	187/253	44.2	28.3	178.0	71.2	7.0	35.3	42.4	70	
	208-230/60/3	187/253	30.0	19.2	136.0	81.6	7.0	26.2	31.0	50	
	460/60/3	414/506	13.6	8.7	66.1	39.7	6.9	15.6	17.8	25	
Dual Capacity	026	208-230/60/1	187/253	18.2	11.7	58.3	23.3	4.0	15.7	18.6	30
		265/60/1	238/292	14.2	9.1	54.0	n/a	4.1	13.2	15.5	20
		208-230/60/3	187/253	10.1	6.5	55.4	33.2	4.0	10.5	12.1	15
		460/60/3	414/506	5.4	3.5	28.0	16.8	4.1	7.6	8.4	10/15
	038	208-230/60/1	187/253	23.8	15.3	83.0	33.2	4.0	19.3	23.1	35
		265/60/1	238/292	20.3	13.0	72.0	n/a	4.1	17.1	20.4	30
		208-230/60/3	187/253	18.1	11.6	73.0	43.8	4.0	15.6	18.5	30
	038*	460/60/3	414/506	8.9	5.7	38.0	22.8	4.1	9.8	11.2	15
		208-230/60/1	187/253	23.8	15.3	83.0	33.2	7.0	22.3	26.1	40
		265/60/1	238/292	20.3	13.0	72.0	n/a	7.0	20.0	23.3	35
		208-230/60/3	187/253	18.1	11.6	73.0	43.8	7.0	18.6	21.5	30
	049	460/60/3	414/506	8.9	5.7	38.0	22.8	6.9	12.6	14.0	15
208-230/60/1		187/253	33.0	21.1	104.0	41.6	4.0	25.1	30.4	50	
208-230/60/3		187/253	21.9	14.0	83.1	49.9	4.0	18.0	21.5	35	
049*	460/60/3	414/506	10.0	6.4	41.0	24.6	4.1	10.5	12.1	15	
	208-230/60/1	187/253	33.0	21.1	104.0	41.6	7.0	28.1	33.4	50	
	208-230/60/3	187/253	21.9	14.0	83.1	49.9	7.0	21.0	24.5	35	
064	460/60/3	414/506	10.0	6.4	41.0	24.6	6.9	13.3	14.9	20	
	208-230/60/1	187/253	42.3	27.1	152.9	61.2	7.0	34.1	40.9	60	
	208-230/60/3	187/253	25.8	16.5	110.0	66.0	7.0	23.5	27.6	40	
072	460/60/3	414/506	11.3	7.2	52.0	31.2	6.9	14.1	15.9	20	
	208-230/60/1	187/253	46.3	29.7	179.2	71.7	7.0	36.7	44.1	70	
	208-230/60/3	187/253	27.4	17.6	136.0	81.6	7.0	24.6	29.0	45	
		460/60/3	414/506	13.2	8.5	66.1	39.7	6.9	15.4	17.5	25

HACR circuit breaker in USA only

*With optional 1 HP variable speed ECM motor

**With optional IntelliStart

5/21/13



CAUTION: When installing a unit with a variable speed ECM blower motor in 460/60/3 voltage, a neutral wire is required to allow proper unit operation.

Blower Performance Data

Standard PSC Motor

Model	Blower Spd	Blower Size	Motor HP	Airflow (cfm) at External Static Pressure (in. wg)																	
				0	0.05	0.10	0.15	0.20	0.25	0.30	0.35	0.40	0.45	0.50	0.60	0.70	0.80	0.90	1.00		
009	H	6 x 8	1/10	480	450	440	420	410	380	360	340	330	310	300	280	270	-	-	-	-	-
	MH			440	410	400	380	370	350	330	310	300	280	270	-	-	-	-	-	-	-
	ML*			395	370	360	340	330	310	290	280	270	250	240	-	-	-	-	-	-	-
	L			325	310	300	280	270	250	240	230	220	210	200	-	-	-	-	-	-	-
012	H	6 x 8	1/10	480	450	440	420	410	380	360	340	330	310	300	280	270	-	-	-	-	-
	MH*			440	410	400	380	370	350	330	310	300	280	270	-	-	-	-	-	-	-
	ML			395	370	360	340	330	310	290	280	270	250	240	-	-	-	-	-	-	-
	L			325	310	300	280	270	250	240	230	220	210	200	-	-	-	-	-	-	-
015	H	9 x 7	1/6	845	835	825	815	800	790	775	755	735	710	680	565	-	-	-	-	-	
	M			735	730	725	715	705	700	690	675	660	630	600	485	-	-	-	-	-	
	L			620	615	610	605	600	590	580	565	550	520	490	-	-	-	-	-	-	
018	H	9 x 7	1/6	845	835	825	815	800	790	775	755	735	710	680	565	-	-	-	-	-	
	M			735	730	725	715	705	700	690	675	660	630	600	485	-	-	-	-	-	
	L			620	615	610	605	600	590	580	565	550	520	490	-	-	-	-	-	-	
024	H	9 x 7	1/5	1085	1055	1030	1005	980	950	925	895	870	830	795	735	555	-	-	-	-	
	M			915	895	875	855	835	815	795	765	735	705	675	590	520	-	-	-	-	
	L			845	830	815	795	775	750	725	702.5	680	650	625	505	-	-	-	-	-	
030	H	9 x 7	1/3	1290	1270	1245	1220	1190	1160	1125	1090	1055	1020	985	880	760	-	-	-	-	
	M			1100	1090	1075	1060	1045	1020	995	970	940	910	875	785	625	-	-	-	-	
	L			910	905	900	895	885	875	865	850	835	810	780	710	560	-	-	-	-	
036	H	10 x 10	1/2	1665	1640	1610	1580	1550	1515	1480	1450	1415	1315	1215	1090	980	-	-	-	-	
	M			1465	1445	1425	1400	1375	1350	1325	1260	1190	1140	1090	990	890	-	-	-	-	
	L			1130	1115	1100	1090	1075	1035	995	965	930	895	860	795	730	-	-	-	-	
042	H	10 x 10	1/2	2010	1975	1940	1905	1870	1825	1780	1735	1690	1640	1590	1470	1210	-	-	-	-	
	M			1670	1650	1630	1610	1590	1560	1530	1495	1460	1425	1390	1190	1080	-	-	-	-	
	L			1220	1215	1210	1295	1200	1180	1160	1130	1100	1060	1020	930	-	-	-	-	-	
048	H	10 x 10	1/2	2010	1975	1940	1905	1870	1825	1780	1735	1690	1640	1590	1470	1210	-	-	-	-	
	M			1670	1650	1630	1610	1590	1560	1530	1495	1460	1425	1390	1190	1080	-	-	-	-	
	L			1220	1215	1210	1295	1200	1180	1160	1130	1100	1060	1020	930	-	-	-	-	-	
060	H	11 x 10	1	2430	2400	2365	2330	2290	2255	2215	2180	2140	2095	2045	1945	1835	1715	1510	1330		
	M			2265	2235	2205	2175	2145	2110	2070	2035	2000	1960	1915	1825	1730	1605	1440	1260		
	L			2075	2050	2020	1995	1965	1940	1915	1885	1850	1820	1785	1720	1610	1505	1335	1175		
070	H	11 x 10	1	2430	2400	2365	2330	2290	2255	2215	2180	2140	2095	2045	1945	1835	1715	1510	1330		
	M			2265	2235	2205	2175	2145	2110	2070	2035	2000	1960	1915	1825	1730	1605	1440	1260		
	L			2075	2050	2020	1995	1965	1940	1915	1885	1850	1820	1785	1720	1610	1505	1335	1175		

3/16/12

Optional High Static PSC Motor

Model	Blower Spd	Blower Size	Motor HP	Airflow (cfm) at External Static Pressure (in. wg)																
				0	0.05	0.10	0.15	0.20	0.25	0.30	0.35	0.40	0.45	0.50	0.60	0.70	0.80	0.90	1.00	
024	H	9 x 7	1/3	1290	1270	1245	1220	1190	1160	1125	1090	1055	1020	985	880	760	-	-	-	-
	M			1100	1090	1075	1060	1045	1020	995	970	940	910	875	785	625	-	-	-	-
	L			910	905	900	895	885	875	865	850	835	810	780	710	560	-	-	-	-
030	H	9 x 7	1/2	1365	1340	1325	1305	1280	1250	1215	1180	1140	1100	1055	960	850	-	-	-	-
	M			1040	1040	1035	1030	1020	1005	990	970	945	915	885	810	735	-	-	-	-
	L			880	880	880	880	875	870	860	840	820	800	775	730	480	-	-	-	-
036	H	10 x 10	1/2	1930	1905	1875	1840	1805	1765	1725	1680	1635	1530	1425	1270	1150	1025	-	-	-
	M			1635	1620	1600	1580	1555	1530	1505	1465	1425	1335	1240	1135	1035	775	-	-	-
	L			1230	1230	1225	1215	1200	1165	1130	1095	1060	1035	1005	935	795	675	-	-	-
042	H	10 x 10	3/4	2115	2075	2035	1980	1920	1900	1880	1840	1795	1730	1660	1390	1225	1070	-	-	-
	M			2005	1980	1950	1910	1865	1815	1765	1725	1685	1585	1485	1315	1140	1025	-	-	-
	L			1860	1835	1805	1780	1750	1715	1675	1635	1590	1540	1490	1260	1115	980	-	-	-
048	H	10 x 10	3/4	2115	2075	2035	1980	1920	1900	1880	1840	1795	1730	1660	1390	1225	1070	-	-	-
	M			2005	1980	1950	1910	1865	1815	1765	1725	1685	1585	1485	1315	1140	1025	-	-	-
	L			1860	1835	1805	1780	1750	1715	1675	1635	1590	1540	1490	1260	1115	980	-	-	-

3/16/12

Factory settings are in Bold

Air flow values are with dry coil and 1 in. MERV 4.

For wet coil performance first calculate the face velocity of the air coil (Face Velocity [fpm] = Airflow [cfm] / Face Area [sq ft]).

Then for velocities of 200 fpm reduce the static capability by 0.03 in. wg, 300 fpm by 0.08 in. wg, 400 fpm by 0.12 in. wg. and 500 fpm by 0.16 in. wg.

* Denotes setting for 265 V operation.

Setting Blower Speed - PSC

CAUTION: Disconnect all power before performing this operation.

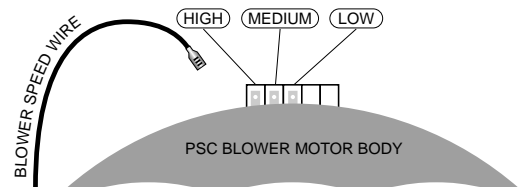

Blower Performance Data cont.

5-Speed ECM - Single Speed

Model	Motor Spd	Motor Tap	T*Stat Cnct.	Blower Size	Motor HP	Airflow (cfm) at External Static Pressure (in. wg)																
						0	0.05	0.10	0.15	0.20	0.25	0.30	0.35	0.40	0.45	0.50	0.60	0.70	0.80	0.90	1.00	
015	High	5		9 x 7	1/2	916	898	881	866	851	679	813	804	795	774	754	731	695	643	-	-	
	Med High	4	W			809	787	765	754	743	725	707	688	669	654	639	606	536	-	-	-	-
	Med	3				727	715	703	682	661	638	616	601	587	561	536	485	-	-	-	-	-
	Med Low	2	Y1			699	675	652	631	611	594	577	551	525	490	455	-	-	-	-	-	-
	Low	1	G			656	604	552	530	508	493	479	436	394	350	-	-	-	-	-	-	-
018	High	5		9 x 7	1/2	916	898	881	866	851	679	813	804	795	774	754	731	695	643	-	-	
	Med High	4	W			809	787	765	754	743	725	707	688	669	654	639	606	536	-	-	-	-
	Med	3				727	715	703	682	661	638	616	601	587	561	536	485	-	-	-	-	-
	Med Low	2	Y1			699	675	652	631	611	594	577	551	525	490	455	-	-	-	-	-	-
	Low	1	G			656	604	552	530	508	493	479	436	394	350	-	-	-	-	-	-	-
024	High	5	W	9 x 7	1/2	1015	1003	990	975	955	945	935	920	905	890	880	850	825	745	-	-	
	Med High	4	Y1			935	915	895	880	875	855	840	825	815	800	785	755	720	580	-	-	
	Med	3				865	855	845	825	810	795	780	765	750	735	720	675	610	570	-	-	
	Med Low	2	G			810	790	770	755	740	725	710	695	680	660	640	560	530	-	-	-	
	Low	1				695	645	595	575	550	520	495	455	420	400	-	-	-	-	-	-	
030	High	5		9 x 7	1/2	1407	1381	1354	1327	1300	1267	1233	1201	1168	1131	1094	1009	-	-	-	-	
	Med High	4	W			1146	1134	1122	1111	1099	1085	1071	1062	1052	1042	1031	966	-	-	-	-	
	Med	3	Y1			1023	1012	1001	985	969	959	949	937	925	913	901	-	-	-	-	-	
	Med Low	2				978	962	946	934	922	907	891	882	872	858	843	-	-	-	-	-	
	Low	1	G			795	777	759	748	737	718	698	686	673	650	626	-	-	-	-	-	
036	High	5	W	11 x 10	1/2	1530	1503	1476	1453	1429	1413	1397	1376	1355	1342	1329	1276	1231	1173	-	-	
	Med High	4	Y1			1413	1388	1363	1342	1321	1303	1285	1263	1240	1226	1212	1173	1016	946	-	-	
	Med	3				1355	1325	1294	1276	1258	1235	1212	1188	1164	1144	1123	982	909	883	-	-	
	Med Low	2				1336	1299	1261	1242	1222	1202	1181	1157	1132	1111	1090	937	874	830	-	-	
	Low	1	G			1243	1182	1121	1061	1000	964	928	856	784	744	703	647	592	-	-	-	
042	High	5		11 x 10	1	1934	1910	1886	1871	1855	1827	1799	1780	1760	1747	1734	1700	1659	1617	-	-	
	Med High	4	W			1799	1783	1767	1744	1720	1693	1666	1649	1631	1617	1603	1560	1530	1492	-	-	
	Med	3				1694	1680	1666	1642	1617	1592	1567	1552	1537	1519	1500	1453	1421	1372	-	-	
	Med Low	2	Y1			1575	1560	1540	1520	1502	1487	1471	1448	1424	1409	1393	1351	1308	1266	-	-	
	Low	1	G			1454	1406	1358	1333	1308	1285	1261	1239	1217	1198	1179	1072	1002	988	-	-	
048	High	5		11 x 10	1	1934	1910	1886	1871	1855	1827	1799	1780	1760	1747	1734	1700	1659	1617	-	-	
	Med High	4	W			1799	1783	1767	1744	1720	1693	1666	1649	1631	1617	1603	1560	1530	1492	-	-	
	Med	3	Y1			1694	1680	1666	1642	1617	1592	1567	1552	1537	1519	1500	1453	1421	1372	-	-	
	Med Low	2				1575	1560	1540	1520	1502	1487	1471	1448	1424	1409	1393	1351	1308	1266	-	-	
	Low	1	G			1454	1406	1358	1333	1308	1285	1261	1239	1217	1198	1179	1072	1002	988	-	-	
060	High	5	W	11 x 10	1	2230	2212	2193	2173	2152	2139	2125	2109	2092	2076	2059	2026	1992	1951	1892	1806	
	Med High	4	Y1			2081	2065	2048	2032	2015	1998	1980	1963	1946	1928	1910	1880	1849	1806	1767	1728	
	Med	3				1951	1931	1910	1889	1868	1850	1831	1812	1793	1774	1755	1722	1688	1654	1612	1562	
	Med Low	2				1812	1790	1767	1748	1728	1708	1688	1671	1654	1640	1626	1584	1547	1510	1472	1417	
	Low	1	G			1668	1651	1633	1612	1591	1566	1540	1525	1510	1491	1472	1433	1400	1351	1299	1208	
070	High	5	W	11 x 10	1	2472	2454	2435	2414	2393	2371	2349	2328	2306	2289	2271	2236	2189	2121	2033	1936	
	Med High	4	Y1			2271	2248	2225	2205	2184	2166	2147	2129	2110	2094	2078	2039	2011	1977	1930	1846	
	Med	3				2133	2115	2096	2072	2047	2030	2013	1996	1979	1965	1950	1909	1873	1837	1793	1748	
	Med Low	2				2008	1985	1962	1939	1915	1898	1880	1862	1843	1828	1812	1774	1742	1703	1669	1635	
	Low	1	G			1806	1784	1761	1742	1722	1696	1669	1656	1642	1625	1607	1564	1527	1490	1443	1404	

Factory settings are in Bold
Air flow values are with dry coil and standard 1 in. filter

11/20/12

About 5-Speed ECM Constant Torque Motors

The 5-speed ECM is a 'Constant Torque' ECM motor and delivers air flow similar to a PSC but operates as efficiently as a variable speed ECM motor. Because it is an ECM motor, the 5-speed ECM can ramp slowly up or down like the variable speed ECM motor. There are 5 possible speed taps available on the 5-speed ECM motor with #1 being the lowest airflow and #5 being the highest airflow. These speed selections are preset at the time of manufacture and are easily changed in the field if necessary.

If more than one tap are energized at the same time, built in logic gives precedence to the highest tap number and allows air flow to change with G, Y1, Y2 and W signals. Each of those 5 speeds has a specific 'Torque' value programmed into the motor for each speed selection. As static pressure increases,

airflow decreases resulting in less torque on the rotor. The motor responds only to changes in torque and adjusts its speed accordingly.

The 5-speed ECM motor is powered by line voltage but the motor speed is energized by 24VAC.

5-Speed ECM Benefits:

- High efficiency
- Soft start
- 5 speeds with up to 4 speeds on-line
- Built in logic allows air flow to change with G, Y1, Y2 and W signals
- Super efficient low airflow continuous blower setting (G)

Blower Performance Data cont.

5-Speed ECM - Dual Capacity

Model	Motor Speed	Motor Tap	T'stat Cnct.	Blower Size	Motor HP	Airflow (cfm) at External Static Pressure (in. wg)															
						0	0.05	0.10	0.15	0.20	0.25	0.30	0.35	0.40	0.45	0.50	0.60	0.70	0.80	0.90	1.00
026	High	5	W	9 x 7	1/2	1120	1109	1097	1082	1066	1055	1044	1028	1011	1001	991	932	839	-	-	-
	Med High	4	Y2			1020	1006	991	980	968	950	932	922	911	894	876	849	812	-	-	-
	Med	3				917	906	895	884	872	854	836	824	812	792	772	754	719	-	-	-
	Med Low	2	Y1			836	824	812	794	776	765	754	735	715	703	691	653	631	-	-	-
	Low	1	G			735	721	707	687	666	653	640	622	603	589	574	533	-	-	-	-
038	High	5	W	11 x 10	1/2	1530	1503	1476	1453	1429	1413	1397	1376	1355	1342	1329	1276	1231	1173	-	-
	Med High	4	Y2			1413	1388	1363	1342	1321	1303	1285	1263	1240	1226	1212	1173	1016	946	-	-
	Med	3	Y1			1355	1325	1294	1276	1258	1235	1212	1188	1164	1144	1123	982	909	883	-	-
	Med Low	2				1336	1299	1261	1242	1222	1202	1181	1157	1132	1111	1090	937	874	830	-	-
	Low	1	G			1243	1182	1121	1061	1000	964	928	856	784	744	703	647	592	-	-	-
049	High	5	W	11 x 10	1	1934	1910	1886	1871	1855	1827	1799	1780	1760	1747	1734	1700	1659	1617	-	-
	Med High	4				1799	1783	1767	1744	1720	1693	1666	1649	1631	1617	1603	1560	1530	1492	-	-
	Med	3	Y2			1694	1680	1666	1642	1617	1592	1567	1552	1537	1519	1500	1453	1421	1372	-	-
	Med Low	2	Y1			1575	1560	1540	1520	1502	1487	1471	1448	1424	1409	1393	1351	1308	1266	-	-
	Low	1	G			1454	1406	1358	1333	1308	1285	1261	1239	1217	1198	1179	1072	1002	988	-	-
064	High	5	W	11 x 10	1	2245	2360	2214	2315	2173	2290	2136	2275	2103	2250	2070	2032	1998	1957	1910	1825
	Med High	4	Y2			2092	2073	2054	2035	2015	1995	1975	1958	1940	1922	1904	1880	1843	1806	1767	1728
	Med	3				1951	1931	1910	1889	1868	1850	1831	1812	1793	1774	1755	1722	1688	1654	1612	1562
	Med Low	2	Y1			1812	1796	1780	1761	1741	1718	1695	1682	1668	1651	1633	1591	1555	1518	1480	1433
	Low	1	G			1682	1661	1640	1616	1591	1573	1555	1533	1510	1495	1480	1441	1400	1351	1316	1263
072	High	5	W	11 x 10	1	2472	2360	2435	2315	2393	2290	2349	2275	2306	2250	2271	2236	2189	2121	2033	1936
	Med High	4	Y2			2271	2248	2225	2205	2184	2166	2147	2129	2110	2094	2078	2039	2011	1977	1930	1846
	Med	3				2133	2115	2096	2072	2047	2030	2013	1996	1979	1965	1950	1909	1873	1837	1793	1748
	Med Low	2	Y1			2008	1985	1962	1939	1915	1898	1880	1862	1843	1828	1812	1774	1742	1703	1669	1635
	Low	1	G			1806	1784	1761	1742	1722	1696	1669	1656	1642	1625	1607	1564	1527	1490	1443	1404

Factory speed settings are in Bold

Air flow values are with dry coil and standard filter

For wet coil performance first calculate the face velocity of the air coil (Face Velocity [fpm] = Airflow [cfm] / Face Area [sq ft]).

Then for velocities of 200 fpm reduce the static capability by 0.03 in. wg, 300 fpm by 0.08 in. wg, 400 fpm by 0.12 in. wg., and 500 fpm by 0.16 in. wg.

Highest setting is for auxiliary heat (W) and lowest setting is for constant blower (G). The "Y1" and "Y2" settings must be between the "G" and "W" settings.

3/16/12

Setting Blower Speed - 5-Speed ECM

5-speed ECM blower motors have five (5) speeds of which three (3) are selectable on single speed and four (4) are selectable on dual capacity.

 **CAUTION: Disconnect all power before performing this operation.**

5-Speed ECM Motor Connections - Single Speed

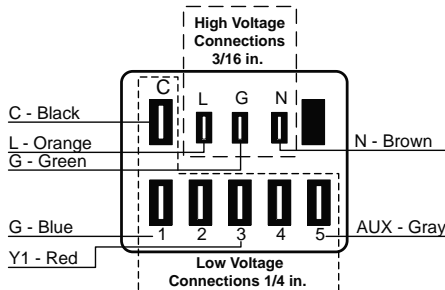

5-Speed ECM Motor Connections - Dual Capacity

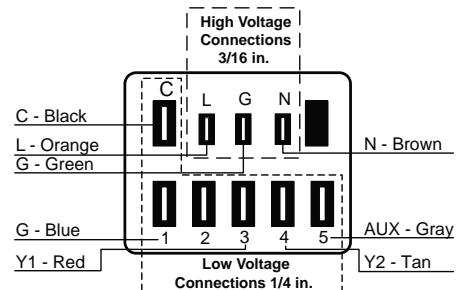

Blower Performance Data cont.

Variable Speed ECM Motor Single Speed

Model	Max ESP	Blower Size	Motor hp	Airflow DIP Switch Settings												
				1	2	3	4	5	6	7	8	9	10	11	12	
015	0.50	9 x 7	1/2	300	400 L	500	600 M	700 H								
018	0.50	9 x 7	1/2	300	400 L	500	600 M	700 H	800							
024	0.50	9 x 7	1/2		400	500 L	600 M	700 H	800 H	900	1000	1100	1200			
030	0.50	9 x 7	1/2		400	500 L	600	700 M	800 H	900 H	1000	1100	1200			
036	0.50	11 x 10	1/2	650	750	850 L	1000	1100 M	1200 H	1300 H	1400	1500				
036 w/1hp*	0.75	11 x 10	1	800	1000 L	1100 M	1300 H	1500	1600	1800						
042	0.50	11 x 10	1/2	650	800	900 L	1050	1150 M	1250 H	1350 H	1450 H	1550				
042 w/1hp*	0.75	11 x 10	1	800	900 L	1000	1200 M	1400 H	1600	1700	1850	2000	2200	2300	2400	
048	0.50	11 x 10	1/2	650	800	900 L	1050 L	1150	1250 M	1350 M	1450 H	1550 H				
048 w/1hp*	0.75	11 x 10	1	800	900	1000 L	1200	1400 M	1600 H	1700 H	1850	2000	2200	2300	2400	
060	0.75	11 x 10	1	800	950	1100 L	1300	1500 M	1750 H	1950 H	2100	2300				
070	0.75	11 x 10	1	800	950	1100 L	1300	1500 M	1750 M	1950 H	2100 H	2300				

3/16/12

Dual Capacity

Model	Max ESP	Blower Size	Motor hp	Air Flow DIP Switch Settings												
				1	2	3	4	5	6	7	8	9	10	11	12	
026	0.50	9 x 7	1/2		400	500 L	600	700 M	800 H	900 H	1000	1100	1200			
038	0.50	11 x 10	1/2	650	750 L	850	1000	1100 M	1200 H	1300 H	1400	1500				
038 w/1hp*	0.75	11 x 10	1	800 L	1000	1100 M	1300 H	1500	1600	1800						
049	0.50	11 x 10	1/2	650	800 L	900	1050	1150	1250 M	1350 M	1450 H	1550 H				
049 w/1hp*	0.75	11 x 10	1	800 L	900	1000	1200	1400 M	1600 H	1700 H	1850	2000	2200	2300	2400	
064	0.75	11 x 10	1	800	950 L	1100	1300	1500 M	1750 H	1950 H	2100	2300				
072	0.75	11 x 10	1	800	950	1100 L	1300	1500 M	1750 M	1950 H	2100 H	2300				

Factory settings are at recommended L-M-H DIP switch locations
 M-H settings MUST be located within boldface cfm range
 Lowest and Highest DIP switch settings are assumed to be L and H respectively
 cfm is controlled within 35% up to the maximum ESP
 Max ESP includes allowance for wet coil and 1 in. MERV 4

3/16/12

Blower Performance Data cont.

Setting Blower Speed - Variable Speed ECM

The ABC board's Yellow Config LED will flash the current variable speed ECM blower speed selections for low, med, and high continuously with a short pause in between. The speeds can also be confirmed with the AID Tool under the Setup/ECM Setup screen. The variable speed ECM blower motor speeds can be field adjusted with or without using an AID Tool.

Variable Speed ECM Setup without an AID Tool

The blower speeds for Low (G only), Med (Y1), and High (Y2/Aux) can be adjusted directly at the Aurora ABC board which utilizes the push button (SW1) on the ABC board. This procedure is outlined in the Variable Speed ECM Configuration Mode portion of the Aurora 'Base' Control System section.

Variable Speed ECM Setup with an AID Tool

A much easier method utilizes the AID Tool to change the airflow using the procedure below. First navigate to the Setup screen and then select ECM Setup. This screen displays the current variable speed ECM settings. It allows the technician to enter the setup screens to change the variable speed ECM settings. Change the highlighted item using the ◀ and ▶ buttons and then press the ◻ button to select the item.

Variable Speed ECM Setup with an AID Tool cont.

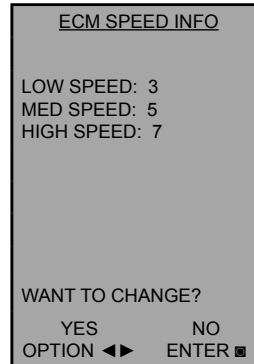

Selecting YES will enter variable speed ECM speed setup, while selecting NO will return to the previous screen.

Variable Speed ECM Speed Setup - These screens allow the technician to select the low, medium, and high blower speed for the variable speed ECM blower motor. Change the highlighted item using the ▲ and ▼ buttons. Press the ◻ button to select the speed.

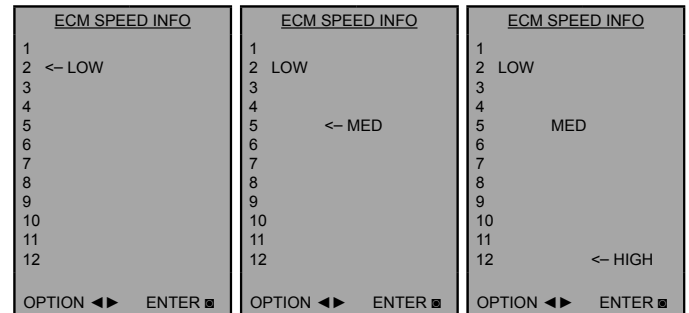

After the high speed setting is selected the AID Tool will automatically transfer back to the ECM Setup screen.

Selection Example

To achieve optimal performance, proper selection of each heat pump is essential. A building load program should be used to determine the heating and cooling load of each zone. A computer software selection program can then be used to develop an accurate and complete heat pump schedule. Software can be obtained from your local WaterFurnace representative.

While a computer software program is the easiest and most accurate method to size and select equipment, however, selection can still be accomplished manually using this manual and the following selection procedure. Sizing so that the actual sensible capacity of the equipment will satisfy the sensible capacity of the zone is the recommended method for best results.

Boiler/Tower Application

Typical boiler/tower application will result in entering water temperatures of 60-90°F with 70°F for heating and 90°F for cooling. Water to refrigerant insulation option would not be required. Flow rates are 2.5 to 3 gpm per ton with 2.5 gpm per ton often representing an economical design point.

Geothermal Application

Typical geothermal application can result in a wide entering water temperature range of 30-100°F. Typically minimum heating entering water temperatures can range from 30 to 50°F depending upon loop type and geographical location. Cooling performance should be calculated using a maximum loop temperature of 100°F in most loop applications. Water flow is typically 2.5 to 3 gpm per ton with 3 gpm per ton recommended with the more extreme loop temperatures. **PLEASE NOTE THAT WATER COIL INSULATION OPTION SHOULD BE SELECTED WHEN ENTERING WATER TEMPERATURES ARE EXPECTED TO BE BELOW 45-50°F.**

Geothermal Selection Example

Step 1: Determine the actual heating and cooling loads at the desired dry bulb and wet bulb conditions.

Step 2: Obtain the following design parameters: Entering water temperature, water flow rate in gpm, airflow in cfm, water flow pressure drop and design wet and dry bulb temperatures. Airflow, cfm, should be between 300 and 450 cfm per ton. Unit water pressure drop should be kept as close as possible to each other to make water balancing easier. Go to the appropriate tables and find the proper indicated water flow and water temperature.

Step 3: Select a unit based on total and sensible cooling conditions. Select a unit which is closest to, but no larger than, the actual cooling load.

Step 4: Enter tables at the design water flow and water temperature. Read the total and sensible cooling capacities (**NOTE:** interpolation is permissible, extrapolation is not).

Step 5: Read the heating capacity. If it exceeds the design criteria it is acceptable. It is quite normal for water source heat pumps to be selected on cooling capacity only since the heating output is usually greater than the cooling capacity.

Step 6: Determine the correction factors associated with the variable factors of dry bulb and wet bulb.
 Corrected Total Cooling = tabulated total cooling x wet bulb correction.
 Corrected Sensible Cooling = tabulated sensible cooling x wet/dry bulb correction.

Step 7: Compare the corrected capacities to the load requirements. Normally if the capacities are within 10% of the loads, the equipment is acceptable. It is better to undersize than oversize, as undersizing improves humidity control, reduces sound levels and extends the life of the equipment.

Step 8: When complete, calculate water temperature rise and assess the selection. If the units selected are not within 10% of the load calculations, then review what effect changing the gpm, water temperature and/or airflow and air temperature would have on the corrected capacities. If the desired capacity cannot be achieved, select the next larger or smaller unit and repeat the procedure. Remember, when in doubt, undersize slightly for best performance.

Example Equipment Selection - Cooling

1. Load Determination:

Assume we have determined that the appropriate cooling load at the desired dry bulb 80°F and wet bulb 65°F conditions is as follows:

Total Cooling.....	57,500 Btu/h
Sensible Cooling.....	38,400 Btu/h
Entering Air Temp.....	75°F Dry Bulb / 65°F Wet Bulb

2. Design Conditions:

Similarly, we have also obtained the following design parameters:

Entering Water Temp.....	90°F
Water Flow (Based upon 10°F rise in temp.)	15.0 gpm
Airflow Required	1,900 cfm @ 0.2 in. wg.

Selection Example cont.

3, 4 & 5. HP Selection:

After making our preliminary selection (NB*060 variable speed ECM), we enter the tables at design water flow and water temperature and read

Total Cooling, Sens. Cooling and Heat of Rej. capacities:
 Total Cooling62,600 Btu/h
 Sensible Cooling 46,000 Btu/h
 Heat of Rejection76,500 Btu/h

6 & 7. Entering Air and Airflow Corrections:

Next, we determine our correction factors. (Refer to Correction Factor Tables - Airflow and Entering Air correction tables – using 1,900 cfm. or 1,900÷2,000 nom. = 95%).
 Corrected Total Cooling = 62,600 x 0.992 x 0.967 = 60,050
 Corrected Sens Cooling = 46,000 x 0.965 x 0.881 = 39,108
 Corrected Heat of Reject = 75,000 x 0.990 x 0.972 = 72,171

$$HR = 500 \times \text{gpm} \times (T_{in} - T_{out})$$

$$\frac{HR}{500 \times \text{gpm}} = (T_{in} - T_{out}) \text{ or } \Delta T \text{ Rise}$$

$$\frac{72,171}{500 \times 15} = 9.62 \text{ } ^\circ\text{F Rise}$$

8. Water Temperature Rise Calculation & Assessment:

Note: 500 = parameters for water & 485 = parameters for antifreeze solutions to 30% weight.

When we compare the Corrected Total Cooling and Corrected Sensible Cooling figures with our load requirements stated in Step 1, we discover that our selection is within +10% of our sensible load requirement. Further more, we see that our Corrected Total Cooling figure is within 1,000 Btu/h of the actual indicated load.

Antifreeze Corrections

Catalog performance can be corrected for antifreeze use. Please use the following table and note the example given.

Antifreeze Type	Antifreeze % by wt	Cooling Capacity	Heating Capacity	Pressure Drop
EWT - degF [DegC]		90 [32.2]	30 [-1.1]	30 [-1.1]
Water	0	1.000	1.000	1.000
Ethylene Glycol	10	0.991	0.973	1.075
	20	0.979	0.943	1.163
	30	0.965	0.917	1.225
	40	0.955	0.890	1.324
	50	0.943	0.865	1.419
Propylene Glycol	10	0.981	0.958	1.130
	20	0.969	0.913	1.270
	30	0.950	0.854	1.433
	40	0.937	0.813	1.614
	50	0.922	0.770	1.816
Ethanol	10	0.991	0.927	1.242
	20	0.972	0.887	1.343
	30	0.947	0.856	1.383
	40	0.930	0.815	1.523
	50	0.911	0.779	1.639
Methanol	10	0.986	0.957	1.127
	20	0.970	0.924	1.197
	30	0.951	0.895	1.235
	40	0.936	0.863	1.323
	50	0.920	0.833	1.399

Warning: Gray area represents antifreeze concentrations greater than 35% by weight and should be avoided due to the extreme performance penalty they represent.

Antifreeze Correction Example

Antifreeze solution is Propylene Glycol 20% by weight. Determine the corrected heating and cooling performance at 30°F and 90°F respectively as well as pressure drop at 30°F for an Envision² Compact NB*024-PSC.

The corrected cooling capacity at 90°F would be: 24,300 Btu/h x 0.969 = 23,547 Btu/h

The corrected heating capacity at 30°F would be: 18,900 Btu/h x 0.913 = 17,256 Btu/h

The corrected pressure drop at 30°F and 6 gpm would be: 9.5 ft. hd x 1.270 = 12.07 ft. hd.

Reference Calculations

Heating Calculations:	Cooling Calculations:
$LWT = EWT - \frac{HE}{gpm \times 500}$	$LWT = EWT + \frac{HR}{gpm \times 500}$
$LAT = EAT + \frac{HC}{cfm \times 1.08}$	$LAT(DB) = EAT(DB) - \frac{SC}{cfm \times 1.08}$
$TH = HC + HWC$	$LC = TC - SC$
	$S/T = \frac{SC}{TC}$

Legend and Notes

ABBREVIATIONS AND DEFINITIONS:

cfm = airflow, cubic feet/minute
 EWT = entering water temperature, Fahrenheit
 gpm = water flow in gallons/minute
 WPD = water pressure drop, psi and feet of water
 EAT = entering air temperature, Fahrenheit (dry bulb/wet bulb)
 HC = air heating capacity, MBtu/h
 TC = total cooling capacity, MBtu/h
 SC = sensible cooling capacity, MBtu/h
 kW = total power unit input, kilowatts
 HR = total heat of rejection, MBtu/h

HE = total heat of extraction, MBtu/h
 HWC = hot water generator capacity, MBtu/h
 EER = Energy Efficient Ratio = BTU output/Watt input
 COP = Coefficient of Performance = Btu output/Btu input
 LWT = leaving water temperature, °F
 LAT = leaving air temperature, °F
 TH = total heating capacity, MBtu/h
 LC = latent cooling capacity, MBtu/h
 S/T = sensible to total cooling ratio

Notes (Refer to Performance Data tables)

- Performance ratings are based on 80°F DB / 67°F WB EAT for cooling and 70°F DB EAT for heating.
- Three flow rates are shown for each unit. The lowest flow rate shown is used for geothermal open loop/well water systems with a minimum of 50°F EWT. The middle flow rate shown is the minimum geothermal closed loop flow rate. The highest flow rate shown is optimum for geothermal closed loop systems and the suggested flow rate for boiler/tower applications.
- The hot water generator numbers are based on a flow rate of 0.4 gpm/ton of rated capacity with an EWT of 90°F.
- Entering water temperatures below 40°F assumes 15% antifreeze solution.
- For non-standard EAT conditions, apply the appropriate correction factors on (Refer to Correction Factor Tables).
- Interpolation between EWT, gpm, and cfm data is permissible.

Operating Limits

Operating Limits	Cooling		Heating	
	(°F)	(°C)	(°F)	(°C)
Air Limits				
Min. Ambient Air	45	7.2	45	7.2
Rated Ambient Air	80	26.7	70	21.1
Max. Ambient Air	100	37.8	85	29.4
Min. Entering Air	50	10.0	40	4.4
Rated Entering Air db/wb	80.6/66.2	27/19	68	20.0
Max. Entering Air db/wb	110/83	43/28.3	80	26.7
Water Limits				
Min. Entering Water	30	-1.1	20	-6.7
Normal Entering Water	50-110	10-43.3	30-70	-1.1
Max. Entering Water	120	48.9	90	32.2

NOTE: Minimum/maximum limits are only for start-up conditions, and are meant for bringing the space up to occupancy temperature. Units are not designed to operate at the minimum/maximum conditions on a regular basis. The operating limits are dependent upon three primary factors: 1) water temperature, 2) return air temperature, and 3) ambient temperature. When any of the factors are at the minimum or maximum levels, the other two factors must be at the normal level for proper and reliable unit operation.

Correction Factor Tables

Cooling Capacity Corrections

Entering Air WB °F	Total Clg Cap	Sensible Cooling Capacity Multipliers - Entering DB °F										Power Input	Heat of Rejection
		60	65	70	75	80	80.6	85	90	95	100		
55	0.898	0.723	0.866	1.048	1.185	*	*	*	*	*	*	0.985	0.913
60	0.912		0.632	0.880	1.078	1.244	1.260	*	*	*	*	0.994	0.927
65	0.967			0.694	0.881	1.079	1.085	1.270	*	*	*	0.997	0.972
66.2	0.983			0.655	0.842	1.040	1.060	1.232	*	*	*	0.999	0.986
67	1.000			0.616	0.806	1.000	1.023	1.193	1.330	*	*	1.000	1.000
70	1.053				0.693	0.879	0.900	1.075	1.250	1.404	*	1.003	1.044
75	1.168					0.687	0.715	0.875	1.040	1.261	1.476	1.007	1.141

NOTE: * Sensible capacity equals total capacity at conditions shown.

11/10/09

Heating Corrections

Ent Air DB °F	Htg Cap	Power	Heat of Ext
45	1.062	0.739	1.158
50	1.050	0.790	1.130
55	1.037	0.842	1.096
60	1.025	0.893	1.064
65	1.012	0.945	1.030
68	1.005	0.976	1.012
70	1.000	1.000	1.000
75	0.987	1.048	0.970
80	0.975	1.099	0.930

11/10/09

Airflow Corrections

Airflow		Cooling				Heating		
cfm Per Ton of Clg	% of Nominal	Total Cap	Sens Cap	Power	Heat of Rej	Htg Cap	Power	Heat of Ext
240	60	0.922	0.786	0.910	0.920	0.943	1.150	0.893
275	69	0.944	0.827	0.924	0.940	0.958	1.105	0.922
300	75	0.959	0.860	0.937	0.955	0.968	1.078	0.942
325	81	0.971	0.894	0.950	0.967	0.977	1.053	0.959
350	88	0.982	0.929	0.964	0.978	0.985	1.031	0.973
375	94	0.992	0.965	0.982	0.990	0.993	1.014	0.988
400	100	1.000	1.000	1.000	1.000	1.000	1.000	1.000
425	106	1.007	1.034	1.020	1.010	1.007	0.990	1.011
450	113	1.012	1.065	1.042	1.018	1.013	0.983	1.020
475	119	1.017	1.093	1.066	1.026	1.018	0.980	1.028
500	125	1.019	1.117	1.092	1.033	1.023	0.978	1.034
520	130	1.020	1.132	1.113	1.038	1.026	0.975	1.038

11/10/09

Pressure Drop

Single Speed

Model	gpm	Pressure Drop (psi)				
		30°F	50°F	70°F	90°F	110°F
009	1.5	1.9	1.8	1.7	1.6	1.5
	2.0	3.5	3.4	3.2	3.1	3.0
	3.0	6.9	6.5	6.3	6.0	5.7
	4.0	12.0	11.4	11.0	10.8	10.5
012	1.5	0.3	0.3	0.3	0.3	0.3
	2.5	1.0	1.0	1.0	1.0	1.0
	3.5	1.7	1.7	1.7	1.6	1.6
015	4.5	2.5	2.4	2.4	2.4	2.3
	2.0	0.6	0.6	0.6	0.6	0.6
	3.0	1.6	1.6	1.6	1.6	1.6
	4.0	2.6	2.6	2.6	2.6	2.5
018	5.0	3.7	3.7	3.6	3.6	3.5
	3.0	1.6	1.6	1.5	1.5	1.4
	4.0	2.9	2.9	2.8	2.8	2.7
	5.0	4.2	4.2	4.1	4.0	3.9
024	6.0	6.0	5.8	5.7	5.6	5.5
	3.0	1.1	1.1	0.9	0.8	0.6
	4.5	2.1	2.0	1.8	1.7	1.5
	6.0	4.1	4.0	3.8	3.7	3.5
030	8.0	4.5	4.4	4.1	3.9	3.7
	4.0	1.5	1.4	1.3	1.2	1.1
	6.0	3.0	2.8	2.7	2.5	2.3
	8.0	5.1	4.8	4.5	4.2	3.9
036	10.0	7.7	7.2	6.8	6.3	5.8
	5.0	1.0	1.0	0.9	0.8	0.8
	7.0	2.1	1.9	1.8	1.7	1.6
	9.0	3.6	3.3	3.0	2.8	2.6
042	12.0	6.3	5.9	5.5	5.1	4.8
	5.0	0.8	0.7	0.7	0.7	0.6
	8.0	2.1	2.1	1.9	1.8	1.7
	11.0	4.2	4.1	3.8	3.5	3.3
048	14.0	7.6	6.7	6.3	5.8	5.4
	6.0	1.1	1.0	1.0	0.9	0.8
	9.0	2.3	2.1	2.0	1.9	1.7
	12.0	3.9	3.7	3.4	3.2	3.0
060	16.0	6.7	6.3	5.9	5.5	5.1
	9.0	2.4	2.2	2.1	2.0	1.8
	12.0	3.9	3.6	3.4	3.2	2.9
	15.0	5.7	5.3	5.0	4.7	4.3
070	20.0	9.5	8.9	8.3	7.8	7.2
	12.0	3.0	2.8	2.6	2.4	2.2
	15.0	4.4	4.0	3.8	3.5	3.3
	18.0	6.0	5.5	5.1	4.8	4.4
24.0	9.7	9.1	8.5	7.9	7.3	

3/16/12

Valve	gpm	Cv	Pressure Drop (psi)
1/2 in.	1.5	9.6	0.02
	2.0	9.7	0.04
	3.0	9.9	0.09
	4.0	10.1	0.16
1/2 in.	1.5	9.6	0.02
	2.5	9.8	0.06
	3.5	10.0	0.12
	4.5	10.2	0.19
3/4 in.	2.0	9.7	0.04
	3.0	9.9	0.09
	4.0	10.1	0.16
	5.0	10.4	0.23
3/4 in.	3.0	9.9	0.09
	4.0	10.1	0.16
	5.0	10.4	0.23
	6.0	10.6	0.32
3/4 in.	3.0	9.9	0.09
	4.5	10.2	0.19
	6.0	10.6	0.32
	8.0	11.0	0.53
3/4 in.	4.0	10.1	0.16
	6.0	10.6	0.32
	8.0	11.0	0.53
	10.0	11.5	0.76
1 in.	5.0	15.9	0.10
	7.0	16.6	0.23
	9.0	17.2	0.41
	12.0	17.9	0.61
1 in.	5.0	15.9	0.10
	8.0	16.6	0.23
	11.0	17.2	0.41
	14.0	17.9	0.61
1 in.	6.0	16.1	0.14
	9.0	16.8	0.29
	12.0	17.4	0.47
	16.0	18.3	0.76
1 in.	9.0	16.8	0.29
	12.0	17.4	0.47
	15.0	18.1	0.69
	20.0	19.2	1.09
1 in.	12.0	17.4	0.47
	15.0	18.1	0.69
	18.0	18.7	0.92
	24.0	20.1	1.43

3/16/12

Dual Capacity

Model	gpm	Pressure Drop (psi)				
		30°F	50°F	70°F	90°F	110°F
026	4.0	1.4	1.3	1.2	1.1	1.0
	6.0	2.8	2.6	2.4	2.3	2.1
	8.0	4.7	4.4	4.1	3.8	3.5
	10.0	7.0	6.6	6.2	5.8	5.3
038	5.0	1.2	1.2	1.1	1.0	1.0
	7.0	2.2	2.1	1.9	1.8	1.7
	9.0	3.4	3.2	3.0	2.8	2.6
	11.0	4.9	4.6	4.3	4	3.7
049	6.0	1.2	1.2	1.1	1.0	1.0
	9.0	2.4	2.2	2.1	2.0	1.8
	12.0	3.9	3.6	3.4	3.2	2.9
	15.0	5.7	5.3	5	4.7	4.3
064	8.0	1.8	1.7	1.6	1.4	1.3
	12.0	3.8	3.5	3.3	3.0	2.8
	16.0	6.5	6.0	5.6	5.2	4.8
	20.0	9.7	9.1	8.5	8.0	7.4
072	12.0	3.2	3.0	2.8	2.6	2.4
	15.0	4.5	4.2	4.0	3.7	3.4
	18.0	6.0	5.7	5.3	4.9	4.6
	21.0	7.8	7.3	6.8	6.4	5.9

3/16/12

Valve	gpm	Cv	Pressure Drop (psi)
3/4 in.	4.0	10.1	0.16
	6.0	10.6	0.32
	8.0	11.0	0.53
	10.0	11.5	0.76
3/4 in.	5.0	10.4	0.23
	7.0	10.8	0.42
	9.0	11.2	0.64
	12.0	11.9	1.02
1 in.	6.0	16.1	0.14
	9.0	16.8	0.29
	12.0	17.4	0.47
	15.0	18.1	0.69
1 in.	9.0	16.8	0.29
	12.0	17.4	0.47
	16.0	18.3	0.76
	20.0	19.2	1.09
1 in.	12.0	17.4	0.47
	15.0	18.1	0.69
	18.0	18.7	0.92
	24.0	20.1	1.43

3/16/12

NB009 - Performance Data

Single Speed with PSC (350 cfm)

EWT °F	Flow Rate gpm	Water Pressure Drop		HEATING - EAT 70 °F					COOLING - EAT 80/67 °F					
		psi	ft/hd	HC MBtu/h	Power kW	HE MBtu/h	LAT °F	COP	TC MBtu/h	SC MBtu/h	S/T Ratio	Power kW	HR MBtu/h	EER
20	1.5	2.0	4.5	Operation not recommended					Operation not recommended					
	2.0	3.6	8.3	Operation not recommended					Operation not recommended					
	3.0	7.0	16.2	6.4	0.65	4.2	84.9	2.86	Operation not recommended					
30	1.5	1.9	4.4	Operation not recommended					Operation not recommended					
	2.0	3.5	8.1	7.4	0.68	5.1	87.5	3.19	12.0	7.8	0.65	0.38	13.3	31.6
	3.0	6.9	15.9	7.3	0.68	5.0	87.3	3.16	11.6	7.5	0.65	0.38	12.9	30.3
40	1.5	1.9	4.3	Operation not recommended					Operation not recommended					
	2.0	3.4	7.9	8.2	0.69	5.9	89.8	3.47	11.7	7.7	0.66	0.42	13.2	27.8
	3.0	6.7	15.5	8.4	0.70	6.1	90.3	3.55	11.6	7.6	0.65	0.41	13.0	28.6
50	1.5	1.8	4.2	9.0	0.71	6.5	91.7	3.69	11.4	7.6	0.67	0.48	13.0	23.7
	2.0	3.4	7.8	9.2	0.71	6.7	92.3	3.77	11.5	7.6	0.67	0.46	13.0	24.8
	3.0	6.5	15.0	9.6	0.72	7.1	93.4	3.91	11.6	7.7	0.66	0.43	13.1	27.2
60	1.5	1.8	4.0	10.1	0.73	7.6	94.6	4.04	10.9	7.4	0.68	0.55	12.7	19.9
	2.0	3.3	7.6	10.3	0.73	7.8	95.3	4.12	10.9	7.4	0.68	0.53	12.7	20.7
	3.0	6.4	14.8	10.8	0.74	8.2	96.5	4.27	11.1	7.4	0.67	0.50	12.7	22.3
70	1.5	1.7	3.9	11.2	0.75	8.6	97.6	4.37	10.4	7.1	0.69	0.61	12.4	17.0
	2.0	3.2	7.5	11.4	0.75	8.9	98.3	4.45	10.4	7.1	0.69	0.60	12.4	17.5
	3.0	6.3	14.6	11.9	0.76	9.3	99.6	4.60	10.5	7.1	0.68	0.56	12.4	18.6
80	1.5	1.7	3.8	12.5	0.77	9.9	101.1	4.77	9.9	6.9	0.70	0.69	12.2	14.3
	2.0	3.2	7.3	12.8	0.77	10.2	101.9	4.85	9.9	6.9	0.70	0.68	12.2	14.6
	3.0	6.2	14.2	13.2	0.78	10.6	103.0	4.97	9.8	6.9	0.70	0.63	12.0	15.6
90	1.5	1.6	3.7	14.0	0.79	11.3	105.0	5.19	9.4	6.7	0.71	0.78	12.1	12.1
	2.0	3.1	7.2	14.3	0.80	11.6	105.8	5.27	9.4	6.7	0.71	0.77	12.1	12.3
	3.0	6.0	13.9	14.5	0.80	11.8	106.4	5.31	9.2	6.7	0.73	0.70	11.6	13.2
100	1.5	1.6	3.6	Operation not recommended					Operation not recommended					
	2.0	3.0	7.0	Operation not recommended					9.0	6.5	0.72	0.87	12.0	10.3
	3.0	5.9	13.6	Operation not recommended					8.6	6.5	0.75	0.80	11.4	10.8
110	1.5	1.5	3.5	Operation not recommended					Operation not recommended					
	2.0	3.0	6.9	Operation not recommended					8.6	6.2	0.73	0.99	11.9	8.7
	3.0	5.7	13.2	Operation not recommended					8.0	6.3	0.78	0.90	11.1	8.9
120	1.5	1.5	3.4	Operation not recommended					Operation not recommended					
	2.0	2.9	6.8	Operation not recommended					8.2	6.0	0.74	1.12	12.0	7.3
	3.0	5.6	12.9	Operation not recommended					7.5	6.0	0.80	1.02	10.9	7.3

3/16/12

NB012 - Performance Data

Single Speed with PSC (400 cfm)

EWT °F	Flow Rate gpm	Water Pressure Drop		HEATING - EAT 70 °F					COOLING - EAT 80/67 °F					
		psi	ft/hd	HC MBtu/h	Power kW	HE MBtu/h	LAT °F	COP	TC MBtu/h	SC MBtu/h	S/T Ratio	Power kW	HR MBtu/h	EER
20	1.5	0.3	0.7	Operation not recommended					Operation not recommended					
	2.5	1.0	2.3	Operation not recommended					Operation not recommended					
	3.5	1.7	3.9	7.5	0.78	4.8	85.3	2.80	Operation not recommended					
30	1.5	0.3	0.7	Operation not recommended					Operation not recommended					
	2.5	1.0	2.3	9.0	0.80	6.3	88.8	3.29	16.3	10.3	0.63	0.43	17.8	37.7
	3.5	1.7	3.9	9.1	0.81	6.3	89.1	3.29	16.5	10.3	0.62	0.41	18.0	40.2
40	1.5	0.3	0.7	Operation not recommended					Operation not recommended					
	2.5	1.0	2.3	10.0	0.82	7.2	91.1	3.57	15.8	10.1	0.64	0.49	17.4	31.9
	3.5	1.7	3.9	10.3	0.83	7.4	91.7	3.64	16.0	10.1	0.63	0.46	17.6	34.9
50	1.5	0.3	0.7	10.6	0.83	7.8	92.5	3.75	15.0	10.0	0.66	0.61	17.1	24.6
	2.5	1.0	2.3	11.0	0.83	8.2	93.5	3.86	15.2	9.9	0.65	0.56	17.1	27.3
	3.5	1.7	3.8	11.4	0.84	8.5	94.4	3.97	15.5	9.9	0.64	0.51	17.2	30.6
60	1.5	0.3	0.7	11.8	0.85	8.9	95.2	4.08	14.5	9.7	0.67	0.69	16.9	21.1
	2.5	1.0	2.3	12.2	0.85	9.3	96.3	4.21	14.7	9.7	0.66	0.64	16.9	23.1
	3.5	1.7	3.8	12.7	0.86	9.8	97.4	4.33	14.9	9.7	0.65	0.59	16.9	25.3
70	1.5	0.3	0.7	12.9	0.86	10.0	98.0	4.40	14.1	9.4	0.67	0.77	16.7	18.3
	2.5	1.0	2.3	13.5	0.87	10.5	99.2	4.54	14.2	9.5	0.67	0.72	16.7	19.8
	3.5	1.7	3.8	14.0	0.88	11.0	100.4	4.67	14.4	9.6	0.67	0.67	16.7	21.4
80	1.5	0.3	0.7	14.3	0.88	11.3	101.2	4.76	13.6	9.2	0.68	0.87	16.6	15.7
	2.5	1.0	2.2	14.9	0.89	11.9	102.6	4.92	13.8	9.3	0.68	0.82	16.6	16.8
	3.5	1.6	3.8	15.3	0.90	12.2	103.4	5.00	13.9	9.4	0.68	0.76	16.5	18.2
90	1.5	0.3	0.7	15.8	0.90	12.8	104.7	5.15	13.2	9.0	0.68	0.97	16.5	13.6
	2.5	1.0	2.2	16.5	0.91	13.4	106.3	5.34	13.3	9.2	0.69	0.93	16.5	14.2
	3.5	1.6	3.8	16.6	0.92	13.5	106.4	5.32	13.4	9.2	0.69	0.85	16.3	15.7
100	1.5	0.3	0.7	Operation not recommended					Operation not recommended					
	2.5	1.0	2.2	Operation not recommended					12.9	9.0	0.70	1.06	16.5	12.1
	3.5	1.6	3.7	Operation not recommended					13.0	9.1	0.70	0.95	16.2	13.7
110	1.5	0.3	0.7	Operation not recommended					Operation not recommended					
	2.5	1.0	2.2	Operation not recommended					12.4	8.8	0.71	1.21	16.5	10.3
	3.5	1.6	3.6	Operation not recommended					12.6	8.9	0.71	1.05	16.2	12.0
120	1.5	0.3	0.7	Operation not recommended					Operation not recommended					
	2.5	1.0	2.2	Operation not recommended					12.0	8.6	0.72	1.37	16.7	8.8
	3.5	1.5	3.5	Operation not recommended					12.1	8.7	0.72	1.16	16.0	10.5

3/16/12

NB015 - Performance Data

Single Speed with PSC (500 cfm)

EWT °F	Flow Rate gpm	Water Pressure Drop		HEATING - EAT 70 °F					COOLING - EAT 80/67 °F					
		psi	ft/hd	HC MBtu/h	Power kW	HE MBtu/h	LAT °F	COP	TC MBtu/h	SC MBtu/h	S/T Ratio	Power kW	HR MBtu/h	EER
20	2.0	0.6	1.4	Operation not recommended					Operation not recommended					
	3.0	1.6	3.7	Operation not recommended					Operation not recommended					
	4.0	2.7	6.1	10.5	0.95	7.2	87.4	3.22	Operation not recommended					
30	2.0	0.6	1.4	Operation not recommended					Operation not recommended					
	3.0	1.6	3.7	11.3	0.99	7.9	88.8	3.32	16.2	10.5	0.65	0.52	18.0	31.1
	4.0	2.6	6.1	11.4	0.99	8.0	89.1	3.37	15.3	10.0	0.65	0.52	17.1	29.7
40	2.0	0.6	1.4	Operation not recommended					Operation not recommended					
	3.0	1.6	3.7	12.4	1.01	9.0	91.0	3.59	16.7	10.9	0.66	0.59	18.7	28.2
	4.0	2.6	6.0	12.7	1.01	9.3	91.6	3.68	16.4	10.7	0.66	0.57	18.3	28.7
50	2.0	0.6	1.4	13.3	1.04	9.7	92.6	3.76	16.9	11.3	0.67	0.70	19.3	24.2
	3.0	1.6	3.7	13.7	1.04	10.1	93.3	3.87	17.1	11.4	0.66	0.66	19.4	25.9
	4.0	2.6	6.0	14.1	1.04	10.5	94.1	3.98	17.4	11.5	0.66	0.62	19.5	27.8
60	2.0	0.6	1.4	14.7	1.05	11.1	95.2	4.09	16.1	10.9	0.68	0.79	18.8	20.3
	3.0	1.6	3.7	15.2	1.06	11.5	96.1	4.20	16.3	11.0	0.67	0.75	18.9	21.6
	4.0	2.6	6.0	15.6	1.06	12.0	96.9	4.31	16.5	11.1	0.67	0.72	19.0	23.1
70	2.0	0.6	1.4	16.1	1.07	12.4	97.8	4.40	15.2	10.5	0.69	0.89	18.3	17.2
	3.0	1.6	3.7	16.6	1.08	13.0	98.8	4.51	15.4	10.6	0.69	0.85	18.3	18.2
	4.0	2.6	6.0	17.2	1.09	13.5	99.8	4.62	15.7	10.6	0.68	0.81	18.4	19.4
80	2.0	0.6	1.4	17.7	1.09	14.0	100.8	4.76	14.5	10.2	0.70	1.00	17.9	14.4
	3.0	1.6	3.7	18.4	1.11	14.6	102.0	4.88	14.7	10.2	0.70	0.96	17.9	15.3
	4.0	2.6	5.9	18.8	1.11	15.0	102.8	4.96	14.9	10.4	0.70	0.91	18.0	16.4
90	2.0	0.6	1.4	19.5	1.11	15.7	104.2	5.15	13.7	9.9	0.72	1.13	17.6	12.2
	3.0	1.6	3.6	20.3	1.13	16.4	105.6	5.26	13.9	9.8	0.71	1.09	17.6	12.8
	4.0	2.6	5.9	20.4	1.13	16.5	105.7	5.28	14.2	10.1	0.71	1.02	17.6	13.9
100	2.0	0.6	1.4	Operation not recommended					Operation not recommended					
	3.0	1.6	3.6	Operation not recommended					13.2	9.5	0.72	1.23	17.4	10.7
	4.0	2.5	5.9	Operation not recommended					13.3	9.8	0.74	1.13	17.1	11.7
110	2.0	0.6	1.4	Operation not recommended					Operation not recommended					
	3.0	1.6	3.6	Operation not recommended					12.5	9.2	0.73	1.39	17.3	9.0
	4.0	2.5	5.9	Operation not recommended					12.4	9.5	0.76	1.25	16.7	9.9
120	2.0	0.6	1.4	Operation not recommended					Operation not recommended					
	3.0	1.6	3.6	Operation not recommended					11.9	8.8	0.74	1.58	17.3	7.6
	4.0	2.5	5.8	Operation not recommended					11.2	9.2	0.82	1.38	15.9	8.1

3/16/12

NB018 - Performance Data

Single Speed with PSC (600 cfm)

EWT °F	Flow Rate gpm	Water Pressure Drop		HEATING - EAT 70 °F					COOLING - EAT 80/67 °F					
		psi	ft/hd	HC MBtu/h	Power kW	HE MBtu/h	LAT °F	COP	HWC MBtu/h	TC MBtu/h	SC MBtu/h	S/T Ratio	Power kW	HR MBtu/h
20	3.0	1.6	3.8	Operation not recommended					Operation not recommended					
	4.0	2.9	6.8	Operation not recommended					Operation not recommended					
	5.0	4.3	9.9	12.7	1.18	8.7	87.6	3.16	1.4	Operation not recommended				
30	3.0	1.6	3.7	Operation not recommended					Operation not recommended					
	4.0	2.9	6.7	14.4	1.25	10.1	90.2	3.36	1.5	19.5	12.9	0.66	0.76	22.1
	5.0	4.2	9.7	14.6	1.26	10.3	90.5	3.40	1.5	18.8	12.4	0.66	0.74	21.4
40	3.0	1.6	3.6	Operation not recommended					Operation not recommended					
	4.0	2.9	6.6	15.9	1.31	11.4	92.5	3.55	1.6	19.9	13.0	0.65	0.81	22.7
	5.0	4.2	9.6	16.3	1.32	11.8	93.1	3.61	1.6	19.8	12.7	0.64	0.75	22.3
50	3.0	1.6	3.6	17.1	1.36	12.4	94.3	3.69	1.7	20.1	13.2	0.65	0.95	23.3
	4.0	2.9	6.6	17.5	1.37	12.8	95.0	3.75	1.7	20.4	13.1	0.64	0.86	23.3
	5.0	4.2	9.6	17.9	1.38	13.2	95.7	3.81	1.8	20.7	13.1	0.63	0.77	23.3
60	3.0	1.5	3.5	19.0	1.42	14.2	97.4	3.94	1.9	19.2	12.6	0.66	1.00	22.6
	4.0	2.8	6.5	19.4	1.43	14.5	98.0	3.98	1.9	19.4	12.6	0.65	0.94	22.6
	5.0	4.1	9.5	19.8	1.45	14.9	98.6	4.02	2.0	19.6	12.6	0.64	0.88	22.6
70	3.0	1.5	3.5	21.0	1.48	16.0	100.4	4.17	2.1	18.3	12.1	0.66	1.05	21.9
	4.0	2.8	6.5	21.4	1.50	16.3	101.0	4.18	2.1	18.4	12.1	0.66	1.02	21.9
	5.0	4.1	9.5	21.7	1.52	16.6	101.6	4.20	2.2	18.5	12.1	0.66	0.99	21.9
80	3.0	1.5	3.4	23.3	1.54	18.1	104.0	4.44	2.4	17.5	11.6	0.66	1.11	21.3
	4.0	2.8	6.4	23.7	1.57	18.3	104.5	4.43	2.4	17.5	11.6	0.67	1.12	21.3
	5.0	4.1	9.4	24.0	1.58	18.6	105.1	4.45	2.5	17.7	11.8	0.67	1.12	21.5
90	3.0	1.5	3.4	25.9	1.61	20.4	108.0	4.72	2.8	16.7	11.1	0.66	1.17	20.7
	4.0	2.8	6.4	26.1	1.64	20.5	108.3	4.68	2.8	16.6	11.2	0.67	1.22	20.8
	5.0	4.0	9.2	26.3	1.65	20.7	108.6	4.67	2.8	16.8	11.4	0.68	1.24	21.1
100	3.0	1.4	3.3	Operation not recommended					Operation not recommended					
	4.0	2.7	6.3	Operation not recommended					15.8	10.7	0.68	1.34	20.4	
	5.0	4.0	9.1	Operation not recommended					15.8	11.0	0.70	1.37	20.4	
110	3.0	1.4	3.2	Operation not recommended					Operation not recommended					
	4.0	2.7	6.2	Operation not recommended					15.0	10.3	0.69	1.46	20.0	
	5.0	3.9	9.0	Operation not recommended					14.7	10.7	0.73	1.50	19.8	
120	3.0	1.4	3.2	Operation not recommended					Operation not recommended					
	4.0	2.7	6.2	Operation not recommended					14.3	9.9	0.70	1.60	19.7	
	5.0	3.9	8.9	Operation not recommended					13.7	10.2	0.75	1.66	19.4	

3/16/12

NB024 - Performance Data

Single Speed with PSC (800 cfm)

EWT °F	Flow gpm	Water		HEATING - EAT 70 °F						COOLING - EAT 80/67 °F												
		Pressure Drop		HC MBtu/h	Power kW	HE MBtu/h	LAT °F	COP	HWC MBtu/h	TC MBtu/h	SC MBtu/h	S/T Ratio	Power kW	HR MBtu/h	EER	HWC MBtu/h						
		psi	ft/hd																			
20	3.0	1.2	2.8	Operation not recommended																		
	4.5	2.1	4.9	Operation not recommended																		
	6.0	4.2	9.7	15.4	1.50	10.3	85.8	3.01	1.6	Operation not recommended												
30	3.0	1.1	2.6	Operation not recommended																		
	4.5	2.1	4.9	19.1	1.57	13.8	90.1	3.58	1.7	26.5	17.0	0.64	0.96	29.8	27.7	---						
	6.0	4.1	9.5	18.9	1.60	13.4	89.9	3.46	1.7	26.9	17.3	0.64	0.90	30.0	29.9	---						
40	3.0	1.1	2.5	Operation not recommended																		
	4.5	2.0	4.6	21.3	1.61	15.8	92.7	3.88	1.9	27.6	18.4	0.67	1.05	31.2	26.2	---						
	6.0	4.1	9.5	21.7	1.64	16.1	93.1	3.89	1.9	27.7	18.5	0.67	1.05	31.3	26.4	---						
50	3.0	1.1	2.5	23.0	1.65	17.4	94.6	4.09	2.1	28.8	19.9	0.69	1.10	32.6	26.2	1.3						
	4.5	2.0	4.6	23.8	1.66	18.1	95.5	4.19	2.1	28.7	19.8	0.69	1.15	32.6	24.9	1.2						
	6.0	4.0	9.3	24.5	1.67	18.8	96.4	4.30	2.2	28.5	19.6	0.69	1.20	32.6	23.8	1.2						
60	3.0	1.0	2.2	25.9	1.70	20.1	97.9	4.47	2.3	27.8	19.4	0.70	1.30	32.2	21.3	1.5						
	4.5	1.9	4.4	26.7	1.71	20.8	98.8	4.57	2.4	27.8	19.4	0.70	1.30	32.2	21.4	1.4						
	6.0	3.9	9.0	27.5	1.73	21.6	99.8	4.66	2.4	27.8	19.3	0.69	1.30	32.2	21.4	1.4						
70	3.0	0.9	2.1	28.7	1.74	22.8	101.2	4.83	2.6	26.7	18.9	0.71	1.50	31.8	17.8	1.8						
	4.5	1.8	4.2	29.6	1.76	23.5	102.2	4.92	2.6	26.9	19.0	0.70	1.45	31.8	18.6	1.8						
	6.0	3.8	8.7	30.4	1.78	24.3	103.2	5.01	2.7	27.1	19.0	0.70	1.40	31.9	19.4	1.7						
80	3.0	0.8	1.9	31.8	1.81	25.6	104.8	5.16	2.9	24.9	18.5	0.74	1.68	30.6	14.8	2.3						
	4.5	1.7	3.9	32.5	1.83	26.3	105.6	5.21	2.9	25.4	18.6	0.73	1.60	30.8	15.8	2.2						
	6.0	3.7	8.5	33.2	1.85	26.9	106.4	5.26	3.0	25.7	18.7	0.73	1.55	31.0	16.6	2.1						
90	3.0	0.8	1.7	34.9	1.87	28.5	108.4	5.47	3.3	23.1	18.1	0.78	1.84	29.4	12.5	2.8						
	4.5	1.7	3.9	35.5	1.90	29.0	109.0	5.48	3.4	23.8	18.2	0.76	1.76	29.8	13.6	2.7						
	6.0	3.7	8.5	36.0	1.92	29.4	109.7	5.50	3.5	24.3	18.4	0.76	1.70	30.1	14.3	2.5						
100	3.0	0.7	1.6	Operation not recommended																		
	4.5	1.6	3.7	Operation not recommended																		
	6.0	3.6	8.3	Operation not recommended						22.4	17.6	0.79	2.01	29.3	11.1	3.4						
110	3.0	0.6	1.4	Operation not recommended																		
	4.5	1.5	3.5	Operation not recommended																		
	6.0	3.5	8.1	Operation not recommended						22.8	17.8	0.78	1.95	29.4	11.7	3.2						
120	3.0	0.6	1.3	Operation not recommended																		
	4.5	1.5	3.5	Operation not recommended																		
	6.0	3.5	8.1	Operation not recommended						20.8	16.8	0.81	2.26	28.5	9.2	4.1						
								Operation not recommended								21.2	17.1	0.81	2.20	28.7	9.6	3.9
								Operation not recommended								Operation not recommended						
								Operation not recommended								18.9	16.3	0.86	2.58	27.7	7.3	4.9
								Operation not recommended								19.3	16.5	0.85	2.50	27.8	7.7	4.6

3/16/12

NB030 - Performance Data

Single Speed with PSC (900 cfm)

EWT °F	Flow gpm	Water		HEATING - EAT 70 °F						COOLING - EAT 80/67 °F												
		Pressure Drop		HC MBtu/h	Power kW	HE MBtu/h	LAT °F	COP	HWC MBtu/h	TC MBtu/h	SC MBtu/h	S/T Ratio	Power kW	HR MBtu/h	EER	HWC MBtu/h						
		psi	ft/hd																			
20	4.0	1.4	3.5	Operation not recommended																		
	6.0	2.8	7.2	Operation not recommended																		
	8.0	4.6	12.1	17.6	1.67	11.9	88.1	3.09	2.0	Operation not recommended												
30	4.0	1.4	3.4	Operation not recommended																		
	6.0	2.7	7.0	20.2	1.66	14.6	90.8	3.57	2.2	26.4	18.9	0.71	1.06	30.0	24.9	---						
	8.0	4.4	11.8	20.7	1.68	14.9	91.2	3.61	2.2	26.9	18.8	0.70	1.03	30.4	26.1	---						
40	4.0	1.3	3.3	Operation not recommended																		
	6.0	2.6	6.8	23.7	1.70	17.9	94.4	4.07	2.4	28.7	20.4	0.71	1.14	32.6	25.1	---						
	8.0	4.3	11.4	24.2	1.72	18.3	94.9	4.12	2.5	29.1	20.3	0.70	1.11	32.9	26.1	---						
50	4.0	1.3	3.2	25.9	1.74	20.0	96.6	4.36	2.6	30.7	21.8	0.71	1.29	35.1	23.8	1.5						
	6.0	2.5	6.6	26.8	1.75	20.8	97.6	4.49	2.7	30.8	21.9	0.71	1.25	35.0	24.7	1.4						
	8.0	4.2	11.1	27.4	1.76	21.3	98.1	4.55	2.8	31.2	21.9	0.70	1.22	35.3	25.5	1.4						
60	4.0	1.2	3.1	29.1	1.80	23.0	99.9	4.75	3.0	30.0	21.4	0.72	1.40	34.7	21.4	1.8						
	6.0	2.4	6.4	30.1	1.81	23.9	101.0	4.89	3.0	30.0	21.5	0.71	1.35	34.7	22.2	1.7						
	8.0	3.9	10.7	30.7	1.82	24.5	101.6	4.93	3.1	30.4	21.5	0.71	1.32	34.9	22.9	1.6						
70	4.0	1.2	3.0	32.4	1.87	26.0	103.3	5.08	3.3	30.1	21.7	0.72	1.54	35.4	19.5	2.2						
	6.0	2.4	6.2	33.5	1.88	27.1	104.5	5.22	3.4	30.2	21.7	0.72	1.49	35.3	20.3	2.1						
	8.0	3.9	10.4	34.1	1.90	27.6	105.1	5.24	3.5	30.6	21.8	0.71	1.46	35.5	20.9	2.0						
80	4.0	1.2	2.9	35.1	1.93	28.5	106.1	5.32	3.7	28.9	21.4	0.74	1.70	34.7	17.0	2.8						
	6.0	2.3	5.9	36.4	1.95	29.7	107.4	5.46	3.8	29.0	21.4	0.74	1.64	34.6	17.7	2.7						
	8.0	3.8	10.0	36.9	1.98	30.2	108.0	5.48	3.9	29.3	21.5	0.73	1.61	34.8	18.2	2.5						
90	4.0	1.1	2.8	37.9	2.01	31.0	108.9	5.51	4.2	26.7	20.2	0.76	1.87	33.1	14.3	3.5						
	6.0	2.2	5.7	39.3	2.04	32.3	110.4	5.64	4.3	26.9	20.2	0.75	1.80	33.0	14.9	3.3						
	8.0	3.6	9.6	39.9	2.06	32.8	111.0	5.66	4.4	27.1	20.3	0.75	1.77	33.2	15.3	3.2						
100	4.0	1.1	2.7	Operation not recommended																		
	6.0	2.1	5.5	Operation not recommended																		
	8.0	3.5	9.3	Operation not recommended						25.6	20.2	0.79	2.01	32.5	12.8	4.1						
110	4.0	1.0	2.6	Operation not recommended																		
	6.0	2.0	5.3	Operation not recommended																		
	8.0	3.4	8.9	Operation not recommended						25.9	20.3	0.78	1.97	32.6	13.1	3.9						
120	4.0	1.0	2.5	Operation not recommended																		
	6.0	2.0	5.1	Operation not recommended																		
	8.0	3.2	8.6	Operation not recommended						21.7	18.9	0.87	2.22	29.3	9.8	5.0						
								Operation not recommended								22.0	19.0	0.87	2.17	29.4	10.1	4.7
								Operation not recommended								Operation not recommended						
								Operation not recommended								21.0	18.3	0.87	2.47	29.5	8.5	6.0
								Operation not recommended								21.3	18.3	0.86	2.42	29.5	8.8	5.7

3/16/12

NB036 - Performance Data

Single Speed with PSC (1250 cfm)

EWT °F	Flow gpm	Water		HEATING - EAT 70°F						COOLING - EAT 80/67 °F						
		Pressure Drop		HC MBtu/h	Power kW	HE MBtu/h	LAT °F	COP	HWC MBtu/h	TC MBtu/h	SC MBtu/h	S/T Ratio	Power kW	HR MBtu/h	EER	HWC MBtu/h
		psi	ft/hd													
20	5.0	1.0	2.4	Operation not recommended												
	7.0	2.1	4.9	Operation not recommended												
	9.0	3.6	8.2	21.8	1.99	15.0	86.1	3.21	2.4	Operation not recommended						
30	5.0	1.0	2.3	Operation not recommended												
	7.0	2.1	4.7	24.5	1.99	17.7	88.1	3.60	2.6	30.6	22.0	0.72	1.26	33.1	24.4	---
	9.0	3.5	8.0	25.0	2.01	18.1	88.5	3.64	2.7	31.1	21.4	0.69	1.22	33.5	25.6	---
40	5.0	1.0	2.3	Operation not recommended												
	7.0	2.0	4.6	28.4	2.04	21.5	91.1	4.09	3.0	33.6	23.9	0.71	1.36	36.0	24.8	---
	9.0	3.4	7.8	29.0	2.06	22.0	91.5	4.14	3.0	34.1	23.9	0.70	1.32	36.5	25.8	---
50	5.0	1.0	2.2	30.9	2.07	23.8	92.9	4.37	3.2	36.3	25.9	0.71	1.53	38.7	23.7	1.7
	7.0	1.9	4.5	32.0	2.08	24.9	93.7	4.51	3.3	36.4	26.0	0.72	1.48	38.8	24.6	1.6
	9.0	3.3	7.5	32.6	2.10	25.5	94.2	4.56	3.4	36.8	26.0	0.71	1.45	39.2	25.5	1.6
60	5.0	0.9	2.1	34.7	2.11	27.5	95.7	4.81	3.6	36.0	26.5	0.74	1.65	38.5	21.8	2.1
	7.0	1.9	4.3	35.9	2.12	28.6	96.6	4.95	3.7	36.1	26.6	0.74	1.60	38.6	22.6	2.0
	9.0	3.1	7.3	36.6	2.15	29.2	97.1	4.99	3.8	36.5	26.6	0.73	1.56	39.0	23.4	1.9
70	5.0	0.9	2.1	38.6	2.16	31.3	98.6	5.24	4.1	36.5	27.5	0.75	1.81	39.1	20.1	2.6
	7.0	1.8	4.2	40.0	2.18	32.6	99.6	5.38	4.2	36.6	27.5	0.75	1.75	39.2	20.9	2.5
	9.0	3.0	7.0	40.7	2.20	33.2	100.1	5.41	4.3	37.0	27.6	0.75	1.72	39.6	21.6	2.4
80	5.0	0.9	2.0	41.8	2.20	34.3	101.0	5.57	4.6	35.6	27.4	0.77	1.99	38.3	17.9	3.3
	7.0	1.7	4.0	43.4	2.23	35.8	102.1	5.71	4.7	35.8	27.4	0.76	1.91	38.4	18.7	3.1
	9.0	2.9	6.8	44.1	2.25	36.4	102.6	5.73	4.8	36.2	27.5	0.76	1.88	38.8	19.2	3.0
90	5.0	0.8	1.9	45.3	2.25	37.6	103.5	5.89	5.1	33.4	26.6	0.80	2.17	36.1	15.4	4.1
	7.0	1.7	3.9	47.0	2.28	39.2	104.8	6.03	5.3	33.6	26.6	0.79	2.09	36.3	16.1	3.9
	9.0	2.8	6.6	47.7	2.31	39.8	105.3	6.05	5.4	33.9	26.7	0.79	2.05	36.6	16.5	3.7
100	5.0	0.8	1.8	Operation not recommended												
	7.0	1.6	3.8	Operation not recommended												
	9.0	2.7	6.3	Operation not recommended												
110	5.0	0.8	1.8	Operation not recommended												
	7.0	1.6	3.6	Operation not recommended												
	9.0	2.6	6.1	Operation not recommended												
120	5.0	0.7	1.7	Operation not recommended												
	7.0	1.5	3.5	Operation not recommended												
	9.0	2.5	5.8	Operation not recommended												

3/16/12

NB042 - Performance Data

Single Speed with PSC (1350 cfm)

EWT °F	Flow gpm	Water		HEATING - EAT 70°F						COOLING - EAT 80/67 °F						
		Pressure Drop		HC MBtu/h	Power kW	HE MBtu/h	LAT °F	COP	HWC MBtu/h	TC MBtu/h	SC MBtu/h	S/T Ratio	Power kW	HR MBtu/h	EER	HWC MBtu/h
		psi	ft/hd													
20	5.0	0.8	1.9	Operation not recommended												
	8.0	2.3	5.3	Operation not recommended												
	11.0	4.4	10.3	25.4	2.41	17.1	87.4	3.09	3.7	Operation not recommended						
30	5.0	0.8	1.8	Operation not recommended												
	8.0	2.2	5.1	29.3	2.45	21.0	90.1	3.51	3.9	41.0	28.4	0.69	1.73	43.4	23.8	---
	11.0	4.3	10.0	29.7	2.45	21.4	90.4	3.56	4.0	41.4	27.8	0.67	1.69	43.7	24.6	---
40	5.0	0.8	1.8	Operation not recommended												
	8.0	2.1	4.9	33.3	2.52	24.7	92.9	3.88	4.3	42.7	29.7	0.70	1.81	45.1	23.5	---
	11.0	4.2	9.7	33.9	2.52	25.3	93.3	3.94	4.4	43.1	29.7	0.69	1.77	45.5	24.4	---
50	5.0	0.7	1.7	35.8	2.52	27.2	94.6	4.16	4.7	43.3	30.7	0.71	2.01	45.7	21.6	2.6
	8.0	2.1	4.8	37.3	2.57	28.5	95.6	4.26	4.8	43.8	31.0	0.71	1.93	46.2	22.7	2.5
	11.0	4.1	9.4	38.0	2.58	29.3	96.1	4.33	5.0	44.2	31.0	0.70	1.88	46.6	23.5	2.4
60	5.0	0.7	1.7	39.3	2.57	30.5	97.0	4.48	5.3	43.1	31.4	0.73	2.17	45.6	19.8	3.2
	8.0	2.0	4.6	41.1	2.63	32.1	98.2	4.58	5.4	43.6	31.7	0.73	2.08	46.1	20.9	3.0
	11.0	3.9	9.1	42.0	2.65	33.0	98.8	4.66	5.6	44.1	31.7	0.72	2.03	46.5	21.7	2.9
70	5.0	0.7	1.6	42.7	2.63	33.7	99.3	4.76	6.0	43.1	32.4	0.75	2.37	45.7	18.2	4.0
	8.0	1.9	4.5	44.8	2.70	35.5	100.7	4.86	6.1	43.8	32.8	0.75	2.26	46.4	19.4	3.8
	11.0	3.8	8.8	45.9	2.73	36.6	101.5	4.94	6.3	44.3	32.8	0.74	2.21	46.8	20.1	3.6
80	5.0	0.7	1.6	45.9	2.65	36.9	101.5	5.09	6.7	41.4	31.7	0.77	2.59	44.0	15.9	5.1
	8.0	1.9	4.3	48.4	2.73	39.0	103.2	5.18	6.9	42.1	32.0	0.76	2.47	44.7	17.0	4.8
	11.0	3.7	8.5	49.8	2.77	40.3	104.1	5.28	7.1	42.6	32.0	0.75	2.41	45.1	17.7	4.6
90	5.0	0.7	1.5	49.1	2.68	40.0	103.7	5.37	7.5	39.0	30.8	0.79	2.86	41.7	13.7	6.4
	8.0	1.8	4.2	51.8	2.78	42.4	105.6	5.47	7.8	39.8	31.1	0.78	2.72	42.5	14.7	6.1
	11.0	3.5	8.2	53.5	2.82	43.9	106.7	5.57	8.0	40.2	31.1	0.77	2.64	42.9	15.2	5.8
100	5.0	0.6	1.5	Operation not recommended												
	8.0	1.7	4.0	Operation not recommended												
	11.0	3.4	7.9	Operation not recommended												
110	5.0	0.6	1.4	Operation not recommended												
	8.0	1.7	3.9	Operation not recommended												
	11.0	3.3	7.6	Operation not recommended												
120	5.0	0.6	1.3	Operation not recommended												
	8.0	1.6	3.7	Operation not recommended												
	11.0	3.2	7.3	Operation not recommended												

3/16/12

NB048 - Performance Data

Single Speed with PSC (1500 cfm)

EWT °F	Flow gpm	Water		HEATING - EAT 70°F						COOLING - EAT 80/67 °F						
		Pressure Drop		HC MBtu/h	Power kW	HE MBtu/h	LAT °F	COP	HWC MBtu/h	TC MBtu/h	SC MBtu/h	S/T Ratio	Power kW	HR MBtu/h	EER	HWC MBtu/h
		psi	ft/hd													
20	6.0	1.1	2.6	Operation not recommended												
	9.0	2.3	5.4	Operation not recommended												
	12.0	4.0	9.2	32.8	3.05	22.4	90.2	3.15	4.8	Operation not recommended						
30	6.0	1.1	2.5	Operation not recommended												
	9.0	2.3	5.3	37.5	3.13	26.8	93.1	3.51	5.2	49.7	34.1	0.69	1.90	52.0	26.1	---
	12.0	3.9	9.0	38.0	3.13	27.3	93.5	3.56	5.3	50.2	33.5	0.67	1.85	52.5	27.1	---
40	6.0	1.1	2.5	Operation not recommended												
	9.0	2.2	5.1	43.0	3.23	32.0	96.6	3.90	5.7	51.5	35.3	0.69	2.06	53.9	25.0	---
	12.0	3.8	8.7	43.8	3.24	32.7	97.0	3.96	5.8	52.1	35.3	0.68	2.01	54.4	25.9	---
50	6.0	1.0	2.4	46.2	3.26	35.1	98.5	4.16	6.2	52.5	36.7	0.70	2.35	54.9	22.3	3.1
	9.0	2.1	4.9	48.1	3.32	36.7	99.7	4.25	6.4	53.1	37.1	0.70	2.26	55.5	23.5	2.9
	12.0	3.7	8.4	49.0	3.33	37.7	100.3	4.31	6.5	53.6	37.1	0.69	2.20	56.0	24.4	2.8
60	6.0	1.0	2.3	50.8	3.33	39.5	101.4	4.48	7.0	51.1	36.3	0.71	2.58	53.5	19.8	3.7
	9.0	2.1	4.8	53.1	3.41	41.5	102.8	4.57	7.2	51.8	36.6	0.71	2.47	54.2	21.0	3.6
	12.0	3.5	8.2	54.4	3.43	42.7	103.6	4.64	7.4	52.3	36.6	0.70	2.40	54.7	21.8	3.4
70	6.0	1.0	2.2	55.5	3.41	43.9	104.3	4.78	7.9	50.8	36.7	0.72	2.86	53.2	17.8	4.7
	9.0	2.0	4.6	58.2	3.51	46.3	105.9	4.87	8.1	51.5	37.1	0.72	2.72	54.0	18.9	4.5
	12.0	3.4	7.9	59.7	3.54	47.7	106.9	4.95	8.3	52.1	37.1	0.71	2.65	54.5	19.6	4.2
80	6.0	0.9	2.1	59.4	3.46	47.5	106.6	5.03	8.8	48.5	35.9	0.74	3.17	51.0	15.3	5.9
	9.0	1.9	4.5	62.5	3.58	50.3	108.6	5.11	9.1	49.4	36.2	0.73	3.01	51.9	16.4	5.6
	12.0	3.3	7.6	64.3	3.62	51.9	109.7	5.20	9.4	49.9	36.2	0.73	2.93	52.4	17.0	5.4
90	6.0	0.9	2.1	63.2	3.52	51.2	109.0	5.26	9.9	45.1	34.2	0.76	3.50	47.7	12.9	7.4
	9.0	1.9	4.3	66.8	3.66	54.3	111.2	5.35	10.2	46.0	34.6	0.75	3.32	48.6	13.9	7.1
	12.0	3.2	7.4	68.9	3.71	56.2	112.5	5.44	10.6	46.5	34.6	0.74	3.23	49.0	14.4	6.7
100	6.0	0.9	2.0	Operation not recommended												
	9.0	1.8	4.2	Operation not recommended												
	12.0	3.1	7.1	Operation not recommended												
110	6.0	0.8	1.9	Operation not recommended												
	9.0	1.7	4.0	Operation not recommended												
	12.0	3.0	6.8	Operation not recommended												
120	6.0	0.8	1.8	Operation not recommended												
	9.0	1.7	3.8	Operation not recommended												
	12.0	2.8	6.6	Operation not recommended												

3/16/12

NB060 - Performance Data

Single Speed with PSC (2000 cfm)

EWT °F	Flow gpm	Water		HEATING - EAT 70°F						COOLING - EAT 80/67 °F						
		Pressure Drop		HC MBtu/h	Power kW	HE MBtu/h	LAT °F	COP	HWC MBtu/h	TC MBtu/h	SC MBtu/h	S/T Ratio	Power kW	HR MBtu/h	EER	HWC MBtu/h
		psi	ft/hd													
20	9.0	2.5	5.7	Operation not recommended												
	12.0	4.0	9.2	Operation not recommended												
	15.0	5.9	13.5	40.4	4.06	26.5	88.7	2.92	5.8	Operation not recommended						
30	9.0	2.4	5.5	Operation not recommended												
	12.0	3.9	8.9	45.4	4.06	31.5	91.0	3.28	6.2	68.8	47.6	0.69	2.91	71.2	23.7	---
	15.0	5.7	13.1	46.8	4.16	32.6	91.7	3.30	6.4	70.0	48.1	0.69	2.74	72.3	25.6	---
40	9.0	2.3	5.3	Operation not recommended												
	12.0	3.7	8.7	53.6	4.23	39.1	94.8	3.71	6.9	70.3	49.8	0.71	3.10	72.7	22.7	---
	15.0	5.5	12.7	54.8	4.30	40.1	95.4	3.73	7.1	71.1	49.6	0.70	2.95	73.5	24.1	---
50	9.0	2.2	5.2	58.9	4.35	44.1	97.3	3.97	7.5	71.4	50.5	0.71	3.44	73.8	20.8	4.1
	12.0	3.6	8.4	60.4	4.39	45.5	98.0	4.04	7.7	71.4	51.0	0.71	3.38	73.9	21.1	3.9
	15.0	5.3	12.3	61.5	4.43	46.4	98.5	4.07	7.9	72.2	51.0	0.71	3.23	74.6	22.3	3.7
60	9.0	2.2	5.0	65.4	4.47	50.1	100.3	4.29	8.4	69.1	49.4	0.71	3.63	71.5	19.0	5.0
	12.0	3.5	8.1	66.8	4.51	51.4	100.9	4.34	8.7	69.4	49.6	0.71	3.53	71.9	19.7	4.8
	15.0	5.2	11.9	68.7	4.58	53.1	101.8	4.40	8.9	69.8	49.9	0.71	3.41	72.2	20.5	4.6
70	9.0	2.1	4.9	72.0	4.60	56.3	103.4	4.59	9.5	67.8	49.4	0.73	3.97	70.3	17.1	6.3
	12.0	3.4	7.9	73.4	4.65	57.5	104.0	4.63	9.8	68.5	49.4	0.72	3.83	71.0	17.9	6.0
	15.0	5.0	11.6	76.1	4.74	59.9	105.2	4.71	10.0	68.5	49.9	0.73	3.73	71.0	18.4	5.7
80	9.0	2.0	4.7	76.7	4.71	60.7	105.5	4.78	10.7	64.8	48.0	0.74	4.35	67.3	14.9	8.0
	12.0	3.3	7.6	79.4	4.73	63.2	106.7	4.92	11.0	65.4	48.0	0.73	4.16	67.9	15.7	7.6
	15.0	4.8	11.2	81.5	4.87	64.9	107.7	4.91	11.3	65.8	48.5	0.74	4.05	68.3	16.2	7.2
90	9.0	2.0	4.5	81.6	4.83	65.2	107.8	4.96	12.0	60.3	45.8	0.76	4.74	62.9	12.7	10.0
	12.0	3.2	7.3	85.5	4.83	69.1	109.6	5.19	12.4	61.0	45.8	0.75	4.49	63.5	13.6	9.5
	15.0	4.7	10.8	87.2	5.02	70.1	110.4	5.09	12.8	61.6	46.3	0.75	4.37	64.1	14.1	9.1
100	9.0	1.9	4.4	Operation not recommended												
	12.0	3.1	7.1	Operation not recommended												
	15.0	4.5	10.4	Operation not recommended												
110	9.0	1.8	4.2	Operation not recommended												
	12.0	2.9	6.8	Operation not recommended												
	15.0	4.3	10.0	Operation not recommended												
120	9.0	1.7	4.0	Operation not recommended												
	12.0	2.8	6.5	Operation not recommended												
	15.0	4.2	9.6	Operation not recommended												

3/16/12

NB070 - Performance Data

Single Speed with PSC (2200 cfm)

EWT °F	Flow gpm	Water Pressure Drop		HEATING - EAT 70°F						COOLING - EAT 80/67 °F						
		psi	ft/hd	HC MBtu/h	Power kW	HE MBtu/h	LAT °F	COP	HWC MBtu/h	TC MBtu/h	SC MBtu/h	S/T Ratio	Power kW	HR MBtu/h	EER	HWC MBtu/h
20	12.0	3.0	7.0	Operation not recommended						Operation not recommended						
	15.0	4.4	10.2	Operation not recommended						Operation not recommended						
	18.0	6.0	13.9	46.9	4.62	31.2	89.8	2.98	6.9							
30	12.0	3.0	6.8	Operation not recommended						Operation not recommended						
	15.0	4.3	9.9	54.1	4.73	37.9	92.8	3.35	7.4	72.1	48.7	0.68	2.87	74.4	25.1	---
	18.0	5.8	13.5	54.3	4.75	38.1	92.8	3.35	7.6	72.5	49.1	0.68	2.86	74.8	25.3	---
40	12.0	2.9	6.6	Operation not recommended						Operation not recommended						
	15.0	4.1	9.6	63.1	4.89	46.4	96.5	3.78	8.2	75.8	52.8	0.70	3.11	78.2	24.4	---
	18.0	5.7	13.1	63.5	4.91	46.7	96.7	3.79	8.4	76.4	52.6	0.69	3.09	78.7	24.7	---
50	12.0	2.8	6.4	69.5	5.00	52.4	99.3	4.07	8.9	79.1	55.5	0.70	3.51	81.5	22.5	4.5
	15.0	4.0	9.3	70.9	5.04	53.7	99.9	4.13	9.2	79.5	55.7	0.70	3.41	81.9	23.3	4.3
	18.0	5.5	12.7	71.6	5.06	54.3	100.1	4.14	9.4	80.3	56.0	0.70	3.38	82.7	23.8	4.1
60	12.0	2.7	6.2	77.1	5.15	59.5	102.4	4.39	10.0	75.8	53.7	0.71	3.81	78.2	19.9	5.5
	15.0	3.9	9.0	79.3	5.21	61.6	103.4	4.47	10.3	76.1	53.9	0.71	3.70	78.6	20.6	5.2
	18.0	5.3	12.3	80.3	5.24	62.4	103.8	4.49	10.6	77.1	54.6	0.71	3.65	79.5	21.1	5.0
70	12.0	2.6	6.0	85.1	5.31	66.9	105.8	4.69	11.3	75.2	54.5	0.72	4.19	77.7	17.9	6.9
	15.0	3.8	8.7	88.2	5.39	69.8	107.1	4.79	11.6	75.5	54.6	0.72	4.08	78.0	18.5	6.6
	18.0	5.1	11.9	89.4	5.43	70.9	107.6	4.83	11.9	76.7	55.8	0.73	4.01	79.1	19.1	6.3
80	12.0	2.5	5.8	91.0	5.46	72.3	108.3	4.89	12.7	71.9	52.2	0.73	4.61	74.3	15.6	8.7
	15.0	3.6	8.4	95.1	5.56	76.2	110.0	5.01	13.1	72.1	52.2	0.72	4.49	74.6	16.1	8.3
	18.0	5.0	11.5	96.8	5.60	77.6	110.7	5.06	13.5	73.3	53.8	0.73	4.40	75.8	16.7	7.9
90	12.0	2.4	5.6	97.3	5.62	78.1	110.9	5.07	14.3	65.7	48.5	0.74	5.06	68.2	13.0	10.9
	15.0	3.5	8.1	102.5	5.75	82.9	113.1	5.23	14.7	65.9	48.4	0.73	4.93	68.4	13.4	10.4
	18.0	4.8	11.1	104.5	5.80	84.7	114.0	5.28	15.2	67.2	50.3	0.75	4.81	69.7	14.0	9.9
100	12.0	2.3	5.4	Operation not recommended						Operation not recommended						
	15.0	3.4	7.8	Operation not recommended						63.7	47.8	0.75	5.47	66.3	11.6	13.0
	18.0	4.6	10.7	Operation not recommended						65.1	50.2	0.77	5.33	67.7	12.2	12.3
110	12.0	2.2	5.2	Operation not recommended						Operation not recommended						
	15.0	3.3	7.5	Operation not recommended						56.2	42.5	0.76	6.03	58.8	9.3	15.9
	18.0	4.4	10.2	Operation not recommended						57.6	45.0	0.78	5.85	60.3	9.9	15.1
120	12.0	2.2	5.0	Operation not recommended						Operation not recommended						
	15.0	3.1	7.2	Operation not recommended						53.2	43.1	0.81	6.69	55.9	7.9	19.2
	18.0	4.3	9.8	Operation not recommended						54.6	46.0	0.84	6.47	57.5	8.4	18.2

3/16/12

NB015 - Performance Data

Single Speed with Variable Speed ECM or 5-Speed ECM (500 cfm)

EWT °F	Flow Rate gpm	Water		HEATING - EAT 70°F						COOLING - EAT 80/67 °F						
		Pressure Drop		Airflow cfm	HC MBtu/h	Power kW	HE MBtu/h	LAT °F	COP	Airflow cfm	TC MBtu/h	SC MBtu/h	S/T Ratio	Power kW	HR MBtu/h	EER
		psi	ft/hd													
20	2.0	0.6	1.4	Operation not recommended						Operation not recommended						
	3.0	1.6	3.7	Operation not recommended						Operation not recommended						
	4.0	2.7	6.1	400	10.2	0.94	7.0	91.6	3.19	Operation not recommended						
30	2.0	0.6	1.4	Operation not recommended						Operation not recommended						
				400	10.9	0.91	7.8	93.3	3.50	400	15.8	9.4	0.60	0.42	17.2	37.2
	3.0	1.6	3.7	500	11.3	0.93	8.1	88.8	3.54	500	16.2	10.5	0.65	0.46	17.7	35.6
				400	11.1	0.91	8.0	93.6	3.58	400	14.9	9.0	0.60	0.48	16.6	31.1
	4.0	2.6	6.1	500	11.4	0.93	8.2	89.1	3.61	500	15.3	10.0	0.65	0.52	17.1	29.7
40	2.0	0.6	1.4	Operation not recommended						Operation not recommended						
				400	12.0	0.93	8.9	95.9	3.78	400	16.2	9.8	0.61	0.49	17.9	33.2
	3.0	1.6	3.7	500	12.4	0.95	9.2	91.0	3.82	500	16.7	10.9	0.66	0.53	18.5	31.8
				400	12.4	0.93	9.2	96.6	3.89	400	15.9	9.7	0.61	0.50	17.6	32.0
	4.0	2.6	6.0	500	12.7	0.95	9.5	91.6	3.93	500	16.4	10.7	0.66	0.54	18.2	30.5
50	2.0	0.6	1.4	400	12.9	0.95	9.6	97.8	3.97	400	16.5	10.1	0.62	0.59	18.5	27.9
				500	13.3	0.97	10.0	92.6	4.01	500	16.9	11.3	0.67	0.64	19.1	26.7
	3.0	1.6	3.7	400	13.3	0.95	10.0	98.7	4.08	400	16.7	10.2	0.61	0.55	18.6	30.2
				500	13.7	0.97	10.4	93.3	4.12	500	17.1	11.4	0.66	0.60	19.2	28.8
	4.0	2.6	6.0	400	13.6	0.96	10.4	99.6	4.19	400	16.9	10.3	0.61	0.52	18.7	32.8
500	14.1	0.98	10.7	94.1	4.23	500	17.4	11.5	0.66	0.56	19.3	31.3				
60	2.0	0.6	1.4	400	14.2	0.97	10.9	101.0	4.31	400	15.6	9.8	0.63	0.68	18.0	23.0
				500	14.7	0.99	11.3	95.2	4.36	500	16.1	10.9	0.68	0.73	18.6	22.0
	3.0	1.6	3.7	400	14.7	0.97	11.4	102.0	4.43	400	15.9	9.9	0.62	0.64	18.0	24.7
				500	15.2	0.99	11.8	96.1	4.47	500	16.3	11.0	0.67	0.69	18.7	23.6
	4.0	2.6	6.0	400	15.2	0.98	11.8	103.1	4.53	400	16.1	10.0	0.62	0.60	18.1	26.6
500	15.6	1.00	12.2	96.9	4.58	500	16.5	11.1	0.67	0.65	18.7	25.4				
70	2.0	0.6	1.4	400	15.6	0.98	12.2	104.1	4.64	400	14.8	9.5	0.64	0.77	17.4	19.3
				500	16.1	1.01	12.7	97.8	4.69	500	15.2	10.5	0.69	0.83	18.1	18.5
	3.0	1.6	3.7	400	16.1	0.99	12.7	105.4	4.76	400	15.0	9.5	0.63	0.73	17.5	20.6
				500	16.6	1.02	13.2	98.8	4.81	500	15.4	10.6	0.69	0.79	18.1	19.7
	4.0	2.6	6.0	400	16.7	1.00	13.2	106.6	4.87	400	15.2	9.6	0.63	0.69	17.6	22.0
500	17.2	1.03	13.7	99.8	4.92	500	15.7	10.6	0.68	0.75	18.2	21.0				
80	2.0	0.6	1.4	400	17.2	1.00	13.8	107.8	5.03	400	14.1	9.2	0.65	0.88	17.1	16.1
				500	17.7	1.02	14.2	100.8	5.08	500	14.5	10.2	0.70	0.94	17.7	15.3
	3.0	1.6	3.7	400	17.8	1.02	14.4	109.3	5.14	400	14.3	9.2	0.64	0.84	17.1	17.0
				500	18.4	1.04	14.8	102.0	5.20	500	14.7	10.2	0.70	0.90	17.8	16.2
	4.0	2.6	5.9	400	18.2	1.02	14.7	110.2	5.21	400	14.5	9.3	0.64	0.79	17.2	18.3
500	18.8	1.05	15.2	102.8	5.27	500	14.9	10.4	0.70	0.85	17.8	17.5				
90	2.0	0.6	1.4	400	18.9	1.02	15.5	111.8	5.44	400	13.4	8.9	0.66	1.00	16.8	13.4
				500	19.5	1.04	16.0	104.2	5.50	500	13.7	9.9	0.72	1.07	17.4	12.8
	3.0	1.6	3.6	400	19.7	1.04	16.1	113.5	5.55	400	13.5	8.9	0.65	0.97	16.8	14.0
				500	20.3	1.06	16.7	105.6	5.61	500	13.9	9.8	0.71	1.04	17.5	13.4
	4.0	2.6	5.9	400	19.8	1.04	16.2	113.7	5.55	400	13.8	9.1	0.66	0.89	16.8	15.5
500	20.4	1.07	16.7	105.7	5.61	500	14.2	10.1	0.71	0.96	17.4	14.8				
100	2.0	0.6	1.4	Operation not recommended						Operation not recommended						
	3.0	1.6	3.6	Operation not recommended						400	12.9	8.5	0.66	1.11	16.6	11.6
				500	13.2	9.5	0.72	1.19	17.3	11.1						
	4.0	2.5	5.9	Operation not recommended						400	12.9	8.8	0.68	1.00	16.3	13.0
500				13.3	9.8	0.74	1.07	16.9	12.4							
110	2.0	0.6	1.4	Operation not recommended						Operation not recommended						
	3.0	1.6	3.6	Operation not recommended						400	12.2	8.2	0.68	1.27	16.5	9.6
				500	12.5	9.2	0.73	1.37	17.2	9.1						
	4.0	2.5	5.9	Operation not recommended						400	12.1	8.5	0.71	1.10	15.8	11.0
500				12.4	9.5	0.76	1.19	16.5	10.5							
120	2.0	0.6	1.4	Operation not recommended						Operation not recommended						
	3.0	1.6	3.6	Operation not recommended						400	11.6	8.0	0.69	1.46	16.6	7.9
				500	11.9	8.8	0.74	1.57	17.3	7.6						
	4.0	2.5	5.8	Operation not recommended						400	10.9	8.3	0.76	1.22	15.1	8.9
500				11.2	9.2	0.82	1.32	15.7	8.5							

NB018 - Performance Data

Single Speed with Variable Speed ECM or 5-Speed ECM (600 cfm)

EWT °F	Flow Rate gpm	Water Pressure Drop		Heating - EAT 70°F							Cooling - EAT 80/67 °F							
		psi	ft/hd	Airflow cfm	HC MBtu/h	Power kW	HE MBtu/h	LAT °F	COP	HWC MBtu/h	Airflow cfm	TC MBtu/h	SC MBtu/h	S/T Ratio	Power kW	HR MBtu/h	EER	HWC MBtu/h
20	3.0	1.8	4.1	Operation not recommended														
	4.0	3.0	6.9	Operation not recommended														
	5.0	4.3	9.9	500	12.3	1.09	8.6	90.8	3.30	1.6	Operation not recommended							
				600	12.7	1.12	8.9	87.6	3.34	1.5	Operation not recommended							
30	3.0	1.7	3.9	Operation not recommended							Operation not recommended							
	4.0	3.0	6.8	500	13.9	1.16	10.0	93.8	3.51	1.6	500	19.0	11.6	0.61	0.65	21.2	29.4	--
				600	14.4	1.19	10.3	90.2	3.55	1.6	600	19.5	12.9	0.66	0.70	21.9	28.1	--
				500	14.2	1.17	10.2	94.2	3.54	1.7	500	18.3	11.2	0.61	0.63	20.4	29.1	--
				600	14.6	1.20	10.5	90.5	3.58	1.6	600	18.8	12.4	0.66	0.68	21.1	27.9	--
5.0	4.2	9.7	Operation not recommended							Operation not recommended								
40	3.0	1.7	3.8	Operation not recommended							Operation not recommended							
	4.0	2.9	6.7	500	15.4	1.22	11.2	96.5	3.70	1.8	500	19.4	11.7	0.60	0.69	21.8	28.0	--
				600	15.9	1.24	11.6	92.5	3.74	1.6	600	20.0	13.0	0.65	0.75	22.5	26.8	--
				500	15.8	1.23	11.6	97.2	3.76	1.8	500	19.2	11.5	0.60	0.64	21.4	29.9	--
				600	16.3	1.26	12.0	93.1	3.79	1.7	600	19.8	12.8	0.65	0.69	22.1	28.6	--
5.0	4.2	9.6	Operation not recommended							Operation not recommended								
50	3.0	1.6	3.7	500	16.6	1.27	12.3	98.7	3.83	1.9	500	19.6	11.9	0.61	0.82	22.4	23.8	0.9
				600	17.1	1.30	12.7	94.4	3.87	1.7	600	20.1	13.2	0.66	0.89	23.1	22.7	1.0
	4.0	2.9	6.6	500	17.0	1.28	12.6	99.4	3.89	1.9	500	19.8	11.8	0.60	0.74	22.4	26.8	0.8
				600	17.5	1.31	13.0	95.0	3.93	1.8	600	20.4	13.2	0.64	0.80	23.1	25.7	0.9
				500	17.4	1.29	13.0	100.2	3.95	1.9	500	20.1	11.8	0.59	0.66	22.4	30.7	0.8
				600	17.9	1.32	13.4	95.6	3.99	1.9	600	20.7	13.1	0.63	0.71	23.1	29.4	0.9
5.0	4.2	9.6	Operation not recommended							Operation not recommended								
60	3.0	1.6	3.6	500	18.5	1.33	13.9	102.2	4.08	2.1	500	18.7	11.4	0.61	0.87	21.6	21.5	1.0
				600	19.1	1.36	14.4	97.4	4.12	2.0	600	19.2	12.7	0.66	0.94	22.4	20.5	1.1
	4.0	2.8	6.6	500	18.8	1.34	14.3	102.9	4.11	2.1	500	18.9	11.4	0.60	0.81	21.7	23.2	1.0
				600	19.4	1.37	14.8	98.0	4.16	2.0	600	19.4	12.6	0.65	0.88	22.4	22.2	1.1
				500	19.2	1.36	14.6	103.6	4.15	2.2	500	19.1	11.3	0.59	0.76	21.7	25.2	0.9
				600	19.8	1.39	15.1	98.6	4.19	2.0	600	19.6	12.6	0.64	0.82	22.4	24.0	1.0
5.0	4.1	9.5	Operation not recommended							Operation not recommended								
70	3.0	1.5	3.5	500	20.4	1.39	15.6	105.7	4.31	2.4	500	17.8	10.9	0.61	0.92	20.9	19.4	1.2
				600	21.0	1.42	16.2	100.4	4.35	2.2	600	18.3	12.1	0.66	0.99	21.7	18.6	1.3
	4.0	2.8	6.5	500	20.7	1.41	15.9	106.4	4.32	2.4	500	17.9	10.9	0.61	0.89	20.9	20.2	1.1
				600	21.4	1.44	16.5	100.9	4.36	2.2	600	18.4	12.1	0.66	0.96	21.7	19.3	1.3
				500	21.0	1.43	16.2	107.0	4.33	2.4	500	18.0	10.9	0.60	0.86	20.9	20.9	1.1
				600	21.7	1.46	16.7	101.5	4.37	2.2	600	18.5	12.1	0.65	0.93	21.7	20.0	1.2
5.0	4.1	9.5	Operation not recommended							Operation not recommended								
80	3.0	1.5	3.4	500	22.6	1.45	17.7	109.9	4.57	2.7	500	17.0	10.4	0.61	0.97	20.3	17.6	1.6
				600	23.3	1.48	18.3	104.0	4.62	2.5	600	17.5	11.6	0.66	1.04	21.0	16.8	1.7
	4.0	2.8	6.4	500	22.9	1.48	17.9	110.4	4.55	2.7	500	17.0	10.4	0.61	0.97	20.3	17.5	1.5
				600	23.6	1.51	18.5	104.5	4.60	2.4	600	17.5	11.6	0.66	1.05	21.1	16.7	1.6
				500	23.3	1.49	18.2	111.1	4.58	2.7	500	17.2	10.6	0.62	0.95	20.4	18.1	1.4
				600	24.0	1.52	18.8	105.0	4.63	2.5	600	17.7	11.8	0.67	1.02	21.1	17.3	1.5
5.0	4.1	9.4	Operation not recommended							Operation not recommended								
90	3.0	1.4	3.2	500	25.1	1.52	19.9	114.4	4.85	3.0	500	16.2	10.0	0.62	1.02	19.7	15.9	1.9
				600	25.8	1.55	20.6	107.9	4.90	2.8	600	16.7	11.1	0.67	1.10	20.4	15.2	2.1
	4.0	2.7	6.3	500	25.3	1.55	20.0	114.9	4.79	3.0	500	16.2	10.0	0.62	1.07	19.8	15.1	1.8
				600	26.1	1.58	20.7	108.3	4.84	2.8	600	16.6	11.1	0.67	1.15	20.5	14.5	2.0
				500	25.5	1.55	20.2	115.2	4.81	3.1	500	16.3	10.3	0.63	1.04	19.9	15.7	1.7
				600	26.3	1.59	20.9	108.6	4.86	2.9	600	16.8	11.4	0.68	1.12	20.6	15.0	1.9
5.0	4.0	9.2	Operation not recommended							Operation not recommended								
100	3.0	1.4	3.1	Operation not recommended							Operation not recommended							
	4.0	2.7	6.2	500	15.3	9.6	0.63	1.17	19.3	13.1	2.2	Operation not recommended						
				600	15.8	10.7	0.68	1.26	20.1	12.5	2.4	Operation not recommended						
				500	15.3	9.9	0.65	1.19	19.4	12.9	2.0	Operation not recommended						
600	15.8	11.1	0.70	1.28	20.1	12.3	2.3	Operation not recommended										
110	3.0	1.3	3.0	Operation not recommended							Operation not recommended							
	4.0	2.7	6.1	500	14.6	9.2	0.63	1.28	19.0	11.4	2.9	Operation not recommended						
				600	15.0	10.2	0.68	1.38	19.7	10.9	3.2	Operation not recommended						
				500	14.3	9.6	0.67	1.33	18.9	10.7	2.6	Operation not recommended						
600	14.7	10.7	0.73	1.44	19.6	10.2	3.0	Operation not recommended										
120	3.0	1.3	2.9	Operation not recommended							Operation not recommended							
	4.0	2.6	6.1	500	13.8	8.8	0.64	1.41	18.6	9.8	3.5	Operation not recommended						
				600	14.2	9.8	0.69	1.51	19.4	9.4	4.0	Operation not recommended						
				500	13.3	9.2	0.69	1.48	18.4	9.0	3.1	Operation not recommended						
600	13.7	10.2	0.74	1.60	19.1	8.6	3.5	Operation not recommended										

NB024 - Performance Data

Single Speed with Variable Speed ECM or 5-Speed ECM (800 cfm)

EWT °F	Flow Rate gpm	Water Pressure Drop		Heating - EAT 70°F							Cooling - EAT 80/67 °F							
		psi	ft/hd	Airflow cfm	HC MBtu/h	Power kW	HE MBtu/h	LAT °F	COP	HWC MBtu/h	Airflow cfm	TC MBtu/h	SC MBtu/h	S/T Ratio	Power kW	HR MBtu/h	EER	HWC MBtu/h
20	3.0	1.2	2.8	Operation not recommended							Operation not recommended							
	4.5	2.1	4.9	Operation not recommended							Operation not recommended							
	6.0	4.2	9.7	600	15.0	1.42	10.3	87.3	3.14	1.7	Operation not recommended							
800				15.4	1.43	10.5	85.8	3.16	1.6	Operation not recommended								
30	3.0	1.1	2.6	Operation not recommended							Operation not recommended							
	4.5	2.1	4.9	600	19.0	1.50	13.7	92.4	3.69	1.8	600	26.1	15.1	0.61	0.87	29.1	30.0	---
				800	19.1	1.51	14.0	90.1	3.72	1.7	800	26.5	17.0	0.64	0.92	29.7	29.0	---
	6.0	4.1	9.5	600	18.7	1.51	13.4	91.2	3.62	1.8	600	26.6	15.2	0.61	0.82	29.2	30.8	---
				800	18.9	1.52	13.7	89.9	3.64	1.7	800	26.9	17.3	0.64	0.86	29.8	30.0	---
40	3.0	1.1	2.5	Operation not recommended							Operation not recommended							
	4.5	2.0	4.6	600	21.0	1.54	15.8	95.1	4.01	2.0	600	27.2	16.4	0.64	0.89	30.1	29.7	---
				800	21.3	1.55	16.1	92.7	4.04	1.9	800	27.6	18.4	0.67	0.95	30.8	29.0	---
	6.0	4.1	9.5	600	21.4	1.56	16.1	96.0	4.03	2.0	600	27.4	16.5	0.64	0.87	30.2	30.5	---
				800	21.7	1.57	16.4	93.1	4.06	1.9	800	27.7	18.5	0.67	0.93	30.9	29.8	---
50	3.0	1.1	2.5	600	22.5	1.56	17.2	96.8	4.25	2.2	600	28.0	17.8	0.65	0.93	31.2	30.1	1.2
				800	23.0	1.57	17.6	94.6	4.29	2.1	800	28.8	19.9	0.69	0.98	32.1	29.4	1.3
	4.5	2.0	4.6	600	23.4	1.58	18.0	97.9	4.32	2.2	600	28.1	17.8	0.65	0.94	31.1	29.5	1.1
				800	23.8	1.59	18.3	95.5	4.38	2.1	800	28.7	19.8	0.69	0.99	32.0	28.9	1.2
	6.0	4.0	9.3	600	24.0	1.60	18.6	98.8	4.41	2.3	600	27.9	17.6	0.65	0.95	31.0	29.1	1.1
800				24.5	1.61	19.0	96.4	4.46	2.2	800	28.5	19.6	0.69	1.00	31.9	28.5	1.2	
60	3.0	1.0	2.2	600	25.4	1.61	20.0	100.2	4.62	2.4	600	27.3	17.4	0.68	1.01	30.8	26.3	1.4
				800	25.9	1.62	20.3	97.9	4.69	2.3	800	27.8	19.4	0.70	1.09	31.5	25.5	1.5
	4.5	1.9	4.4	600	26.2	1.63	20.7	101.0	4.73	2.5	600	27.3	17.4	0.68	1.07	30.9	25.5	1.3
				800	26.7	1.64	21.1	98.8	4.78	2.4	800	27.8	19.4	0.70	1.12	31.6	24.8	1.4
	6.0	3.9	9.0	600	27.0	1.65	21.4	102.4	4.82	2.5	600	27.3	17.3	0.67	1.09	31.0	25.3	1.3
800				27.5	1.66	21.8	99.8	4.86	2.4	800	27.8	19.3	0.69	1.15	31.7	24.2	1.4	
70	3.0	0.9	2.1	600	28.2	1.65	22.4	103.6	5.02	2.7	600	26.2	16.8	0.69	1.12	31.1	22.9	1.7
				800	28.7	1.66	23.0	101.2	5.07	2.6	800	26.7	18.9	0.71	1.20	30.8	22.3	1.8
	4.5	1.8	4.2	600	29.1	1.67	23.5	104.6	5.11	2.7	600	26.3	17.2	0.68	1.17	30.3	22.0	1.7
				800	29.6	1.68	23.8	102.2	5.16	2.6	800	26.9	19.0	0.70	1.25	31.2	21.5	1.8
	6.0	3.8	8.7	600	30.0	1.69	24.0	105.7	5.19	2.8	600	26.5	17.2	0.68	1.21	30.7	21.1	1.6
800				30.4	1.70	24.6	103.2	5.24	2.7	800	27.1	19.0	0.70	1.30	31.5	20.8	1.7	
80	3.0	0.8	1.9	600	31.2	1.72	25.2	106.4	5.32	3.0	600	24.5	16.6	0.71	1.45	29.5	15.9	2.2
				800	31.8	1.73	25.9	104.8	5.38	2.9	800	24.9	18.5	0.74	1.58	30.3	15.7	2.3
	4.5	1.7	3.9	600	32.0	1.74	26.1	107.9	5.39	3.0	600	25.0	16.5	0.70	1.42	29.7	17.0	2.1
				800	32.5	1.75	26.5	105.6	5.43	2.9	800	25.4	18.6	0.73	1.51	30.5	16.8	2.2
	6.0	3.7	8.5	600	31.8	1.77	26.6	108.8	5.42	3.1	600	25.2	16.5	0.70	1.34	29.8	18.1	2.0
800				33.2	1.78	27.1	106.4	5.48	3.0	800	25.7	18.7	0.73	1.46	30.7	17.6	2.1	
90	3.0	0.8	1.7	600	34.0	1.79	28.2	110.8	5.62	3.4	600	22.8	15.9	0.75	1.64	28.7	13.6	2.7
				800	34.5	1.80	28.8	108.4	5.67	3.3	800	23.1	18.1	0.78	1.75	29.1	13.2	2.8
	4.5	1.7	3.9	600	35.0	1.82	28.8	111.4	5.63	3.5	600	23.2	15.9	0.74	1.58	28.8	14.3	2.5
				800	35.5	1.83	29.2	109.0	5.69	3.4	800	23.8	18.2	0.76	1.67	29.5	14.2	2.7
	6.0	3.7	8.5	600	35.8	1.84	29.3	112.0	5.65	3.6	600	23.8	15.8	0.74	1.55	29.1	15.5	2.4
800				36.0	1.85	29.7	109.7	5.70	3.5	800	24.3	18.4	0.76	1.62	29.8	15.0	2.5	
100	3.0	0.7	1.6	Operation not recommended							Operation not recommended							
	4.5	1.6	3.7	Operation not recommended							600	22.0	15.7	0.76	1.64	27.9	13.1	3.3
				800	22.4	15.4	0.77	1.61	28.0	13.6	3.1							
6.0	3.6	8.3	Operation not recommended							600	22.4	15.4	0.77	1.61	28.0	13.6	3.1	
110	3.0	0.6	1.4	Operation not recommended							Operation not recommended							
				Operation not recommended							600	20.3	14.7	0.79	1.70	26.4	11.4	3.9
	4.5	1.5	3.5	Operation not recommended							600	20.8	16.8	0.81	1.85	27.1	11.2	4.1
				800	20.8	14.6	0.79	1.65	26.5	12.1	3.7							
	6.0	3.5	8.1	Operation not recommended							600	21.2	17.1	0.81	1.80	27.3	11.8	3.9
800				21.2	17.1	0.81	1.80	27.3	11.8	3.9								
120	3.0	0.6	1.3	Operation not recommended							Operation not recommended							
	4.5	1.5	3.5	Operation not recommended							600	18.3	14.1	0.84	2.19	25.9	8.8	4.8
				800	18.9	16.3	0.86	2.37	27.0	8.0	4.9							
	6.0	3.5	8.1	Operation not recommended							600	19.0	14.3	0.81	2.17	26.1	8.9	4.5
800				19.3	16.5	0.85	2.30	27.1	8.4	4.6								

NB030 - Performance Data

Single Speed with Variable Speed ECM or 5-Speed ECM (900 cfm)

EWT °F	Flow Rate gpm	Water Pressure Drop		HEATING - EAT 70°F							COOLING - EAT 80/67 °F								
		psi	ft/hd	Airflow cfm	HC MBtu/h	Power kW	HE MBtu/h	LAT °F	COP	HWC MBtu/h	Airflow cfm	TC MBtu/h	SC MBtu/h	S/T Ratio	Power kW	HR MBtu/h	EER	HWC MBtu/h	
20	4.0	1.4	3.5	Operation not recommended							Operation not recommended								
	6.0	2.8	7.2	Operation not recommended							Operation not recommended								
	8.0	4.6	12.1	700	16.9	1.52	11.7	92.4	3.26	2.2	Operation not recommended								
				900	17.2	1.55	11.9	87.7	3.25	2.0	Operation not recommended								
30	4.0	1.4	3.4	Operation not recommended							Operation not recommended								
	6.0	2.7	7.0	700	19.4	1.51	14.2	95.7	3.77	2.4	700	26.1	16.7	0.64	0.87	29.1	30.0	---	
				900	19.8	1.54	14.6	90.4	3.77	2.2	900	26.8	18.7	0.70	0.94	30.0	28.5	---	
	8.0	4.4	11.8	700	19.9	1.53	14.7	96.3	3.82	2.4	700	26.3	16.7	0.63	0.85	29.2	30.8	---	
				900	20.2	1.56	14.9	90.8	3.81	2.2	900	27.3	18.7	0.68	0.91	30.4	30.0	---	
40	4.0	1.3	3.3	Operation not recommended							Operation not recommended								
	6.0	2.6	6.8	700	22.7	1.56	17.4	100.1	4.27	2.6	700	28.3	18.0	0.64	0.95	31.5	29.7	---	
				900	23.3	1.58	17.9	93.9	4.31	2.4	900	29.1	20.2	0.70	1.02	32.6	28.4	---	
				700	23.3	1.58	17.9	100.8	4.32	2.7	700	28.5	18.0	0.63	0.93	31.7	30.5	---	
	8.0	4.3	11.4	900	23.8	1.60	18.3	94.5	4.36	2.5	900	29.5	20.2	0.68	0.99	32.9	29.7	---	
50	4.0	1.3	3.2	700	24.9	1.60	19.4	102.9	4.55	2.8	700	30.2	19.3	0.64	1.10	34.0	27.5	1.4	
				900	25.5	1.62	20.0	96.2	4.61	2.6	900	31.1	21.7	0.70	1.17	35.1	26.6	1.5	
	6.0	2.5	6.6	700	25.7	1.61	20.2	104.0	4.68	2.9	700	30.3	19.5	0.64	1.06	33.9	28.6	1.3	
				900	26.4	1.63	20.8	97.1	4.75	2.7	900	31.2	21.8	0.70	1.13	35.0	27.7	1.4	
	8.0	4.2	11.1	700	26.3	1.63	20.7	104.8	4.72	3.0	700	30.6	19.5	0.64	1.04	34.1	29.5	1.2	
			900	26.9	1.64	21.3	97.7	4.81	2.8	900	31.6	21.8	0.69	1.10	35.3	28.7	1.4		
60	4.0	1.2	3.1	700	27.9	1.67	22.2	107.0	4.90	3.2	700	29.5	18.9	0.64	1.21	33.6	24.4	1.7	
				900	28.7	1.67	23.0	99.5	5.02	3.0	900	30.4	21.3	0.70	1.28	34.7	23.7	1.8	
	6.0	2.4	6.4	700	28.9	1.69	23.1	108.2	5.01	3.3	700	29.6	19.1	0.65	1.16	33.5	25.4	1.6	
				900	29.7	1.69	23.9	100.6	5.16	3.0	900	30.5	21.3	0.70	1.23	34.7	24.7	1.7	
	8.0	4.0	10.7	700	29.5	1.71	23.6	109.0	5.05	3.4	700	29.9	19.1	0.64	1.14	33.8	26.2	1.5	
			900	30.3	1.70	24.5	101.1	5.21	3.1	900	30.8	21.4	0.69	1.20	34.9	25.6	1.6		
70	4.0	1.2	3.0	700	31.1	1.76	25.1	111.1	5.19	3.6	700	29.7	19.2	0.65	1.35	34.3	22.0	2.1	
				900	32.0	1.75	26.0	102.9	5.36	3.3	900	30.6	21.6	0.71	1.42	35.4	21.5	2.2	
	6.0	2.4	6.2	700	32.1	1.78	26.0	112.5	5.28	3.7	700	29.7	19.3	0.65	1.30	34.2	22.9	2.0	
				900	33.1	1.76	27.1	104.1	5.50	3.4	900	30.6	21.6	0.70	1.37	35.3	22.4	2.1	
	8.0	3.9	10.4	700	32.7	1.81	26.5	113.2	5.31	3.8	700	30.1	19.3	0.64	1.27	34.4	23.6	1.8	
			900	33.7	1.78	27.6	104.6	5.53	3.5	900	31.0	21.7	0.70	1.34	35.5	23.1	2.0		
80	4.0	1.2	2.9	700	33.6	1.84	27.3	114.4	5.36	4.0	700	28.4	19.0	0.67	1.51	33.6	18.9	2.6	
				900	34.7	1.81	28.5	105.7	5.61	3.7	900	29.3	21.3	0.73	1.58	34.7	18.5	2.8	
	6.0	2.3	5.9	700	34.8	1.87	28.4	116.0	5.46	4.1	700	28.6	19.1	0.67	1.45	33.5	19.7	2.5	
				900	36.0	1.83	29.7	107.0	5.75	3.8	900	29.4	21.3	0.72	1.52	34.6	19.4	2.7	
	8.0	3.8	10.0	700	35.3	1.89	28.9	116.7	5.47	4.3	700	28.8	19.1	0.66	1.42	33.7	20.3	2.3	
			900	36.5	1.85	30.2	107.6	5.77	3.9	900	29.7	21.4	0.72	1.49	34.8	19.9	2.5		
90	4.0	1.1	2.8	700	36.2	1.94	29.6	117.8	5.47	4.5	700	26.3	18.0	0.68	1.68	32.0	15.6	3.3	
				900	37.4	1.89	31.0	108.5	5.80	4.2	900	27.1	20.1	0.74	1.75	33.1	15.5	3.5	
	6.0	2.2	5.7	700	37.5	1.97	30.8	119.6	5.59	4.6	700	26.5	18.0	0.68	1.62	32.0	16.4	3.1	
				900	38.9	1.92	32.3	110.0	5.93	4.3	900	27.3	20.1	0.74	1.68	33.0	16.2	3.3	
	8.0	3.6	9.6	700	38.0	2.00	31.2	120.3	5.58	4.8	700	26.7	18.1	0.68	1.58	32.1	16.9	2.8	
			900	39.5	1.94	32.8	110.6	5.95	4.4	900	27.6	20.2	0.73	1.65	33.2	16.7	3.2		
100	4.0	1.1	2.7	Operation not recommended							Operation not recommended								
	6.0	2.1	5.5	Operation not recommended							Operation not recommended								
	8.0	3.5	9.3	Operation not recommended							Operation not recommended								
				700	25.3	18.0	0.71	1.83	31.5	13.8	3.8	700	25.3	18.0	0.71	1.83	31.5	13.8	3.8
110	4.0	1.0	2.6	Operation not recommended							Operation not recommended								
	6.0	2.0	5.3	Operation not recommended							Operation not recommended								
	8.0	3.4	8.9	Operation not recommended							Operation not recommended								
				700	21.5	16.9	0.79	2.04	28.5	10.6	4.6	700	21.5	16.9	0.79	2.04	28.5	10.6	4.6
				900	22.2	18.8	0.85	2.10	29.3	10.6	5.0	900	22.2	18.8	0.85	2.10	29.3	10.6	5.0
120	4.0	1.0	2.5	Operation not recommended							Operation not recommended								
	6.0	2.0	5.1	Operation not recommended							Operation not recommended								
	8.0	3.2	8.6	Operation not recommended							Operation not recommended								
				700	20.8	16.3	0.78	2.30	28.7	9.1	5.5	700	20.8	16.3	0.78	2.30	28.7	9.1	5.5
				900	21.4	18.1	0.85	2.35	29.5	9.1	6.0	900	21.4	18.1	0.85	2.35	29.5	9.1	6.0
			700	20.9	16.4	0.78	2.25	28.6	9.3	5.1	700	20.9	16.4	0.78	2.25	28.6	9.3	5.1	
			900	21.7	18.2	0.84	2.30	29.5	9.4	5.7	900	21.7	18.2	0.84	2.30	29.5	9.4	5.7	

NB036 - Performance Data

Single Speed with Variable Speed ECM or 5-Speed ECM (1250 cfm)

EWT °F	Flow Rate gpm	Water Pressure Drop		HEATING - EAT 70°F							COOLING - EAT 80/67 °F							
		psi	ft/hd	Airflow cfm	HC MBtu/h	Power kW	HE MBtu/h	LAT °F	COP	HWC MBtu/h	Airflow cfm	TC MBtu/h	SC MBtu/h	S/T Ratio	Power kW	HR MBtu/h	EER	HWC MBtu/h
20	5.0	1.0	2.4	Operation not recommended							Operation not recommended							
	7.0	2.1	4.9	Operation not recommended							Operation not recommended							
	9.0	3.6	8.2	1050	21.0	1.83	14.8	88.5	3.36	2.7	Operation not recommended							
				1250	21.4	1.87	15.0	85.8	3.35	2.4	Operation not recommended							
30	5.0	1.0	2.3	Operation not recommended							Operation not recommended							
	7.0	2.1	4.7	1050	23.6	1.84	17.3	90.8	3.76	2.9	1050	30.2	19.5	0.65	1.05	33.8	28.6	---
				1250	24.1	1.88	17.7	87.8	3.76	2.6	1250	31.0	21.9	0.70	1.14	34.9	27.2	---
	9.0	3.5	8.0	1050	24.2	1.86	17.9	91.3	3.82	3.0	1050	30.4	19.4	0.64	1.04	34.0	29.4	---
1250				24.6	1.89	18.1	88.2	3.81	2.7	1250	31.5	21.8	0.69	1.10	35.3	28.7	---	
40	5.0	1.0	2.3	Operation not recommended							Operation not recommended							
	7.0	2.0	4.6	1050	27.4	1.89	20.9	94.2	4.24	3.2	1050	33.1	21.7	0.66	1.15	37.0	28.7	---
				1250	28.0	1.92	21.5	90.8	4.28	3.0	1250	34.0	24.3	0.71	1.24	38.3	27.5	---
	9.0	3.4	7.8	1050	28.0	1.92	21.5	94.7	4.29	3.3	1050	33.4	21.6	0.65	1.13	37.2	29.5	---
1250				28.6	1.94	22.0	91.2	4.33	3.0	1250	34.5	24.3	0.70	1.20	38.6	28.7	---	
50	5.0	1.0	2.2	1050	29.8	1.94	23.2	96.3	4.52	3.5	1050	35.6	23.4	0.66	1.33	40.2	26.8	1.7
				1250	30.5	1.95	23.8	92.6	4.58	3.2	1250	36.7	26.3	0.72	1.41	41.5	26.0	1.8
	7.0	1.9	4.5	1050	30.8	1.94	24.2	97.1	4.64	3.6	1050	35.7	23.6	0.66	1.28	40.1	27.9	1.6
				1250	31.6	1.96	24.9	93.4	4.72	3.3	1250	36.8	26.4	0.72	1.36	41.4	27.0	1.7
9.0	3.3	7.5	1050	31.5	1.97	24.7	97.7	4.68	3.7	1050	36.1	23.6	0.65	1.25	40.4	28.8	1.4	
			1250	32.2	1.98	25.5	93.9	4.78	3.4	1250	37.2	26.4	0.71	1.33	41.8	28.0	1.6	
60	5.0	0.9	2.1	1050	33.4	1.99	26.6	99.4	4.92	3.9	1050	35.4	24.0	0.68	1.45	40.3	24.4	2.0
				1250	34.3	1.99	27.5	95.4	5.04	3.6	1250	36.4	26.9	0.74	1.54	41.7	23.7	2.1
	7.0	1.9	4.3	1050	34.5	2.01	27.6	100.4	5.03	4.0	1050	35.4	24.1	0.68	1.40	40.2	25.4	1.9
				1250	35.5	2.01	28.6	96.3	5.18	3.7	1250	36.5	27.0	0.74	1.48	41.6	24.7	2.0
9.0	3.1	7.3	1050	35.2	2.04	28.2	101.0	5.06	4.2	1050	35.8	24.1	0.67	1.37	40.5	26.2	1.7	
			1250	36.2	2.03	29.2	96.8	5.23	3.8	1250	36.9	27.0	0.73	1.45	41.9	25.6	1.9	
70	5.0	0.9	2.1	1050	37.1	2.05	30.1	102.8	5.31	4.4	1050	35.9	24.9	0.69	1.61	41.3	22.3	2.5
				1250	38.2	2.04	31.3	98.3	5.48	4.1	1250	36.9	28.0	0.76	1.70	42.7	21.8	2.6
	7.0	1.8	4.2	1050	38.4	2.09	31.3	103.9	5.40	4.5	1050	36.0	25.0	0.70	1.55	41.2	23.2	2.3
				1250	39.6	2.06	32.6	99.3	5.63	4.2	1250	37.0	28.0	0.76	1.63	42.6	22.7	2.5
9.0	3.0	7.0	1050	39.1	2.11	31.9	104.5	5.43	4.7	1050	36.3	25.0	0.69	1.52	41.5	24.0	2.2	
			1250	40.3	2.09	33.2	99.8	5.66	4.3	1250	37.4	28.1	0.75	1.60	42.9	23.4	2.4	
80	5.0	0.9	2.0	1050	40.1	2.11	32.9	105.4	5.57	4.9	1050	35.0	24.8	0.71	1.78	41.0	19.6	3.1
				1250	41.4	2.08	34.3	100.7	5.83	4.6	1250	36.0	27.8	0.77	1.87	42.4	19.3	3.3
	7.0	1.7	4.0	1050	41.6	2.15	34.3	106.7	5.68	5.1	1050	35.1	24.9	0.71	1.72	41.0	20.4	2.9
				1250	43.0	2.11	35.8	101.8	5.97	4.7	1250	36.2	27.8	0.77	1.80	42.3	20.2	3.1
9.0	2.9	6.8	1050	42.2	2.18	34.8	107.2	5.69	5.2	1050	35.5	24.9	0.70	1.68	41.2	21.1	2.7	
			1250	43.7	2.13	36.4	102.3	6.00	4.8	1250	36.6	27.9	0.76	1.76	42.6	20.7	3.0	
90	5.0	0.8	1.9	1050	43.3	2.18	35.9	108.2	5.82	5.5	1050	32.8	24.2	0.74	1.97	39.5	16.6	3.9
				1250	44.9	2.13	37.6	103.2	6.16	5.1	1250	33.8	27.0	0.80	2.05	40.8	16.5	4.1
	7.0	1.7	3.9	1050	45.0	2.22	37.4	109.6	5.95	5.7	1050	33.0	24.2	0.73	1.90	39.5	17.4	3.6
				1250	46.6	2.17	39.2	104.5	6.31	5.3	1250	34.0	27.0	0.79	1.97	40.7	17.3	3.9
9.0	2.8	6.6	1050	45.5	2.25	37.9	110.2	5.93	5.9	1050	33.3	24.3	0.73	1.85	39.6	17.9	3.4	
			1250	47.3	2.19	39.8	105.0	6.32	5.4	1250	34.3	27.1	0.79	1.94	40.9	17.7	3.7	
100	5.0	0.8	1.8	Operation not recommended							Operation not recommended							
	7.0	1.6	3.8	1050	32.1	24.0	0.75	2.12	39.3	15.1	4.5	Operation not recommended						
				1250	33.1	26.8	0.81	2.20	40.6	15.0	4.8	Operation not recommended						
	9.0	2.7	6.3	1050	32.4	24.1	0.75	2.08	39.4	15.6	4.1	Operation not recommended						
1250				33.4	26.9	0.81	2.15	40.7	15.5	4.6	Operation not recommended							
110	5.0	0.8	1.8	Operation not recommended							Operation not recommended							
	7.0	1.6	3.6	Operation not recommended							1050	28.9	22.3	0.77	2.35	36.9	12.3	5.4
				1250	29.8	24.9	0.84	2.42	38.0	12.3	5.9	Operation not recommended						
	9.0	2.6	6.1	Operation not recommended							1050	29.1	22.4	0.77	2.30	37.0	12.7	5.0
1250				30.1	25.0	0.83	2.37	38.2	12.7	5.6	Operation not recommended							
120	5.0	0.7	1.7	Operation not recommended							Operation not recommended							
	7.0	1.5	3.5	Operation not recommended							1050	27.1	22.0	0.81	2.63	36.1	10.3	6.5
				1250	27.9	24.5	0.88	2.70	37.1	10.4	7.1	Operation not recommended						
	9.0	2.5	5.8	Operation not recommended							1050	27.3	22.2	0.81	2.57	36.1	10.6	6.1
1250				28.2	24.6	0.87	2.63	37.2	10.7	6.7	Operation not recommended							

NB042 - Performance Data

Single Speed with Variable Speed ECM or 5-Speed ECM (1350 cfm)

EWT °F	Flow Rate gpm	Water Pressure Drop		HEATING - EAT 70°F							COOLING - EAT 80/67 °F							
		psi	ft/hd	Airflow cfm	HC MBtu/h	Power kW	HE MBtu/h	LAT °F	COP	HWC MBtu/h	Airflow cfm	TC MBtu/h	SC MBtu/h	S/T Ratio	Power kW	HR MBtu/h	EER	HWC MBtu/h
20	5.0	0.8	1.9	Operation not recommended							Operation not recommended							
	8.0	2.3	5.3	Operation not recommended							Operation not recommended							
	11.0	4.4	10.3	1150	24.0	2.12	16.8	89.3	3.32	4.1	Operation not recommended							
				1350	24.3	2.10	17.1	86.7	3.39	3.7	Operation not recommended							
30	5.0	0.8	1.8	Operation not recommended							Operation not recommended							
	8.0	2.2	5.1	1150	27.9	2.16	20.6	92.5	3.80	4.3	1150	40.2	24.5	0.61	1.34	44.8	29.9	---
				1350	28.3	2.14	21.0	89.4	3.87	3.9	1350	42.1	27.5	0.65	1.42	46.9	29.6	---
	11.0	4.3	10.0	1150	28.3	2.16	21.0	92.8	3.85	4.4	1150	40.6	24.5	0.60	1.31	45.0	31.1	---
				1350	28.7	2.14	21.4	89.7	3.93	4.0	1350	42.5	27.5	0.65	1.38	47.2	30.8	---
	40	5.0	0.8	1.8	Operation not recommended							Operation not recommended						
8.0		2.1	4.9	1150	31.8	2.24	24.1	95.6	4.15	4.7	1150	41.9	26.2	0.62	1.43	46.8	29.3	---
				1350	32.3	2.21	24.7	92.1	4.28	4.3	1350	43.8	29.4	0.67	1.51	48.9	29.0	---
11.0		4.2	9.7	1150	32.4	2.25	24.7	96.1	4.21	4.9	1150	42.3	26.2	0.62	1.39	47.1	30.5	---
				1350	32.9	2.21	25.3	92.5	4.35	4.4	1350	44.2	29.4	0.66	1.47	49.2	30.1	---
50		5.0	0.7	1.7	1150	34.2	2.26	26.5	97.5	4.44	5.1	1150	42.6	27.0	0.63	1.62	48.1	26.3
	1350				34.8	2.21	27.2	93.8	4.61	4.7	1350	44.4	30.4	0.68	1.71	50.2	26.0	2.6
	8.0	2.1	4.8	1150	35.6	2.31	27.7	98.7	4.52	5.3	1150	43.1	27.3	0.63	1.55	48.3	27.9	2.3
				1350	36.2	2.26	28.5	94.8	4.71	4.8	1350	44.8	30.7	0.68	1.63	50.4	27.6	2.5
	11.0	4.1	9.4	1150	36.3	2.32	28.4	99.3	4.58	5.4	1150	43.5	27.3	0.63	1.50	48.6	29.0	2.1
				1350	37.0	2.27	29.3	95.4	4.78	5.0	1350	45.3	30.7	0.68	1.58	50.7	28.7	2.4
60	5.0	0.7	1.7	1150	37.5	2.32	29.6	100.2	4.73	5.7	1150	42.5	27.7	0.65	1.78	48.5	23.8	3.0
				1350	38.3	2.26	30.5	96.2	4.96	5.3	1350	44.1	31.1	0.71	1.87	50.5	23.6	3.2
	8.0	2.0	4.6	1150	39.2	2.39	31.0	101.6	4.80	5.9	1150	43.0	28.0	0.65	1.70	48.8	25.4	2.8
				1350	40.0	2.32	32.1	97.4	5.06	5.4	1350	44.7	31.4	0.70	1.78	50.8	25.1	3.0
	11.0	3.9	9.1	1150	40.1	2.41	31.9	102.3	4.87	6.1	1150	43.4	28.0	0.64	1.65	49.1	26.4	2.6
				1350	41.0	2.34	33.0	98.1	5.14	5.6	1350	45.1	31.4	0.70	1.73	51.0	26.1	2.9
70	5.0	0.7	1.6	1150	40.7	2.40	32.5	102.8	4.97	6.4	1150	42.6	28.6	0.67	1.97	49.4	21.6	3.8
				1350	41.6	2.32	33.7	98.6	5.26	6.0	1350	44.2	32.1	0.73	2.06	51.2	21.4	4.0
	8.0	1.9	4.5	1150	42.7	2.48	34.2	104.4	5.04	6.6	1150	43.3	28.9	0.67	1.87	49.7	23.1	3.5
				1350	43.7	2.39	35.5	100.0	5.36	6.1	1350	44.9	32.5	0.72	1.96	51.5	22.9	3.8
	11.0	3.8	8.8	1150	43.8	2.51	35.2	105.2	5.11	6.8	1150	43.7	28.9	0.66	1.82	49.9	24.1	3.3
				1350	44.9	2.42	36.6	100.8	5.45	6.3	1350	45.3	32.5	0.72	1.90	51.8	23.8	3.6
80	5.0	0.7	1.6	1150	43.7	2.44	35.4	105.2	5.26	7.2	1150	41.0	27.9	0.68	2.19	48.5	18.7	4.8
				1350	44.9	2.34	36.9	100.8	5.63	6.7	1350	42.4	31.4	0.74	2.29	50.2	18.5	5.1
	8.0	1.9	4.3	1150	46.0	2.54	37.4	107.0	5.32	7.5	1150	41.8	28.2	0.68	2.08	48.9	20.1	4.5
				1350	47.3	2.42	39.0	102.4	5.72	6.9	1350	43.2	31.7	0.73	2.17	50.6	19.9	4.8
	11.0	3.7	8.5	1150	47.3	2.57	38.6	108.1	5.39	7.7	1150	42.2	28.2	0.67	2.02	49.1	20.9	4.1
				1350	48.7	2.46	40.3	103.4	5.82	7.1	1350	43.6	31.7	0.73	2.11	50.8	20.7	4.6
90	5.0	0.7	1.5	1150	46.7	2.48	38.2	107.6	5.51	8.1	1150	38.9	27.1	0.70	2.45	47.2	15.9	6.0
				1350	48.0	2.37	40.0	102.9	5.95	7.5	1350	40.1	30.5	0.76	2.55	48.8	15.7	6.4
	8.0	1.8	4.2	1150	49.2	2.60	40.4	109.6	5.55	8.4	1150	39.7	27.4	0.69	2.31	47.6	17.1	5.6
				1350	50.8	2.47	42.4	104.8	6.03	7.8	1350	40.9	30.8	0.75	2.41	49.1	17.0	6.1
	11.0	3.5	8.2	1150	50.8	2.64	41.8	110.9	5.63	8.6	1150	40.1	27.4	0.68	2.25	47.7	17.8	5.2
				1350	52.4	2.51	43.9	106.0	6.14	8.0	1350	41.3	30.8	0.75	2.34	49.3	17.6	5.8
100	5.0	0.6	1.5	Operation not recommended							Operation not recommended							
	8.0	1.7	4.0	1150	38.2	26.9	0.70	2.58	47.0	14.8	6.9	Operation not recommended						
				1350	39.2	30.2	0.77	2.68	48.4	14.6	7.5	Operation not recommended						
	11.0	3.4	7.9	1150	38.5	26.9	0.70	2.50	47.1	15.4	6.4	Operation not recommended						
1350				39.6	30.2	0.76	2.60	48.5	15.2	7.2	Operation not recommended							
110	5.0	0.6	1.4	Operation not recommended							Operation not recommended							
	8.0	1.7	3.9	Operation not recommended							1150	34.8	24.9	0.71	2.88	44.6	12.1	8.5
				1350	35.7	27.9	0.78	2.98	45.9	12.0	9.2	Operation not recommended						
	11.0	3.3	7.6	Operation not recommended							1150	35.1	24.9	0.71	2.79	44.7	12.6	7.9
1350				36.0	27.9	0.77	2.89	45.9	12.5	8.8	Operation not recommended							
120	5.0	0.6	1.3	Operation not recommended							Operation not recommended							
	8.0	1.6	3.7	Operation not recommended							1150	32.8	24.6	0.75	3.20	43.7	10.2	10.3
				1350	33.5	27.6	0.82	3.31	44.8	10.1	11.1	Operation not recommended						
	11.0	3.2	7.3	Operation not recommended							1150	33.1	24.6	0.74	3.11	43.7	10.7	9.5
1350				33.9	27.6	0.81	3.21	44.8	10.6	10.6	Operation not recommended							

NB048 - Performance Data

Single Speed with Variable Speed ECM or 5-Speed ECM (1500 cfm)

EWT °F	Flow Rate gpm	Water Pressure Drop		HEATING - EAT 70°F							COOLING - EAT 80/67 °F							
		psi	ft/hd	Airflow cfm	HC MBtu/h	Power kW	HE MBtu/h	LAT °F	COP	HWC MBtu/h	Airflow cfm	TC MBtu/h	SC MBtu/h	S/T Ratio	Power kW	HR MBtu/h	EER	HWC MBtu/h
20	6.0	1.1	2.6	Operation not recommended							Operation not recommended							
	9.0	2.3	5.4	Operation not recommended							Operation not recommended							
	12.0	4.0	9.2	1300	31.6	2.84	21.9	92.5	3.26	5.3	Operation not recommended							
				1500	32.0	2.82	22.4	89.7	3.33	4.8	Operation not recommended							
30	6.0	1.1	2.5	Operation not recommended							Operation not recommended							
	9.0	2.3	5.3	1300	36.3	2.92	26.3	95.8	3.64	5.6	1300	48.2	29.6	0.61	1.58	53.6	30.5	---
				1500	36.7	2.90	26.8	92.6	3.71	5.2	1500	50.5	33.3	0.66	1.67	56.2	30.2	---
	12.0	3.9	9.0	1300	36.8	2.93	26.8	96.2	3.68	5.8	1300	48.7	29.6	0.61	1.53	53.9	31.8	---
1500				37.2	2.90	27.3	93.0	3.76	5.3	1500	51.0	33.3	0.65	1.62	56.5	31.4	---	
40	6.0	1.1	2.5	Operation not recommended							Operation not recommended							
	9.0	2.2	5.1	1300	41.7	3.05	31.3	99.7	4.00	6.2	1300	50.1	31.2	0.62	1.74	56.0	28.9	---
				1500	42.2	3.00	32.0	96.1	4.13	5.7	1500	52.3	35.1	0.67	1.83	58.6	28.6	---
	12.0	3.8	8.7	1300	42.4	3.06	31.9	100.2	4.06	6.4	1300	50.6	31.2	0.62	1.68	56.4	30.0	---
1500				43.0	3.01	32.7	96.5	4.19	5.8	1500	52.9	35.1	0.66	1.78	58.9	29.7	---	
50	6.0	1.0	2.4	1300	44.7	3.09	34.1	101.8	4.24	6.7	1300	51.2	32.5	0.63	2.02	58.1	25.3	2.9
				1500	45.4	3.02	35.1	98.0	4.40	6.2	1500	53.3	36.5	0.68	2.13	60.6	25.1	3.1
	9.0	2.1	4.9	1300	46.5	3.16	35.7	103.1	4.32	6.9	1300	51.7	32.8	0.63	1.93	58.3	26.8	2.7
				1500	47.3	3.08	36.7	99.2	4.49	6.4	1500	53.9	36.8	0.68	2.03	60.8	26.6	2.9
12.0	3.7	8.4	1300	47.4	3.18	36.6	103.8	4.37	7.2	1300	52.2	32.8	0.63	1.87	58.6	27.9	2.5	
			1500	48.2	3.10	37.7	99.8	4.56	6.5	1500	54.4	36.8	0.68	1.97	61.1	27.6	2.8	
60	6.0	1.0	2.3	1300	49.1	3.18	38.2	105.0	4.52	7.6	1300	50.0	32.1	0.64	2.24	57.6	22.3	3.5
				1500	50.0	3.10	39.5	100.9	4.74	7.0	1500	51.9	36.0	0.69	2.35	59.9	22.1	3.7
	9.0	2.1	4.8	1300	51.3	3.28	40.1	106.5	4.59	7.8	1300	50.6	32.4	0.64	2.13	57.9	23.7	3.3
				1500	52.3	3.18	41.5	102.3	4.83	7.2	1500	52.6	36.4	0.69	2.24	60.2	23.5	3.6
12.0	3.5	8.2	1300	52.5	3.31	41.2	107.4	4.65	8.0	1300	51.1	32.4	0.63	2.07	58.2	24.7	3.0	
			1500	53.6	3.20	42.7	103.1	4.91	7.4	1500	53.1	36.4	0.69	2.17	60.5	24.4	3.4	
70	6.0	1.0	2.2	1300	53.6	3.29	42.4	108.2	4.78	8.5	1300	49.7	32.4	0.65	2.51	58.3	19.8	4.4
				1500	54.7	3.17	43.9	103.8	5.05	7.9	1500	51.5	36.5	0.71	2.63	60.5	19.6	4.7
	9.0	2.0	4.6	1300	56.1	3.40	44.5	110.0	4.84	8.8	1300	50.5	32.8	0.65	2.38	58.6	21.2	4.1
				1500	57.4	3.27	46.3	105.5	5.14	8.1	1500	52.3	36.8	0.70	2.50	60.9	21.0	4.5
12.0	3.4	7.9	1300	57.6	3.44	45.8	111.0	4.91	9.0	1300	51.0	32.8	0.64	2.31	58.9	22.0	3.8	
			1500	59.0	3.31	47.7	106.4	5.22	8.3	1500	52.9	36.8	0.70	2.42	61.1	21.8	4.2	
80	6.0	0.9	2.1	1300	57.1	3.37	45.6	110.7	4.97	9.6	1300	47.7	31.7	0.67	2.81	57.3	17.0	5.6
				1500	58.6	3.23	47.5	106.2	5.32	8.8	1500	49.3	35.6	0.72	2.94	59.3	16.8	5.9
	9.0	1.9	4.5	1300	60.1	3.50	48.1	112.8	5.03	9.8	1300	48.5	32.0	0.66	2.66	57.6	18.2	5.2
				1500	61.7	3.35	50.3	108.1	5.40	9.1	1500	50.2	36.0	0.72	2.78	59.7	18.0	5.6
12.0	3.3	7.6	1300	61.8	3.55	49.7	114.0	5.10	10.1	1300	49.0	32.0	0.65	2.59	57.8	19.0	4.8	
			1500	63.5	3.39	51.9	109.2	5.49	9.4	1500	50.7	36.0	0.71	2.70	59.9	18.8	5.4	
90	6.0	0.9	2.1	1300	60.7	3.45	48.9	113.2	5.16	10.7	1300	44.5	30.3	0.68	3.14	55.2	14.2	7.0
				1500	62.4	3.29	51.2	108.5	5.56	9.9	1500	45.9	34.0	0.74	3.27	57.0	14.0	7.4
	9.0	1.9	4.3	1300	64.1	3.61	51.7	115.6	5.20	11.1	1300	45.4	30.6	0.67	2.97	55.5	15.3	6.5
				1500	66.0	3.43	54.3	110.7	5.64	10.2	1500	46.8	34.3	0.73	3.09	57.4	15.1	7.1
12.0	3.2	7.4	1300	66.1	3.67	53.5	117.0	5.27	11.4	1300	45.9	30.6	0.67	2.88	55.7	15.9	6.1	
			1500	68.1	3.48	56.2	112.0	5.74	10.6	1500	47.3	34.3	0.73	3.00	57.5	15.7	6.7	
100	6.0	0.9	2.0	Operation not recommended							Operation not recommended							
	9.0	1.8	4.2	Operation not recommended							1300	43.9	30.1	0.69	3.33	55.2	13.2	8.1
				1500	45.1	33.9	0.75	3.46	56.9	13.0	8.8							
	12.0	3.1	7.1	Operation not recommended							1300	44.3	30.1	0.68	3.23	55.3	13.7	7.5
1500				45.6	33.9	0.74	3.36	57.0	13.6	8.4								
110	6.0	0.8	1.9	Operation not recommended							Operation not recommended							
	9.0	1.7	4.0	Operation not recommended							1300	39.7	28.0	0.71	3.71	52.3	10.7	9.9
				1500	40.7	31.4	0.77	3.84	53.8	10.6	10.8							
	12.0	3.0	6.8	Operation not recommended							1300	40.1	28.0	0.70	3.60	52.3	11.1	9.2
1500				41.1	31.4	0.77	3.73	53.8	11.0	10.2								
120	6.0	0.8	1.8	Operation not recommended							Operation not recommended							
	9.0	1.7	3.8	Operation not recommended							1300	37.6	27.4	0.73	4.13	51.7	9.1	12.0
				1500	38.4	30.8	0.80	4.27	53.0	9.0	13.0							
	12.0	2.8	6.6	Operation not recommended							1300	37.9	27.4	0.72	4.01	51.6	9.5	11.1
1500				38.8	30.8	0.79	4.15	53.0	9.4	12.4								

NB060 - Performance Data

Single Speed with Variable Speed ECM or 5-Speed ECM (2000 cfm)

EWT °F	Flow Rate gpm	Water Pressure Drop		HEATING - EAT 70°F							COOLING - EAT 80/67 °F							
		psi	ft/hd	Airflow cfm	HC MBtu/h	Power kW	HE MBtu/h	LAT °F	COP	HWC MBtu/h	Airflow cfm	TC MBtu/h	SC MBtu/h	S/T Ratio	Power kW	HR MBtu/h	EER	HWC MBtu/h
20	9.0	2.5	5.7	Operation not recommended														
	12.0	4.0	9.2	Operation not recommended														
	15.0	5.9	13.5	1500	38.6	3.70	26.0	93.8	3.06	6.5	Operation not recommended							
				2000	39.4	3.77	26.5	88.2	3.06	5.8	Operation not recommended							
30	9.0	2.4	5.5	Operation not recommended														
	12.0	3.9	8.9	1500	43.5	3.70	30.9	96.9	3.45	6.8	1500	73.6	46.9	0.64	2.16	81.0	34.1	---
				2000	44.4	3.77	31.5	90.5	3.45	6.2	2000	71.2	48.3	0.68	2.61	80.2	27.3	---
	15.0	5.7	13.1	1500	44.9	3.80	31.9	97.7	3.46	7.0	1500	74.3	47.0	0.63	2.16	81.7	34.4	---
2000				45.8	3.86	32.6	91.2	3.47	6.4	2000	72.4	47.8	0.66	2.44	80.8	29.6	---	
40	9.0	2.3	5.3	Operation not recommended														
	12.0	3.7	8.7	1500	51.3	3.86	38.2	101.7	3.90	7.5	1500	71.9	47.4	0.66	2.40	80.1	30.0	---
				2000	52.5	3.94	39.1	94.3	3.91	6.9	2000	71.3	49.5	0.69	2.81	80.9	25.4	---
	15.0	5.5	12.7	1500	52.8	3.94	39.3	102.6	3.92	7.8	1500	72.6	47.6	0.66	2.39	80.8	30.4	---
2000				53.8	4.01	40.1	94.9	3.93	7.1	2000	72.1	49.3	0.68	2.65	81.2	27.2	---	
50	9.0	2.2	5.2	1500	57.3	4.00	43.6	105.4	4.19	8.1	1500	72.2	48.4	0.67	2.81	81.8	25.7	3.9
				2000	57.9	4.05	44.1	96.8	4.19	7.5	2000	72.4	50.2	0.69	3.15	83.1	23.0	4.1
	12.0	3.6	8.4	1500	57.9	3.99	44.3	105.7	4.25	8.4	1500	72.3	48.5	0.67	2.71	81.6	26.7	3.6
				2000	59.4	4.09	45.5	97.5	4.26	7.7	2000	72.4	50.7	0.70	3.09	82.9	23.5	3.9
15.0	5.3	12.3	1500	59.4	4.08	45.5	106.6	4.27	8.6	1500	73.0	48.7	0.67	2.70	82.2	27.1	3.4	
			2000	60.5	4.13	46.4	98.0	4.29	7.9	2000	73.1	50.7	0.69	2.94	83.2	24.9	3.7	
60	9.0	2.2	5.0	1500	63.3	4.14	49.2	109.1	4.48	9.1	1500	68.5	46.2	0.68	3.04	78.9	22.5	4.7
				2000	64.4	4.17	50.1	99.8	4.52	8.4	2000	70.0	49.1	0.70	3.33	81.4	21.0	5.0
	12.0	3.5	8.1	1500	64.9	4.16	50.7	110.0	4.57	9.4	1500	68.7	46.4	0.68	2.93	78.7	23.4	4.4
				2000	65.8	4.21	51.4	100.5	4.57	8.7	2000	70.4	49.3	0.70	3.24	81.4	21.7	4.8
15.0	5.2	11.9	1500	66.3	4.23	51.9	110.9	4.59	9.7	1500	69.4	46.7	0.67	2.91	79.3	23.9	4.1	
			2000	67.7	4.28	53.1	101.3	4.63	8.9	2000	70.8	49.6	0.70	3.12	81.4	22.7	4.6	
70	9.0	2.1	4.9	1500	69.5	4.29	54.9	112.9	4.75	10.3	1500	65.9	45.2	0.69	3.42	77.5	19.3	5.9
				2000	71.0	4.31	56.3	102.9	4.83	9.5	2000	68.8	49.1	0.71	3.68	81.3	18.7	6.3
	12.0	3.4	7.9	1500	72.0	4.33	57.2	114.5	4.87	10.6	1500	66.2	45.5	0.69	3.29	77.4	20.1	5.5
				2000	72.4	4.35	57.5	103.5	4.87	9.8	2000	69.5	49.1	0.71	3.54	81.6	19.6	6.0
15.0	5.0	11.6	1500	73.4	4.40	58.4	115.3	4.89	10.9	1500	66.8	45.8	0.69	3.25	77.9	20.6	5.1	
			2000	75.1	4.44	59.9	104.7	4.95	10.0	2000	69.5	49.6	0.71	3.44	81.2	20.2	5.7	
80	9.0	2.0	4.7	1500	74.3	4.41	59.3	115.9	4.94	11.5	1500	64.1	44.6	0.70	3.81	77.0	16.8	7.5
				2000	75.7	4.41	60.6	105.0	5.03	10.7	2000	65.7	47.7	0.73	4.06	79.6	16.2	8.0
	12.0	3.3	7.6	1500	77.7	4.48	62.4	117.9	5.08	11.9	1500	64.4	45.0	0.70	3.66	76.9	17.6	7.0
				2000	78.3	4.44	63.2	106.3	5.18	11.0	2000	66.4	47.7	0.72	3.87	79.6	17.2	7.6
15.0	4.8	11.2	1500	78.9	4.54	63.4	118.7	5.10	12.2	1500	65.1	45.4	0.70	3.60	77.4	18.1	6.5	
			2000	80.5	4.57	64.9	107.3	5.16	11.3	2000	66.7	48.2	0.72	3.76	79.6	17.8	7.2	
90	9.0	2.0	4.5	1500	79.3	4.54	63.8	119.0	5.12	13.0	1500	60.9	43.2	0.71	4.20	75.2	14.5	9.4
				2000	80.6	4.53	65.1	107.3	5.21	12.0	2000	61.3	45.5	0.74	4.45	76.5	13.8	10.0
	12.0	3.2	7.3	1500	83.5	4.65	67.7	121.6	5.27	13.4	1500	61.3	43.7	0.71	4.03	75.1	15.2	8.8
				2000	84.5	4.53	69.1	109.1	5.47	12.4	2000	61.9	45.5	0.73	4.20	76.3	14.7	9.5
15.0	4.7	10.8	1500	84.7	4.69	68.6	122.3	5.29	13.8	1500	61.9	44.1	0.71	3.96	75.4	15.7	8.2	
			2000	86.2	4.72	70.0	109.9	5.35	12.8	2000	62.6	46.0	0.73	4.08	76.5	15.3	9.1	
100	9.0	1.9	4.4	Operation not recommended														
	12.0	3.1	7.1	1500	58.8	4.29	0.73	4.59	74.5	12.8	10.9	Operation not recommended						
				2000	59.4	4.47	0.75	4.70	75.5	12.6	11.8	Operation not recommended						
	15.0	4.5	10.4	1500	59.4	4.34	0.73	4.49	74.8	13.2	10.1	Operation not recommended						
2000				60.0	4.52	0.75	4.58	75.7	13.1	11.2	Operation not recommended							
110	9.0	1.8	4.2	Operation not recommended														
	12.0	2.9	6.8	1500	53.8	3.99	0.74	5.08	71.2	10.6	13.4	Operation not recommended						
				2000	54.4	4.15	0.76	5.14	71.9	10.6	14.5	Operation not recommended						
	15.0	4.3	10.0	1500	54.4	4.04	0.74	4.96	71.3	11.0	12.4	Operation not recommended						
2000				54.9	4.21	0.77	5.01	72.0	11.0	13.8	Operation not recommended							
120	9.0	1.7	4.0	Operation not recommended														
	12.0	2.8	6.5	1500	51.8	40.5	0.78	5.78	71.5	9.0	16.1	Operation not recommended						
				2000	50.8	41.2	0.81	5.80	70.6	8.8	17.5	Operation not recommended						
	15.0	4.2	9.6	1500	52.3	41.1	0.78	5.62	71.5	9.3	15.0	Operation not recommended						
2000				51.7	41.7	0.81	5.63	70.9	9.2	16.7	Operation not recommended							

NB070 - Performance Data

Single Speed with Variable Speed ECM or 5-Speed ECM (2200 cfm)

EWT °F	Flow Rate gpm	Water Pressure Drop		HEATING - EAT 70°F							COOLING - EAT 80/67 °F							
		psi	ft/hd	Airflow cfm	HC MBtu/h	Power kW	HE MBtu/h	LAT °F	COP	HWC MBtu/h	Airflow cfm	TC MBtu/h	SC MBtu/h	S/T Ratio	Power kW	HR MBtu/h	EER	HWC MBtu/h
20	12.0	3.0	7.0	Operation not recommended							Operation not recommended							
	15.0	4.4	10.2	Operation not recommended							Operation not recommended							
	18.0	6.0	13.9	1700	45.6	4.45	30.4	94.8	3.00	7.7	Operation not recommended							
				2200	46.6	4.54	31.2	89.6	3.01	6.9	Operation not recommended							
30	12.0	3.0	6.8	Operation not recommended							Operation not recommended							
	15.0	4.3	9.9	1700	52.5	4.55	37.0	98.6	3.38	8.1	1700	69.3	43.4	0.63	2.39	77.5	29.0	---
				2200	53.8	4.65	37.9	92.6	3.39	7.4	2200	73.9	49.6	0.67	2.79	83.4	26.5	---
	18.0	5.8	13.5	1700	52.7	4.57	37.1	98.7	3.38	8.4	1700	69.7	42.9	0.62	2.38	77.8	29.3	---
				2200	54.0	4.66	38.1	92.7	3.39	7.6	2200	74.3	49.0	0.66	2.78	83.8	26.7	---
	40	12.0	2.9	6.6	Operation not recommended							Operation not recommended						
15.0		4.1	9.6	1700	61.3	4.75	45.1	103.4	3.78	8.9	1700	71.7	46.1	0.64	2.63	80.6	27.3	---
				2200	62.8	4.80	46.4	96.4	3.83	8.2	2200	76.1	52.7	0.69	3.03	86.4	25.1	---
18.0		5.7	13.1	1700	61.7	4.77	45.4	103.6	3.79	9.2	1700	72.2	45.9	0.64	2.61	81.1	27.7	---
				2200	63.2	4.82	46.7	96.6	3.84	8.4	2200	76.6	52.5	0.68	3.01	86.9	25.5	---
50		12.0	2.8	6.4	1700	67.6	4.89	50.9	106.8	4.05	9.7	1700	75.1	48.4	0.64	3.01	85.4	24.9
	2200				69.2	4.91	52.4	99.1	4.13	8.9	2200	79.4	55.4	0.70	3.43	91.1	23.2	4.5
	15.0	4.0	9.3	1700	68.9	4.94	52.1	107.5	4.09	10.0	1700	75.5	48.7	0.64	2.92	85.5	25.8	4.0
				2200	70.6	4.95	53.7	99.7	4.18	9.2	2200	79.8	55.7	0.70	3.33	91.2	24.0	4.3
	18.0	5.5	12.7	1700	69.5	4.97	52.6	107.9	4.10	10.3	1700	76.3	48.9	0.64	2.89	86.1	26.4	3.7
				2200	71.3	4.98	54.3	100.0	4.20	9.4	2200	80.6	55.9	0.69	3.29	91.9	24.5	4.1
60	12.0	2.7	6.2	1700	74.9	5.09	57.5	110.8	4.31	10.8	1700	72.3	46.9	0.65	3.31	83.5	21.8	5.2
				2200	76.8	5.06	59.5	102.3	4.45	10.0	2200	76.1	53.6	0.70	3.72	88.8	20.4	5.5
	15.0	3.9	9.0	1700	77.1	5.16	59.5	112.0	4.38	11.2	1700	72.6	47.0	0.65	3.22	83.5	22.6	4.8
				2200	79.1	5.12	61.6	103.3	4.53	10.3	2200	76.4	53.8	0.70	3.62	88.8	21.1	5.2
	18.0	5.3	12.3	1700	78.0	5.20	60.2	112.5	4.39	11.5	1700	73.5	47.6	0.65	3.17	84.3	23.2	4.5
				2200	80.0	5.15	62.4	103.7	4.55	10.6	2200	77.4	54.5	0.70	3.57	89.5	21.7	5.0
70	12.0	2.6	6.0	1700	82.6	5.30	64.5	115.0	4.57	12.2	1700	72.0	47.5	0.66	3.69	84.6	19.5	6.5
				2200	84.8	5.22	66.9	105.7	4.76	11.3	2200	75.5	54.4	0.72	4.11	89.5	18.4	6.9
	15.0	3.8	8.7	1700	85.6	5.40	67.2	116.6	4.65	12.6	1700	72.3	47.6	0.66	3.59	84.5	20.2	6.1
				2200	87.9	5.30	69.8	107.0	4.86	11.6	2200	75.8	54.5	0.72	3.99	89.4	19.0	6.6
	18.0	5.1	11.9	1700	86.8	5.44	68.2	117.3	4.67	13.0	1700	73.4	48.7	0.66	3.53	85.4	20.8	5.6
				2200	89.1	5.34	70.9	107.5	4.89	11.9	2200	76.9	55.7	0.72	3.93	90.3	19.6	6.3
80	12.0	2.5	5.8	1700	88.2	5.50	69.4	118.0	4.70	13.7	1700	69.1	45.5	0.66	4.12	83.1	16.8	8.2
				2200	90.7	5.37	72.3	108.2	4.95	12.7	2200	72.1	52.1	0.72	4.53	87.6	15.9	8.7
	15.0	3.6	8.4	1700	92.2	5.62	73.0	120.2	4.81	14.1	1700	69.3	45.5	0.66	4.00	82.9	17.3	7.7
				2200	94.8	5.47	76.2	109.9	5.08	13.1	2200	72.4	52.1	0.72	4.40	87.4	16.4	8.3
	18.0	5.0	11.5	1700	93.6	5.68	74.3	121.0	4.83	14.6	1700	70.5	46.9	0.67	3.92	83.9	18.0	7.1
				2200	96.5	5.52	77.6	110.6	5.12	13.5	2200	73.6	53.7	0.73	4.31	88.3	17.1	7.9
90	12.0	2.4	5.6	1700	94.2	5.72	74.7	121.3	4.83	15.4	1700	63.4	42.2	0.67	4.57	79.0	13.9	10.3
				2200	97.0	5.53	78.1	110.8	5.14	14.3	2200	66.0	48.4	0.73	4.98	83.0	13.3	10.9
	15.0	3.5	8.1	1700	99.2	5.87	79.2	124.1	4.96	15.9	1700	63.6	42.1	0.66	4.45	78.8	14.3	9.6
				2200	102.2	5.66	82.9	113.0	5.29	14.7	2200	66.2	48.3	0.73	4.84	82.7	13.7	10.4
	18.0	4.8	11.1	1700	100.9	5.93	80.7	125.0	4.99	16.4	1700	64.9	43.8	0.68	4.35	79.7	14.9	8.9
				2200	104.2	5.71	84.8	113.9	5.35	15.2	2200	67.5	50.3	0.74	4.73	83.6	14.3	9.9
100	12.0	2.3	5.4	Operation not recommended							Operation not recommended							
	15.0	3.4	7.8	Operation not recommended							1700	61.7	41.6	0.67	5.01	78.9	12.3	12.0
				2200	64.0	47.7	0.75	5.39	82.4	11.9	13.0							
	18.0	4.6	10.7	Operation not recommended							1700	63.1	43.7	0.69	4.88	79.8	12.9	11.1
2200				65.4	50.1	0.77	5.24	83.3	12.5	12.3								
110	12.0	2.2	5.2	Operation not recommended							Operation not recommended							
	15.0	3.3	7.5	Operation not recommended							1700	54.8	37.0	0.67	5.58	73.8	9.8	14.6
				2200	56.5	42.4	0.75	5.94	76.8	9.5	15.9							
	18.0	4.4	10.2	Operation not recommended							1700	56.1	39.1	0.70	5.41	74.6	10.4	13.6
2200				57.9	44.9	0.78	5.76	77.6	10.0	15.1								
120	12.0	2.2	5.0	Operation not recommended							Operation not recommended							
	15.0	3.1	7.2	Operation not recommended							1700	52.0	37.4	0.72	6.27	73.4	8.3	17.7
				2200	53.4	43.0	0.80	6.60	76.0	8.1	19.2							
	18.0	4.3	9.8	Operation not recommended							1700	53.4	40.0	0.75	6.06	74.1	8.8	16.4
2200				54.9	45.9	0.84	6.38	76.7	8.6	18.2								

NB026 - Performance Data

Dual Capacity with Variable Speed ECM or 5-Speed ECM Low Speed (700 cfm)

EWT °F	Flow Rate gpm	Water Pressure Drop		HEATING - EAT 70°F							COOLING - EAT 80/67 °F							
		psi	ft/hd	Airflow cfm	HC MBtu/h	Power kW	HE MBtu/h	LAT °F	COP	HWC MBtu/h	Airflow cfm	TC MBtu/h	SC MBtu/h	S/T Ratio	Power kW	HR MBtu/h	EER	HWC MBtu/h
20	3.0	0.8	1.9	Operation not recommended							Operation not recommended							
	5.0	2.0	4.7	Operation not recommended							Operation not recommended							
	7.0	3.7	8.7	500	11.8	1.05	8.2	91.8	3.30	1.8	Operation not recommended							
				700	11.9	1.05	8.3	85.8	3.32	1.6	Operation not recommended							
30	3.0	0.8	1.8	Operation not recommended							Operation not recommended							
	5.0	2.0	4.5	500	13.5	1.06	9.9	95.1	3.75	1.8	500	22.5	14.1	0.63	0.52	24.3	43.2	---
				700	13.8	1.07	10.2	88.3	3.80	1.6	700	22.8	15.4	0.67	0.55	24.7	41.6	---
	7.0	3.6	8.4	500	13.8	1.07	10.2	95.6	3.80	1.8	500	22.6	14.1	0.62	0.51	24.3	44.7	---
700				14.0	1.08	10.3	88.5	3.81	1.6	700	23.2	15.4	0.67	0.53	25.0	43.6	---	
40	3.0	0.8	1.8	Operation not recommended							Operation not recommended							
	5.0	1.9	4.4	500	16.0	1.068	12.3	99.6	4.38	1.8	500	23.3	14.7	0.63	0.57	25.3	40.8	---
				700	16.3	1.07	12.6	91.5	4.45	1.7	700	23.8	16.0	0.67	0.60	25.8	39.6	---
	7.0	3.5	8.2	500	16.2	1.08	12.6	100.1	4.40	1.9	500	23.5	14.7	0.63	0.56	25.4	42.3	---
700				16.6	1.08	12.9	91.9	4.49	1.7	700	24.0	16.0	0.67	0.58	26.0	41.4	---	
50	3.0	0.7	1.7	500	17.3	1.06	13.6	102.0	4.75	1.9	500	23.8	15.1	0.63	0.68	26.1	35.2	0.7
				700	17.6	1.06	14.0	93.3	4.85	1.7	700	24.3	16.4	0.68	0.70	26.7	34.5	0.8
	5.0	1.8	4.3	500	18.1	1.09	14.4	103.6	4.89	1.9	500	24.0	15.2	0.63	0.64	26.2	37.4	0.7
				700	18.5	1.09	14.8	94.5	4.98	1.8	700	24.5	16.6	0.68	0.67	26.8	36.6	0.7
	7.0	3.4	7.9	500	18.4	1.10	14.6	104.1	4.89	2.0	500	24.3	15.2	0.63	0.62	26.4	39.0	0.6
				700	18.8	1.10	15.1	94.9	5.04	1.8	700	24.8	16.6	0.67	0.65	27.0	38.1	0.7
60	3.0	0.7	1.7	500	19.5	1.08	15.8	106.2	5.29	2.1	500	23.0	14.8	0.64	0.76	25.6	30.1	1.0
				700	20.0	1.07	16.3	96.4	5.46	1.9	700	23.5	16.1	0.69	0.79	26.2	29.6	1.0
	5.0	1.8	4.1	500	20.4	1.10	16.7	107.9	5.42	2.1	500	23.2	14.9	0.64	0.72	25.7	32.1	0.9
				700	21.0	1.10	17.2	97.7	5.60	2.0	700	23.7	16.3	0.69	0.75	26.3	31.5	1.0
	7.0	3.3	7.6	500	20.8	1.12	17.0	108.5	5.44	2.2	500	23.5	14.9	0.64	0.70	25.9	33.4	0.8
				700	21.3	1.10	17.5	98.2	5.65	2.0	700	23.9	16.3	0.68	0.73	26.4	32.8	0.9
70	3.0	0.7	1.6	500	21.9	1.10	18.2	110.6	5.86	2.3	500	23.0	15.0	0.65	0.87	26.0	26.4	1.3
				700	22.4	1.07	18.8	99.7	6.12	2.1	700	23.5	16.3	0.69	0.91	26.6	25.9	1.4
	5.0	1.7	4.0	500	22.9	1.12	19.0	112.3	6.00	2.4	500	23.2	15.1	0.65	0.82	26.0	28.2	1.3
				700	23.6	1.10	19.8	101.2	6.26	2.2	700	23.7	16.5	0.69	0.86	26.7	27.7	1.4
	7.0	3.2	7.4	500	23.3	1.13	19.4	113.1	6.03	2.4	500	23.5	15.1	0.64	0.80	26.2	29.2	1.2
				700	23.9	1.11	20.1	101.6	6.31	2.2	700	23.9	16.5	0.69	0.83	26.7	28.8	1.3
80	3.0	0.7	1.6	500	23.8	1.13	19.9	114.0	6.19	2.6	500	21.7	14.5	0.67	1.00	25.1	21.8	1.8
				700	24.5	1.10	20.7	102.4	6.54	2.4	700	22.2	15.7	0.71	1.03	25.7	21.5	1.9
	5.0	1.7	3.9	500	24.8	1.15	20.9	116.0	6.32	2.6	500	21.9	14.6	0.67	0.94	25.1	23.2	1.7
				700	25.6	1.12	21.8	103.9	6.70	2.4	700	22.4	15.9	0.71	0.98	25.7	22.9	1.9
	7.0	3.1	7.1	500	25.3	1.16	21.3	116.8	6.36	2.7	500	22.2	14.6	0.66	0.92	25.3	24.2	1.6
				700	26.1	1.13	22.2	104.5	6.75	2.5	700	22.6	15.9	0.70	0.95	25.8	23.8	1.8
90	3.0	0.7	1.5	500	25.8	1.15	21.9	117.8	6.56	2.9	500	19.8	13.6	0.69	1.14	23.7	17.4	2.4
				700	26.6	1.12	22.8	105.2	6.99	2.7	700	20.3	14.8	0.73	1.17	24.3	17.3	2.6
	5.0	1.6	3.7	500	26.9	1.18	22.9	119.8	6.69	3.0	500	20.0	13.8	0.69	1.08	23.7	18.5	2.3
				700	27.8	1.14	24.0	106.8	7.17	2.8	700	20.5	15.0	0.73	1.11	24.2	18.5	2.5
	7.0	3.0	6.9	500	27.3	1.19	23.3	120.6	6.71	3.1	500	20.3	13.8	0.68	1.04	23.8	19.4	2.1
				700	28.4	1.15	24.4	107.5	7.22	2.8	700	20.6	15.0	0.73	1.08	24.3	19.1	2.4
100	3.0	0.6	1.5	Operation not recommended							Operation not recommended							
	5.0	1.6	3.6	Operation not recommended							500	19.3	13.7	0.71	1.23	23.5	15.7	3.0
				700	19.7	14.8	0.75	1.27	24.1	15.6	3.2							
	7.0	2.9	6.6	Operation not recommended							500	19.5	13.7	0.70	1.19	23.6	16.4	2.8
700				19.9	14.8	0.75	1.23	24.1	16.1	3.1								
110	3.0	0.6	1.4	Operation not recommended							Operation not recommended							
	5.0	1.5	3.4	Operation not recommended							500	16.9	12.6	0.74	1.40	21.7	12.1	3.8
				700	17.3	13.7	0.79	1.44	22.2	12.0	4.1							
	7.0	2.8	6.4	Operation not recommended							500	17.1	12.6	0.74	1.36	21.8	12.6	3.5
700				17.5	13.7	0.78	1.40	22.2	12.5	3.9								
120	3.0	0.6	1.3	Operation not recommended							Operation not recommended							
	5.0	1.4	3.3	Operation not recommended							500	16.2	12.5	0.77	1.59	21.6	10.2	4.7
				700	16.5	13.5	0.82	1.63	22.1	10.1	5.1							
	7.0	2.7	6.1	Operation not recommended							500	16.3	12.5	0.76	1.54	21.6	10.6	4.3
700				16.7	13.5	0.81	1.59	22.1	10.5	4.8								

NB026 - Performance Data

Dual Capacity with Variable Speed ECM or 5-Speed ECM High Speed (900 cfm)

EWT °F	Flow Rate gpm	Water Pressure Drop		HEATING - EAT 70°F							COOLING - EAT 80/67 °F							
		psi	ft/hd	Airflow cfm	HC MBtu/h	Power kW	HE MBtu/h	LAT °F	COP	HWC MBtu/h	Airflow cfm	TC MBtu/h	SC MBtu/h	S/T Ratio	Power kW	HR MBtu/h	EER	HWC MBtu/h
20	4.0	1.4	3.2	Operation not recommended							Operation not recommended							
	6.0	2.9	6.6	Operation not recommended							Operation not recommended							
	8.0	4.8	11.1	700	16.2	1.40	11.4	91.5	3.40	2.1	Operation not recommended							
				900	16.4	1.41	11.6	86.9	3.41	1.9	Operation not recommended							
30	4.0	1.4	3.2	Operation not recommended							Operation not recommended							
	6.0	2.8	6.4	700	18.6	1.44	13.7	94.6	3.79	2.3	700	29.8	18.6	0.62	0.93	33.0	32.1	---
				900	19.0	1.45	14.0	89.5	3.83	2.1	900	30.3	20.3	0.67	0.98	33.6	31.0	---
	8.0	4.7	10.8	700	19.0	1.45	14.0	95.1	3.83	2.3	700	30.0	18.6	0.62	0.90	33.0	33.3	---
				900	19.2	1.46	14.3	89.8	3.85	2.1	900	30.7	20.3	0.66	0.95	33.9	32.5	---
40	4.0	1.3	3.1	Operation not recommended							Operation not recommended							
	6.0	2.7	6.2	700	21.6	1.50	16.5	98.6	4.24	2.5	700	30.2	19.1	0.63	1.01	33.7	29.9	---
				900	22.1	1.50	16.9	92.7	4.30	2.3	900	30.8	20.8	0.68	1.06	34.4	29.1	---
	8.0	4.5	10.4	700	22.0	1.51	16.8	99.1	4.26	2.6	700	30.5	19.1	0.63	0.98	33.8	31.1	---
				900	22.4	1.51	17.3	93.1	4.34	2.4	900	31.2	20.8	0.67	1.02	34.7	30.4	---
50	4.0	1.3	3.0	700	23.4	1.53	18.1	100.9	4.46	2.7	700	30.0	19.3	0.64	1.18	34.0	25.5	1.3
				900	23.8	1.53	18.6	94.5	4.55	2.5	900	30.7	21.0	0.69	1.22	34.8	25.1	1.4
	6.0	2.6	6.0	700	24.5	1.57	19.2	102.5	4.59	2.8	700	30.3	19.5	0.64	1.12	34.2	27.1	1.3
				900	25.0	1.57	19.7	95.7	4.67	2.6	900	31.0	21.3	0.69	1.16	34.9	26.6	1.4
	8.0	4.4	10.1	700	24.9	1.59	19.5	102.9	4.59	2.9	700	30.7	19.5	0.64	1.08	34.4	28.3	1.2
				900	25.5	1.58	20.1	96.2	4.73	2.7	900	31.3	21.3	0.68	1.13	35.1	27.7	1.3
60	4.0	1.2	2.9	700	26.3	1.62	20.8	104.8	4.77	3.1	700	29.7	19.2	0.65	1.28	34.0	23.2	1.6
				900	26.9	1.60	21.4	97.6	4.93	2.9	900	30.3	20.9	0.69	1.33	34.8	22.8	1.7
	6.0	2.5	5.8	700	27.5	1.65	21.9	106.4	4.89	3.2	700	30.0	19.4	0.65	1.21	34.1	24.7	1.5
				900	28.2	1.64	22.6	99.0	5.05	2.9	900	30.6	21.1	0.69	1.26	34.9	24.3	1.6
	8.0	4.2	9.8	700	28.0	1.67	22.3	107.0	4.91	3.3	700	30.3	19.4	0.64	1.18	34.3	25.7	1.4
				900	28.7	1.65	23.1	99.5	5.10	3.0	900	30.9	21.1	0.68	1.22	35.1	25.3	1.6
70	4.0	1.2	2.8	700	29.3	1.70	23.5	108.8	5.05	3.5	700	29.3	19.1	0.65	1.42	34.2	20.6	2.0
				900	30.0	1.67	24.3	100.9	5.28	3.2	900	29.9	20.8	0.69	1.48	34.9	20.2	2.1
	6.0	2.4	5.6	700	30.6	1.73	24.7	110.5	5.17	3.6	700	29.6	19.3	0.65	1.34	34.1	22.0	1.9
				900	31.5	1.71	25.7	102.5	5.40	3.3	900	30.2	21.0	0.69	1.40	35.0	21.6	2.0
	8.0	4.1	9.5	700	31.2	1.76	25.2	111.3	5.20	3.7	700	29.9	19.3	0.64	1.31	34.4	22.8	1.7
900				32.0	1.72	26.1	102.9	5.44	3.4	900	30.5	21.0	0.69	1.35	35.1	22.5	1.9	
80	4.0	1.2	2.7	700	32.0	1.80	25.8	112.3	5.20	3.9	700	28.2	18.8	0.67	1.57	33.5	17.9	2.5
				900	32.9	1.76	26.9	103.9	5.48	3.6	900	28.7	20.4	0.71	1.63	34.3	17.6	2.7
	6.0	2.4	5.4	700	33.4	1.84	27.1	114.2	5.31	4.0	700	28.4	18.9	0.67	1.49	33.5	19.0	2.3
				900	34.5	1.80	28.4	105.5	5.62	3.7	900	29.0	20.6	0.71	1.54	34.3	18.9	2.5
	8.0	4.0	9.2	700	34.0	1.87	27.6	114.9	5.33	4.1	700	28.7	18.9	0.66	1.45	33.7	19.9	2.2
				900	35.1	1.82	28.9	106.1	5.66	3.8	900	29.3	20.6	0.70	1.50	34.4	19.6	2.4
90	4.0	1.1	2.6	700	34.8	1.91	28.2	116.0	5.33	4.3	700	26.7	18.1	0.68	1.74	32.6	15.3	3.1
				900	35.9	1.86	29.6	107.0	5.67	4.0	900	27.3	19.7	0.72	1.79	33.4	15.2	3.3
	6.0	2.3	5.2	700	36.3	1.96	29.6	118.0	5.43	4.5	700	26.9	18.4	0.68	1.65	32.5	16.3	2.9
				900	37.6	1.89	31.1	108.6	5.82	4.1	900	27.5	19.9	0.72	1.69	33.3	16.3	3.2
	8.0	3.8	8.8	700	36.9	1.98	30.1	118.8	5.45	4.6	700	27.3	18.4	0.67	1.59	32.7	17.1	2.7
900				38.3	1.91	31.7	109.4	5.86	4.3	900	27.8	19.9	0.72	1.65	33.4	16.8	3.0	
100	4.0	1.1	2.5	Operation not recommended							Operation not recommended							
	6.0	2.2	5.1	Operation not recommended							700	25.6	17.8	0.70	1.85	31.9	13.8	3.6
				900	26.1	19.3	0.74	1.90	32.6	13.8	3.9							
	8.0	3.7	8.5	Operation not recommended							700	25.9	17.8	0.69	1.79	32.0	14.5	3.3
900				26.4	19.3	0.73	1.85	32.7	14.3	3.7								
110	4.0	1.0	2.4	Operation not recommended							Operation not recommended							
	6.0	2.1	4.9	Operation not recommended							700	23.4	16.8	0.72	2.04	30.4	11.5	4.4
				900	23.9	18.2	0.76	2.10	31.1	11.4	4.7							
	8.0	3.5	8.2	Operation not recommended							700	23.7	16.8	0.71	1.98	30.4	12.0	4.1
900				24.2	18.2	0.76	2.04	31.1	11.8	4.5								
120	4.0	1.0	2.3	Operation not recommended							Operation not recommended							
	6.0	2.0	4.7	Operation not recommended							700	21.7	16.1	0.74	2.29	29.5	9.5	5.3
				900	22.1	17.5	0.79	2.35	30.1	9.4	5.7							
	8.0	3.4	7.9	Operation not recommended							700	21.9	16.1	0.74	2.21	29.4	9.9	4.9
900				22.3	17.5	0.78	2.28	30.1	9.8	5.4								

NB038 - Performance Data

Dual Capacity with Variable Speed ECM or 5-Speed ECM Low Speed (1050 cfm)

EWT °F	Flow Rate gpm	Water Pressure Drop		HEATING - EAT 70°F							COOLING - EAT 80/67 °F							
		PSI	ft/hd	Airflow cfm	HC MBtu/h	Power kW	HE MBtu/h	LAT °F	COP	HWC MBtu/h	Airflow cfm	TC MBtu/h	SC MBtu/h	S/T Ratio	Power kW	HR MBtu/h	EER	HWC MBtu/h
20	4.0	0.9	2.1	Operation not recommended														
	6.0	1.7	4.0	Operation not recommended														
	8.0	2.9	6.7	900	15.1	1.40	10.3	85.5	3.17	2.5	Operation not recommended							
1050				15.7	1.43	10.8	83.9	3.22	2.3									
30	4.0	0.9	2.0	Operation not recommended							Operation not recommended							
	6.0	1.7	3.9	900	16.8	1.38	12.1	87.3	3.56	2.4	900	29.1	18.4	0.63	0.74	31.6	39.3	---
				1050	17.5	1.42	12.6	85.4	3.61	2.2	1050	29.9	20.4	0.68	0.75	32.5	39.6	---
	8.0	2.8	6.5	900	17.9	1.42	13.0	88.4	3.69	2.5	900	29.6	18.9	0.64	0.73	32.1	40.3	---
				1050	18.6	1.45	13.6	86.4	3.75	2.3	1050	30.4	20.9	0.69	0.75	33.0	40.6	---
40	4.0	0.8	1.9	Operation not recommended							Operation not recommended							
	6.0	1.6	3.8	900	19.8	1.41	15.0	90.4	4.13	2.5	900	30.3	19.7	0.65	0.80	33.0	37.8	---
				1050	20.5	1.44	15.6	88.1	4.19	2.3	1050	31.1	21.8	0.70	0.82	33.9	38.1	---
	8.0	2.7	6.3	900	20.9	1.44	16.0	91.5	4.24	2.6	900	30.8	20.2	0.66	0.79	33.5	38.8	---
				1050	21.6	1.47	16.6	89.1	4.31	2.4	1050	31.7	22.4	0.71	0.81	34.4	39.1	---
50	4.0	0.8	1.9	900	21.8	1.43	16.9	92.5	4.46	2.6	900	31.3	21.1	0.67	0.91	34.4	34.3	1.0
				1050	22.5	1.45	17.6	89.8	4.54	2.4	1050	32.2	23.4	0.73	0.93	35.3	34.6	1.1
	6.0	1.6	3.7	900	22.6	1.43	17.7	93.2	4.62	2.7	900	31.6	21.2	0.67	0.89	34.6	35.5	0.9
				1050	23.3	1.45	18.3	90.5	4.70	2.5	1050	32.5	23.5	0.72	0.91	35.6	35.8	1.0
	8.0	2.6	6.1	900	23.7	1.47	18.6	94.3	4.72	2.8	900	32.1	21.8	0.68	0.88	35.1	36.4	0.9
1050				24.4	1.49	19.3	91.5	4.81	2.5	1050	33.0	24.1	0.73	0.90	36.1	36.7	1.0	
60	4.0	0.8	1.8	900	24.6	1.46	19.6	95.3	4.94	2.9	900	30.1	20.3	0.68	1.02	33.5	29.5	1.3
				1050	25.2	1.47	20.2	92.2	5.02	2.6	1050	30.9	22.5	0.73	1.04	34.4	29.7	1.4
	6.0	1.5	3.6	900	25.6	1.46	20.6	96.3	5.15	3.0	900	30.3	20.5	0.67	0.99	33.7	30.5	1.3
				1050	26.2	1.47	21.2	93.1	5.24	2.7	1050	31.2	22.6	0.73	1.01	34.6	30.8	1.4
	8.0	2.5	5.9	900	26.5	1.49	21.4	97.3	5.21	3.0	900	30.8	21.0	0.68	0.98	34.2	31.3	1.2
1050				27.1	1.50	22.0	93.9	5.30	2.8	1050	31.7	23.2	0.73	1.00	35.1	31.6	1.3	
70	4.0	0.8	1.8	900	27.3	1.49	22.3	98.1	5.39	3.2	900	29.7	20.6	0.69	1.16	33.6	25.7	1.9
				1050	27.9	1.49	22.8	94.6	5.49	2.9	1050	30.5	22.8	0.75	1.18	34.5	25.9	2.0
	6.0	1.5	3.5	900	28.5	1.48	23.5	99.4	5.65	3.3	900	29.9	20.7	0.69	1.13	33.8	26.6	1.7
				1050	29.1	1.48	24.0	95.6	5.76	3.0	1050	30.8	23.0	0.75	1.15	34.7	26.8	1.9
	8.0	2.5	5.7	900	29.3	1.51	24.1	100.1	5.67	3.4	900	30.4	21.3	0.70	1.12	34.2	27.3	1.6
1050				29.8	1.51	24.6	96.3	5.78	3.1	1050	31.3	23.5	0.75	1.14	35.2	27.5	1.8	
80	4.0	0.7	1.7	900	29.9	1.51	24.8	100.8	5.79	3.6	900	28.6	20.2	0.71	1.32	33.1	21.7	2.5
				1050	30.3	1.51	25.2	96.7	5.91	3.3	1050	29.4	22.4	0.76	1.34	33.9	21.9	2.7
	6.0	1.4	3.3	900	31.4	1.50	26.2	102.3	6.11	3.7	900	28.8	20.3	0.71	1.28	33.2	22.5	2.4
				1050	31.7	1.49	26.6	98.0	6.23	3.4	1050	29.6	22.5	0.76	1.31	34.1	22.7	2.6
	8.0	2.4	5.5	900	31.8	1.54	26.6	102.7	6.07	3.8	900	29.3	20.8	0.71	1.27	33.6	23.0	2.2
1050				32.1	1.52	26.9	98.3	6.19	3.5	1050	30.1	23.1	0.77	1.30	34.5	23.2	2.5	
90	4.0	0.7	1.6	900	32.5	1.54	27.2	103.4	6.18	4.0	900	26.5	18.9	0.71	1.50	31.6	17.6	3.4
				1050	32.7	1.52	27.5	98.9	6.31	3.7	1050	27.2	20.9	0.77	1.53	32.4	17.8	3.6
	6.0	1.4	3.2	900	34.1	1.53	28.9	105.1	6.56	4.2	900	26.7	19.0	0.71	1.46	31.7	18.3	3.2
				1050	34.3	1.50	29.2	100.3	6.69	3.8	1050	27.4	21.0	0.77	1.49	32.5	18.4	3.4
	8.0	2.3	5.3	900	34.3	1.56	29.0	105.3	6.45	4.3	900	27.1	19.5	0.72	1.45	32.1	18.7	2.9
1050				34.4	1.53	29.2	100.4	6.59	4.0	1050	27.9	21.6	0.77	1.48	32.9	18.9	3.3	
100	4.0	0.7	1.6	Operation not recommended														
	6.0	1.3	3.1	900	25.8	1.93	0.75	1.67	31.5	15.4	4.1	Operation not recommended						
				1050	26.5	21.4	0.81	1.70	32.3	15.6	4.5							
	8.0	2.2	5.1	900	26.2	19.8	0.76	1.65	31.8	15.8	3.8	Operation not recommended						
1050				26.9	21.9	0.81	1.69	32.7	16.0	4.2								
110	4.0	0.7	1.5	Operation not recommended														
	6.0	1.3	3.0	900	23.1	18.1	0.79	1.90	29.6	12.2	5.2	Operation not recommended						
				1050	23.7	20.1	0.85	1.93	30.3	12.3	5.7							
	8.0	2.1	4.9	900	23.5	18.6	0.79	1.88	29.9	12.5	4.8	Operation not recommended						
1050				24.1	20.6	0.85	1.92	30.7	12.6	5.4								
120	4.0	0.6	1.5	Operation not recommended														
	6.0	1.2	2.9	900	21.9	18.0	0.82	2.15	29.2	10.2	6.5	Operation not recommended						
				1050	22.5	19.9	0.88	2.20	30.0	10.2	7.0							
	8.0	2.0	4.7	900	22.2	18.4	0.83	2.13	29.5	10.4	6.0	Operation not recommended						
1050				22.9	20.4	0.89	2.18	30.3	10.5	6.7								

NB038 - Performance Data

Dual Capacity with Variable Speed ECM or 5-Speed ECM High Speed (1250 cfm)

EWT °F	Flow Rate gpm	Water Pressure Drop		HEATING - EAT 70°F							COOLING - EAT 80/67 °F							
		psi	ft/hd	Airflow cfm	HC MBtu/h	Power kW	HE MBtu/h	LAT °F	COP	HWC MBtu/h	Airflow cfm	TC MBtu/h	SC MBtu/h	S/T Ratio	Power kW	HR MBtu/h	EER	HWC MBtu/h
20	5.0	1.3	3.0	Operation not recommended														
	7.0	2.3	5.2	Operation not recommended														
	9.0	3.5	8.1	1050	21.6	1.90	15.1	89.0	3.34	2.9	Operation not recommended							
				1250	22.3	1.95	15.6	86.5	3.34	2.6	Operation not recommended							
30	5.0	1.2	2.9	Operation not recommended														
	7.0	2.2	5.1	1050	24.9	1.93	18.3	91.9	3.77	3.1	1050	37.9	22.5	0.59	1.41	42.8	27.0	---
				1250	25.6	1.99	18.8	88.9	3.77	2.8	1250	40.1	25.1	0.63	1.49	45.2	26.9	---
	9.0	3.4	7.9	1050	25.3	1.95	18.6	92.3	3.80	3.2	1050	38.2	24.8	0.65	1.37	42.9	28.0	---
				1250	26.1	2.01	19.2	89.3	3.80	2.9	1250	40.5	27.5	0.68	1.46	45.5	27.8	---
40	5.0	1.2	2.8	Operation not recommended														
	7.0	2.1	4.9	1050	29.0	2.05	22.0	95.6	4.16	3.4	1050	39.4	24.1	0.61	1.55	44.7	25.4	---
				1250	29.9	2.09	22.8	92.2	4.19	3.1	1250	41.5	26.8	0.65	1.64	47.1	25.4	---
	9.0	3.3	7.6	1050	29.6	2.07	22.5	96.1	4.20	3.5	1050	39.7	26.1	0.66	1.51	44.9	26.3	---
				1250	30.5	2.11	23.3	92.6	4.24	3.2	1250	42.0	29.0	0.69	1.60	47.4	26.2	---
50	5.0	1.2	2.7	1050	31.4	2.10	24.3	97.7	4.39	3.7	1050	39.6	25.1	0.63	1.84	45.9	21.5	1.9
				1250	32.4	2.13	25.1	94.0	4.46	3.4	1250	41.7	27.9	0.67	1.94	48.3	21.5	2.0
	7.0	2.1	4.8	1050	32.6	2.15	25.3	98.7	4.45	3.8	1050	40.5	25.4	0.63	1.74	46.4	23.3	1.8
				1250	33.6	2.17	26.2	94.9	4.53	3.5	1250	42.6	28.2	0.66	1.82	48.8	23.4	1.9
	9.0	3.2	7.4	1050	33.3	2.17	25.9	99.4	4.51	3.9	1050	40.9	27.1	0.66	1.69	46.7	24.1	1.7
				1250	34.4	2.19	26.9	95.5	4.59	3.6	1250	43.1	30.1	0.70	1.78	49.1	24.2	1.8
60	5.0	1.1	2.6	1050	34.7	2.20	27.2	100.6	4.62	4.2	1050	39.2	25.7	0.66	1.96	45.9	20.0	2.3
				1250	35.8	2.22	28.2	96.5	4.73	3.8	1250	41.1	28.6	0.70	2.05	48.1	20.1	2.4
	7.0	2.0	4.6	1050	36.2	2.26	28.5	102.0	4.69	4.3	1050	40.2	26.0	0.65	1.87	46.5	21.5	2.2
				1250	37.4	2.28	29.6	97.7	4.81	4.0	1250	42.1	28.9	0.69	1.94	48.7	21.6	2.3
	9.0	3.1	7.2	1050	37.1	2.29	29.3	102.7	4.76	4.4	1050	40.5	27.4	0.68	1.82	46.8	22.3	2.0
				1250	38.3	2.30	30.5	98.4	4.89	4.1	1250	42.5	30.4	0.71	1.90	49.0	22.4	2.2
70	5.0	1.1	2.5	1050	38.0	2.32	30.1	103.5	4.80	4.7	1050	39.2	26.6	0.68	2.15	46.5	18.2	2.9
				1250	39.3	2.32	31.4	99.1	4.96	4.3	1250	40.9	29.6	0.72	2.24	48.5	18.3	3.0
	7.0	1.9	4.5	1050	39.9	2.40	31.8	105.2	4.88	4.8	1050	40.2	26.9	0.67	2.06	47.2	19.5	2.7
				1250	41.2	2.40	33.1	100.6	5.04	4.4	1250	41.9	29.8	0.71	2.13	49.2	19.6	2.9
	9.0	3.0	6.9	1050	41.0	2.43	32.7	106.1	4.95	5.0	1050	40.6	28.0	0.69	2.01	47.5	20.2	2.5
				1250	42.4	2.42	34.1	101.4	5.14	4.6	1250	42.4	31.0	0.73	2.09	49.6	20.3	2.8
80	5.0	1.1	2.5	1050	40.4	2.41	32.2	105.6	4.90	5.2	1050	37.8	26.2	0.69	2.34	45.8	16.1	3.6
				1250	41.8	2.40	33.7	101.0	5.12	4.8	1250	39.3	29.2	0.74	2.42	47.5	16.3	3.8
	7.0	1.9	4.3	1050	42.7	2.51	34.2	107.7	4.99	5.4	1050	38.8	26.6	0.68	2.26	46.6	17.2	3.3
				1250	44.2	2.49	35.7	102.7	5.21	5.0	1250	40.4	29.4	0.73	2.33	48.3	17.4	3.6
	9.0	2.9	6.7	1050	44.0	2.54	35.3	108.8	5.07	5.6	1050	39.3	27.2	0.69	2.21	46.8	17.7	3.1
				1250	45.5	2.51	36.9	103.7	5.32	5.1	1250	40.9	30.1	0.74	2.28	48.7	17.9	3.4
90	5.0	1.0	2.4	1050	42.9	2.52	34.3	107.8	4.98	5.9	1050	35.7	25.5	0.71	2.53	44.3	14.1	4.4
				1250	44.4	2.49	35.9	102.9	5.24	5.4	1250	37.0	28.4	0.77	2.59	45.8	14.3	4.7
	7.0	1.8	4.2	1050	45.6	2.64	36.6	110.2	5.06	6.0	1050	36.8	25.9	0.70	2.46	45.1	15.0	4.1
				1250	47.2	2.59	38.4	105.0	5.34	5.6	1250	38.1	28.7	0.75	2.52	46.7	15.1	4.5
	9.0	2.8	6.5	1050	47.0	2.68	37.9	111.5	5.15	6.2	1050	37.2	26.1	0.70	2.42	45.4	15.4	3.9
				1250	48.6	2.61	39.7	106.0	5.46	5.8	1250	38.6	28.9	0.75	2.47	47.0	15.6	4.3
100	5.0	1.0	2.3	Operation not recommended														
	7.0	1.7	4.0	1050	35.4	25.6	0.72	2.74	44.8	12.9	5.1	Operation not recommended						
				1250	36.6	28.4	0.78	2.78	46.1	13.1	5.5	Operation not recommended						
	9.0	2.7	6.2	1050	35.8	25.6	0.71	2.69	45.0	13.3	4.8	Operation not recommended						
1250				37.0	28.3	0.76	2.74	46.3	13.5	5.3	Operation not recommended							
110	5.0	1.0	2.2	Operation not recommended														
	7.0	1.7	3.9	1050	32.4	24.1	0.74	2.99	42.6	10.8	6.2	Operation not recommended						
				1250	33.3	26.7	0.80	3.01	43.6	11.0	6.8	Operation not recommended						
	9.0	2.6	6.0	1050	32.7	23.7	0.73	2.94	42.8	11.1	5.8	Operation not recommended						
1250				33.6	26.2	0.78	2.97	43.8	11.3	6.4	Operation not recommended							
120	5.0	0.9	2.1	Operation not recommended														
	7.0	1.6	3.7	1050	30.5	23.6	0.77	3.34	41.9	9.1	7.5	Operation not recommended						
				1250	31.2	26.2	0.84	3.34	42.6	9.3	8.1	Operation not recommended						
	9.0	2.5	5.8	1050	30.8	23.0	0.75	3.29	42.0	9.4	7.0	Operation not recommended						
1250				31.5	25.3	0.81	3.30	42.7	9.5	7.7	Operation not recommended							

NB049 - Performance Data

Dual Capacity with Variable Speed ECM or 5-Speed ECM Low Speed (1350 cfm)

EWT °F	Flow Rate gpm	Water Pressure Drop		HEATING - EAT 70°F							COOLING - EAT 80/67 °F							
		psi	ft/hd	Airflow cfm	HC MBtu/h	Power kW	HE MBtu/h	LAT °F	COP	HWC MBtu/h	Airflow cfm	TC MBtu/h	SC MBtu/h	S/T Ratio	Power kW	HR MBtu/h	EER	HWC MBtu/h
20	5.0	0.9	2.2	Operation not recommended														
	8.0	2.0	4.6	Operation not recommended														
	11.0	3.4	7.8	1150	22.1	2.23	14.4	87.8	2.90	4.2	Operation not recommended							
				1350	22.9	2.26	15.1	85.7	2.96	3.8								
30	5.0	0.9	2.1	Operation not recommended														
	8.0	1.9	4.4	1150	25.4	2.28	17.7	90.5	3.27	4.3	1150	37.5	20.0	0.53	1.13	41.4	33.3	---
				1350	26.2	2.29	18.4	88.0	3.35	3.9	1350	38.8	23.6	0.61	1.20	42.9	32.4	---
	11.0	3.3	7.6	1150	26.1	2.29	18.2	91.0	3.33	4.4	1150	37.6	19.9	0.53	1.05	41.2	35.7	---
1350				27.0	2.32	19.1	88.5	3.40	4.0	1350	38.6	23.5	0.61	1.12	42.4	34.5	---	
40	5.0	0.9	2.0	Operation not recommended														
	8.0	1.9	4.3	1150	29.2	2.36	21.1	93.5	3.63	4.5	1150	39.6	21.8	0.55	1.24	43.9	31.9	---
				1350	30.2	2.36	22.2	90.7	3.76	4.2	1350	40.9	25.7	0.63	1.31	45.4	31.3	---
	11.0	3.2	7.4	1150	30.1	2.37	22.0	94.3	3.72	4.7	1150	39.8	21.8	0.55	1.17	43.8	34.1	---
1350				31.2	2.39	23.0	91.4	3.82	4.2	1350	40.9	25.7	0.63	1.23	45.1	33.3	---	
50	5.0	0.9	2.0	1150	30.2	2.35	22.2	94.3	3.77	4.8	1150	40.4	23.3	0.58	1.60	45.9	25.2	1.6
				1350	31.2	2.35	23.2	91.4	3.89	4.4	1350	41.7	27.5	0.66	1.67	47.4	24.9	1.7
	8.0	1.8	4.2	1150	32.6	2.43	24.3	96.2	3.93	4.9	1150	41.3	23.4	0.57	1.39	46.0	29.8	1.5
				1350	33.8	2.44	25.5	92.2	4.06	5.1	1350	42.5	27.6	0.65	1.45	47.5	29.2	1.6
11.0	3.1	7.2	1150	33.8	2.44	25.5	97.2	4.06	5.1	1150	41.5	23.4	0.56	1.31	46.0	31.8	1.4	
			1350	34.9	2.44	26.6	94.0	4.19	4.6	1350	42.8	27.6	0.65	1.37	47.5	31.1	1.5	
60	5.0	0.8	1.9	1150	33.0	2.44	24.7	96.6	3.97	5.2	1150	40.2	23.3	0.58	1.73	46.1	23.3	2.3
				1350	34.2	2.43	25.9	93.5	4.14	4.8	1350	41.5	27.4	0.66	1.80	47.6	23.0	2.4
	8.0	1.8	4.0	1150	35.7	2.50	27.2	98.8	4.19	5.4	1150	40.9	23.5	0.57	1.53	46.1	26.7	2.1
				1350	37.1	2.47	28.7	95.5	4.40	5.0	1350	42.1	27.6	0.66	1.60	47.6	26.3	2.3
11.0	3.0	6.9	1150	37.3	2.52	28.7	100.0	4.33	5.5	1150	41.3	23.5	0.57	1.46	46.3	28.4	1.9	
			1350	38.6	2.49	30.1	96.5	4.54	5.1	1350	42.6	27.7	0.65	1.52	47.8	28.0	2.2	
70	5.0	0.8	1.8	1150	35.7	2.53	27.1	98.8	4.14	5.8	1150	40.4	24.5	0.61	1.90	46.9	21.3	3.2
				1350	37.1	2.50	28.6	95.5	4.36	5.4	1350	41.7	28.8	0.69	1.99	48.5	20.9	3.4
	8.0	1.7	3.9	1150	38.8	2.57	30.0	101.2	4.42	6.0	1150	40.8	24.7	0.61	1.72	46.7	23.7	3.0
				1350	40.3	2.53	31.7	97.6	4.67	5.5	1350	42.1	29.1	0.69	1.80	48.3	23.4	3.2
11.0	2.9	6.7	1150	40.5	2.60	31.7	102.6	4.57	6.1	1150	41.6	24.8	0.60	1.65	47.2	25.2	2.8	
			1350	42.1	2.54	33.4	98.8	4.85	5.7	1350	42.8	29.2	0.68	1.71	48.7	25.0	3.1	
80	5.0	0.8	1.8	1150	37.9	2.59	29.1	100.5	4.30	6.5	1150	39.2	23.4	0.60	2.07	46.2	18.9	4.4
				1350	39.4	2.54	30.7	97.0	4.54	6.0	1350	40.4	27.5	0.68	2.16	47.8	18.7	4.6
	8.0	1.6	3.8	1150	41.2	2.62	32.3	103.2	4.61	6.7	1150	39.4	23.7	0.60	1.93	45.9	20.4	4.1
				1350	42.9	2.55	34.2	99.4	4.92	6.1	1350	40.5	27.9	0.69	2.00	47.4	20.2	4.4
11.0	2.8	6.5	1150	43.3	2.65	34.3	104.9	4.80	6.9	1150	40.2	23.9	0.59	1.84	46.5	21.8	3.8	
			1350	45.0	2.57	36.2	100.9	5.13	6.3	1350	41.5	28.1	0.68	1.92	48.0	21.6	4.2	
90	5.0	0.7	1.7	1150	40.0	2.64	31.0	102.2	4.43	7.2	1150	36.9	21.6	0.58	2.27	44.7	16.3	5.9
				1350	41.6	2.59	32.7	98.5	4.71	6.7	1350	38.1	25.4	0.67	2.36	46.2	16.1	6.2
	8.0	1.6	3.6	1150	43.5	2.66	34.4	105.0	4.79	7.4	1150	36.9	21.8	0.59	2.15	44.3	17.2	5.5
				1350	45.3	2.57	36.5	101.1	5.16	6.9	1350	38.0	25.7	0.68	2.23	45.6	17.0	5.9
11.0	2.7	6.2	1150	45.9	2.69	36.7	107.0	5.00	7.7	1150	38.0	22.1	0.58	2.06	45.0	18.4	5.1	
			1350	47.8	2.60	38.9	102.8	5.39	7.1	1350	39.1	26.0	0.66	2.15	46.5	18.2	5.6	
100	5.0	0.7	1.7	Operation not recommended														
	8.0	1.5	3.5	Operation not recommended														
				1150	35.2	22.5	0.64	2.42	43.5	14.6	7.1	Operation not recommended						
	1350	36.3	26.5	0.73	2.51	44.9	14.4	7.7										
11.0	2.6	6.0	1150	36.5	22.8	0.63	2.33	44.5	15.7	6.6	Operation not recommended							
			1350	37.6	26.8	0.71	2.43	45.9	15.5	7.3								
110	5.0	0.7	1.6	Operation not recommended														
	8.0	1.5	3.4	Operation not recommended														
				1150	31.6	21.2	0.67	2.69	40.8	11.7	9.0	Operation not recommended						
	1350	32.6	24.9	0.76	2.80	42.2	11.6	9.8										
11.0	2.5	5.8	1150	33.1	21.6	0.65	2.61	42.0	12.7	8.4	Operation not recommended							
			1350	34.0	25.3	0.74	2.72	43.3	12.5	9.3								
120	5.0	0.7	1.5	Operation not recommended														
	8.0	1.4	3.3	Operation not recommended														
				1150	29.1	20.6	0.71	3.01	39.4	9.7	11.2	Operation not recommended						
	1350	30.1	24.2	0.80	3.14	40.8	9.6	12.1										
11.0	2.4	5.6	1150	30.8	21.0	0.68	2.92	40.8	10.6	10.4	Operation not recommended							
			1350	31.6	24.7	0.78	3.06	42.0	10.3	11.5								

NB064 - Performance Data

Dual Capacity with Variable Speed ECM or 5-Speed ECM Low Speed (1500 cfm)

EWT °F	Flow Rate gpm	Water Pressure Drop		HEATING - EAT 70°F							COOLING - EAT 80/67 °F							
		psi	ft/hd	Airflow cfm	HC MBtu/h	Power kW	HE MBtu/h	LAT °F	COP	HWC MBtu/h	Airflow cfm	TC MBtu/h	SC MBtu/h	S/T Ratio	Power kW	HR MBtu/h	EER	HWC MBtu/h
20	6.0	1.0	2.4	Operation not recommended							Operation not recommended							
	10.0	2.7	6.2	Operation not recommended							Operation not recommended							
	14.0	5.1	11.8	1250	26.5	2.53	17.8	89.6	3.07	4.9	Operation not recommended							
				1500	27.4	2.56	18.6	86.9	3.13	4.5	Operation not recommended							
30	6.0	1.0	2.3	Operation not recommended							Operation not recommended							
	10.0	2.6	6.0	1250	30.7	2.60	21.8	92.8	3.46	5.0	1250	50.1	28.9	0.58	1.36	54.8	36.8	---
				1500	31.8	2.64	22.8	89.6	3.53	4.6	1500	51.6	32.9	0.64	1.42	56.5	36.2	---
	14.0	5.0	11.5	1250	31.8	2.60	22.9	93.6	3.58	5.1	1250	50.2	28.8	0.57	1.33	54.8	37.8	---
1500				32.9	2.64	23.9	90.3	3.66	4.7	1500	51.5	32.8	0.64	1.40	56.3	36.7	---	
40	6.0	1.0	2.3	Operation not recommended							Operation not recommended							
	10.0	2.5	5.9	1250	36.3	2.70	27.1	96.9	3.94	5.3	1250	51.6	29.6	0.57	1.50	56.7	34.5	---
				1500	37.3	2.70	28.0	93.0	4.04	4.9	1500	53.1	33.7	0.63	1.57	58.5	33.9	---
	14.0	4.8	11.1	1250	37.4	2.70	28.2	97.7	4.06	5.5	1250	51.7	29.5	0.57	1.46	56.7	35.4	---
1500				38.4	2.71	29.2	93.7	4.15	5.0	1500	53.1	33.6	0.63	1.54	58.4	34.5	---	
50	6.0	0.9	2.2	1250	40.8	2.74	31.5	100.2	4.37	5.6	1250	52.8	30.0	0.57	1.73	58.7	30.5	2.0
				1500	41.9	2.74	32.6	95.9	4.49	5.2	1500	54.4	34.1	0.63	1.83	60.6	29.7	2.1
	10.0	2.5	5.7	1250	41.4	2.79	31.9	100.7	4.36	5.7	1250	53.0	30.3	0.57	1.67	58.7	31.7	1.9
				1500	42.4	2.77	32.9	96.2	4.48	5.3	1500	54.5	34.3	0.63	1.75	60.5	31.1	2.0
	14.0	4.7	10.8	1250	42.7	2.80	33.1	101.6	4.46	5.9	1250	53.1	30.3	0.57	1.64	58.7	32.4	1.7
				1500	43.6	2.79	34.1	96.9	4.59	5.4	1500	54.6	34.3	0.63	1.72	60.5	31.8	1.9
60	6.0	0.9	2.1	1250	45.4	2.83	35.8	103.6	4.71	6.1	1250	50.9	29.4	0.58	1.94	57.5	26.3	2.8
				1500	46.4	2.80	36.8	98.6	4.85	5.7	1500	52.5	33.1	0.63	2.03	59.4	25.9	3.0
	10.0	2.4	5.5	1250	46.8	2.88	37.0	104.7	4.77	6.3	1250	51.1	29.6	0.58	1.87	57.5	27.3	2.6
				1500	47.6	2.84	37.9	99.4	4.92	5.8	1500	52.7	33.5	0.64	1.96	59.4	26.9	2.9
	14.0	4.5	10.4	1250	47.9	2.90	38.0	105.5	4.84	6.5	1250	51.4	29.7	0.58	1.84	57.6	28.0	2.5
				1500	48.7	2.86	38.9	100.1	4.99	6.0	1500	52.9	33.5	0.63	1.92	59.4	27.5	2.7
70	6.0	0.9	2.0	1250	49.9	2.92	39.9	107.0	5.01	6.8	1250	50.0	29.7	0.59	2.19	57.5	22.9	4.0
				1500	50.7	2.87	41.0	101.3	5.19	6.3	1500	51.6	33.3	0.65	2.28	59.4	22.6	4.2
	10.0	2.3	5.3	1250	52.0	2.97	41.9	108.5	5.14	7.0	1250	50.4	30.0	0.59	2.13	57.6	23.7	3.7
				1500	52.6	2.90	42.7	102.5	5.31	6.5	1500	51.9	33.7	0.65	2.22	59.5	23.4	4.0
	14.0	4.4	10.1	1250	53.0	3.00	42.8	109.3	5.18	7.2	1250	50.7	30.1	0.59	2.08	57.8	24.4	3.5
				1500	53.6	2.93	43.6	103.1	5.35	6.6	1500	52.2	33.8	0.65	2.17	59.6	24.0	3.9
80	6.0	0.9	2.0	1250	54.1	3.01	43.9	110.1	5.27	7.6	1250	47.9	28.7	0.60	2.47	56.3	19.4	5.5
				1500	54.6	2.94	44.6	103.7	5.44	7.0	1500	49.3	32.0	0.65	2.56	58.0	19.3	5.9
	10.0	2.2	5.1	1250	57.2	3.06	46.7	112.3	5.48	7.8	1250	48.3	28.9	0.60	2.41	56.5	20.0	5.2
				1500	57.4	2.97	47.3	105.5	5.68	7.2	1500	49.7	32.4	0.65	2.50	58.3	19.9	5.6
	14.0	4.2	9.8	1250	57.8	3.10	47.3	112.9	5.47	8.0	1250	48.6	29.1	0.60	2.37	56.7	20.5	4.8
				1500	58.1	3.01	47.8	105.8	5.66	7.4	1500	50.1	32.6	0.65	2.46	58.5	20.4	5.3
90	6.0	0.8	1.9	1250	58.2	3.10	47.6	113.1	5.51	8.5	1250	44.3	27.2	0.61	2.79	53.9	15.9	7.4
				1500	58.3	3.01	48.0	106.0	5.67	7.8	1500	45.7	30.2	0.66	2.87	55.5	15.9	7.8
	10.0	2.1	5.0	1250	62.1	3.14	51.4	116.0	5.79	8.7	1250	44.8	27.5	0.61	2.73	54.1	16.4	6.9
				1500	62.1	3.03	51.8	108.3	6.01	8.1	1500	46.1	30.6	0.66	2.82	55.8	16.3	7.5
	14.0	4.1	9.4	1250	62.5	3.19	51.6	116.3	5.74	9.0	1250	45.2	27.7	0.61	2.70	54.4	16.7	6.4
				1500	62.4	3.08	51.9	108.5	5.94	8.3	1500	46.6	30.9	0.66	2.78	56.1	16.8	7.1
100	6.0	0.8	1.8	Operation not recommended							Operation not recommended							
	10.0	2.1	4.8	Operation not recommended							1250	43.0	27.5	0.64	3.12	53.6	13.8	9.0
				1500	44.3	30.5	0.69	3.20	55.2	13.8	9.7							
	14.0	3.9	9.1	1250	43.4	27.9	0.64	3.07	53.9	14.1	8.3							
1500				44.8	30.8	0.69	3.15	55.5	14.2	9.2								
110	6.0	0.8	1.8	Operation not recommended							Operation not recommended							
	10.0	2.0	4.6	Operation not recommended							1250	38.7	26.0	0.67	3.53	50.7	10.9	11.3
				1500	39.9	28.6	0.72	3.60	52.2	11.1	12.3							
	14.0	3.8	8.7	1250	39.2	26.4	0.67	3.48	51.1	11.3	10.5							
1500				40.4	29.0	0.72	3.55	52.5	11.4	11.7								
120	6.0	0.7	1.7	Operation not recommended							Operation not recommended							
	10.0	1.9	4.4	Operation not recommended							1250	36.2	26.1	0.72	4.01	49.8	9.0	14.0
				1500	37.3	28.5	0.76	4.05	51.1	9.2	15.2							
	14.0	3.6	8.4	1250	36.7	26.6	0.72	3.96	50.2	9.3	13.0							
1500				37.8	29.0	0.77	4.00	51.5	9.5	14.5								

NB064 - Performance Data

Dual Capacity with Variable Speed ECM or 5-Speed ECM High Speed (1800 cfm)

EWT °F	Flow Rate gpm	Water Pressure Drop		HEATING - EAT 70°F							COOLING - EAT 80/67 °F							
		psi	ft/hd	Airflow cfm	HC MBtu/h	Power kW	HE MBtu/h	LAT °F	COP	HWC MBtu/h	Airflow cfm	TC MBtu/h	SC MBtu/h	S/T Ratio	Power kW	HR MBtu/h	EER	HWC MBtu/h
20	8.0	1.8	4.2	Operation not recommended							Operation not recommended							
	12.0	3.8	8.8	Operation not recommended							Operation not recommended							
	16.0	6.5	15.1	1500	39.7	3.44	28.0	94.5	3.38	6.2	Operation not recommended							
				1800	40.7	3.60	28.4	90.9	3.31	5.6	Operation not recommended							
30	8.0	1.8	4.1	Operation not recommended							Operation not recommended							
	12.0	3.7	8.6	1500	45.8	3.46	34.0	98.3	3.88	6.5	1500	65.1	40.8	0.63	2.23	72.7	29.1	---
				1800	47.1	3.68	34.5	94.2	3.75	6.0	1800	65.7	44.4	0.68	2.37	73.7	27.7	---
	16.0	6.4	14.7	1500	46.4	3.55	34.3	98.7	3.84	6.7	1500	65.7	41.2	0.63	2.19	73.2	30.0	---
1800				47.6	3.71	34.9	94.5	3.76	6.1	1800	66.2	44.8	0.68	2.33	74.1	28.4	---	
40	8.0	1.7	4.0	Operation not recommended							Operation not recommended							
	12.0	3.6	8.3	1500	52.7	3.69	40.1	102.5	4.19	7.2	1500	67.6	41.9	0.62	2.56	76.4	26.4	---
				1800	53.9	3.84	40.8	97.7	4.11	6.6	1800	68.6	45.6	0.66	2.72	77.9	25.2	---
	16.0	6.2	14.2	1500	53.5	3.75	40.7	103.0	4.18	7.4	1500	68.3	42.3	0.62	2.52	76.9	27.1	---
1800				54.7	3.88	41.5	98.2	4.13	6.7	1800	69.2	46.0	0.66	2.68	78.4	25.9	---	
50	8.0	1.7	3.8	1500	56.2	3.84	43.1	104.7	4.29	7.8	1500	68.7	42.2	0.61	3.00	78.9	22.9	4.0
				1800	57.4	3.96	43.9	99.5	4.25	7.2	1800	70.1	45.9	0.65	3.19	81.0	22.0	4.2
	12.0	3.5	8.1	1500	59.5	3.91	46.1	106.7	4.45	8.0	1500	69.4	42.6	0.61	2.94	79.4	23.6	3.7
				1800	60.7	4.01	47.0	101.2	4.43	7.4	1800	70.8	46.4	0.65	3.12	81.5	22.7	4.0
16.0	6.0	13.8	1500	60.4	3.96	46.9	107.3	4.48	8.2	1500	70.1	43.1	0.61	2.89	80.0	24.3	3.4	
			1800	61.8	4.05	47.9	101.8	4.47	7.5	1800	71.5	46.8	0.65	3.07	82.0	23.3	3.8	
60	8.0	1.6	3.7	1500	63.1	4.10	49.1	108.9	4.51	8.7	1500	67.1	41.8	0.62	3.23	78.2	20.8	4.8
				1800	64.4	4.17	50.2	103.1	4.53	8.0	1800	68.8	45.5	0.66	3.44	80.6	20.0	5.1
	12.0	3.4	7.8	1500	65.9	4.17	51.7	110.7	4.64	9.0	1500	67.8	42.2	0.62	3.17	78.6	21.4	4.5
				1800	67.4	4.22	53.0	104.7	4.68	8.3	1800	69.6	45.9	0.66	3.37	81.1	20.7	4.9
16.0	5.8	13.4	1500	67.4	4.22	53.0	111.6	4.68	9.2	1500	68.5	42.7	0.62	3.12	79.1	22.0	4.2	
			1800	68.9	4.26	54.3	105.4	4.74	8.5	1800	70.2	46.4	0.66	3.31	81.5	21.2	4.6	
70	8.0	1.6	3.6	1500	70.0	4.39	55.0	113.2	4.67	9.8	1500	67.7	42.2	0.62	3.60	80.0	18.8	6.1
				1800	71.5	4.41	56.4	106.8	4.75	9.0	1800	69.8	45.9	0.66	3.83	82.9	18.2	6.4
	12.0	3.3	7.5	1500	72.5	4.46	57.3	114.8	4.77	10.1	1500	68.4	42.6	0.62	3.53	80.4	19.4	5.7
				1800	74.2	4.47	58.9	108.2	4.87	9.3	1800	70.6	46.3	0.66	3.75	83.4	18.8	6.1
16.0	5.6	12.9	1500	74.4	4.51	59.0	115.9	4.84	10.4	1500	69.0	43.0	0.62	3.46	80.9	19.9	5.3	
			1800	76.1	4.51	60.7	109.2	4.95	9.6	1800	71.2	46.8	0.66	3.69	83.8	19.3	5.8	
80	8.0	1.5	3.5	1500	76.9	4.68	60.9	117.4	4.82	11.0	1500	63.8	40.8	0.64	3.90	77.1	16.3	7.7
				1800	78.6	4.65	62.8	110.5	4.95	10.2	1800	66.1	44.3	0.67	4.16	80.3	15.9	8.1
	12.0	3.2	7.3	1500	78.7	4.74	62.5	118.6	4.87	11.3	1500	64.4	41.1	0.64	3.83	77.5	16.8	7.1
				1800	80.6	4.69	64.6	111.4	5.04	10.5	1800	66.8	44.7	0.67	4.07	80.7	16.4	7.7
16.0	5.4	12.5	1500	81.1	4.79	64.7	120.0	4.96	11.7	1500	65.1	41.6	0.64	3.76	77.9	17.3	6.6	
			1800	83.1	4.74	66.9	112.7	5.14	10.8	1800	67.5	45.2	0.67	4.00	81.1	16.9	7.4	
90	8.0	1.4	3.3	1500	83.8	5.00	66.8	121.7	4.92	12.4	1500	58.7	39.3	0.67	4.18	72.9	14.0	9.6
				1800	85.8	4.92	69.0	114.2	5.11	11.4	1800	61.3	42.7	0.70	4.45	76.5	13.8	10.2
	12.0	3.0	7.0	1500	84.9	5.05	67.7	122.4	4.93	12.7	1500	59.3	39.6	0.67	4.10	73.3	14.5	9.0
				1800	87.1	4.95	70.2	114.8	5.16	11.8	1800	61.8	43.1	0.70	4.36	76.7	14.2	9.7
16.0	5.2	12.0	1500	87.9	5.12	70.4	124.2	5.03	13.1	1500	59.9	40.1	0.67	4.03	73.7	14.9	8.3	
			1800	90.2	5.00	73.1	116.4	5.29	12.2	1800	62.5	43.5	0.70	4.29	77.2	14.6	9.2	
100	8.0	1.4	3.2	Operation not recommended							Operation not recommended							
	12.0	2.9	6.8	Operation not recommended							1500	57.7	38.6	0.67	4.53	73.1	12.7	11.1
				1800	60.4	42.0	0.70	4.83	76.9	12.5	12.1							
	16.0	5.0	11.6	Operation not recommended							1500	58.2	39.1	0.67	4.45	73.4	13.1	10.3
1800				61.0	42.4	0.70	4.75	77.2	12.9	11.5								
110	8.0	1.3	3.1	Operation not recommended							Operation not recommended							
	12.0	2.8	6.5	Operation not recommended							1500	51.0	35.3	0.69	4.84	67.5	10.5	13.6
				1800	53.7	38.3	0.71	5.17	71.4	10.4	14.8							
	16.0	4.8	11.2	Operation not recommended							1500	51.5	35.7	0.69	4.76	67.7	10.8	12.7
1800				54.2	38.8	0.72	5.08	71.5	10.7	14.1								
120	8.0	1.3	3.0	Operation not recommended							Operation not recommended							
	12.0	2.7	6.3	Operation not recommended							1500	49.6	35.9	0.72	5.34	67.9	9.3	16.5
				1800	52.5	39.0	0.74	5.70	72.0	9.2	17.9							
	16.0	4.6	10.7	Operation not recommended							1500	50.1	36.3	0.73	5.25	68.0	9.5	15.3
1800				53.0	39.5	0.75	5.61	72.1	9.4	17.0								

NB072 - Performance Data

Dual Capacity with Variable Speed ECM or 5-Speed ECM Low Speed (1700 cfm)

EWT °F	Flow Rate gpm	Water Pressure Drop		HEATING - EAT 70°F							COOLING - EAT 80/67 °F							
		psi	ft/hd	Airflow cfm	HC MBtu/h	Power kW	HE MBtu/h	LAT °F	COP	HWC MBtu/h	Airflow cfm	TC MBtu/h	SC MBtu/h	S/T Ratio	Power kW	HR MBtu/h	EER	HWC MBtu/h
20	10.0	2.3	5.4	Operation not recommended							Operation not recommended							
	13.0	3.6	8.2	Operation not recommended							Operation not recommended							
	16.0	5.0	11.6	1400	31.8	3.36	20.3	91.0	2.77	6.0	Operation not recommended							
				1700	33.3	3.40	21.7	88.1	2.87	5.4	Operation not recommended							
30	10.0	2.3	5.3	Operation not recommended							Operation not recommended							
	13.0	3.5	8.0	1400	35.5	3.38	23.9	93.5	3.07	6.1	1400	54.0	33.0	0.61	1.78	60.1	30.3	---
				1700	37.2	3.43	25.5	90.3	3.18	5.6	1700	55.9	37.9	0.68	1.90	62.4	29.4	---
	16.0	4.9	11.3	1400	37.0	3.38	25.5	94.5	3.21	6.3	1400	54.1	32.9	0.61	1.71	59.9	31.6	---
1700				38.8	3.43	27.1	91.1	3.32	5.7	1700	55.7	37.8	0.68	1.84	61.9	30.2	---	
40	10.0	2.2	5.1	Operation not recommended							Operation not recommended							
	13.0	3.4	7.8	1400	41.7	3.48	29.8	97.6	3.51	6.5	1400	56.5	35.0	0.62	1.96	63.2	28.9	---
				1700	43.5	3.49	31.6	93.7	3.65	5.9	1700	58.3	39.9	0.68	2.07	65.4	28.1	---
	16.0	4.7	11.0	1400	43.2	3.49	31.3	98.6	3.62	6.7	1400	56.6	34.9	0.62	1.90	63.1	29.9	---
1700				45.1	3.50	33.1	94.6	3.77	6.1	1700	58.3	39.9	0.68	2.02	65.2	28.9	---	
50	10.0	2.1	4.9	1400	46.6	3.52	34.6	100.8	3.88	6.8	1400	58.5	36.5	0.62	2.26	66.2	25.9	2.3
				1700	48.7	3.49	36.8	96.5	4.10	6.3	1700	60.3	41.4	0.69	2.37	68.4	25.4	2.4
	13.0	3.3	7.5	1400	47.3	3.56	35.2	101.3	3.89	7.0	1400	58.7	36.8	0.63	2.18	66.1	26.9	2.1
				1700	49.2	3.54	37.1	96.8	4.07	6.4	1700	60.5	41.8	0.69	2.29	68.3	26.4	2.3
16.0	4.6	10.6	1400	48.7	3.58	36.5	102.2	3.99	7.2	1400	58.8	36.8	0.63	2.12	66.1	27.7	2.0	
			1700	50.8	3.56	38.6	97.7	4.18	6.6	1700	60.6	41.8	0.69	2.24	68.3	27.1	2.2	
60	10.0	2.1	4.8	1400	51.8	3.64	39.4	104.3	4.18	7.5	1400	56.8	36.0	0.63	2.48	65.3	22.9	3.2
				1700	54.0	3.56	41.9	99.4	4.45	6.9	1700	58.5	40.7	0.70	2.59	67.4	22.6	3.4
	13.0	3.2	7.3	1400	53.3	3.67	40.8	105.3	4.25	7.7	1400	57.1	36.4	0.64	2.40	65.2	23.8	3.0
				1700	55.4	3.61	43.1	100.2	4.50	7.1	1700	58.8	41.2	0.70	2.51	67.3	23.4	3.2
16.0	4.4	10.3	1400	54.5	3.71	41.9	106.1	4.30	7.9	1400	57.3	36.5	0.64	2.35	65.3	24.4	2.8	
			1700	56.7	3.65	44.3	100.9	4.56	7.3	1700	59.1	41.2	0.70	2.45	67.4	24.1	3.1	
70	10.0	2.0	4.6	1400	57.2	3.77	44.3	107.8	4.45	8.3	1400	56.4	36.6	0.65	2.77	65.9	20.4	4.5
				1700	59.5	3.66	47.0	102.4	4.77	7.7	1700	58.1	41.2	0.71	2.88	67.9	20.2	4.8
	13.0	3.0	7.0	1400	59.3	3.80	46.4	109.3	4.57	8.5	1400	56.8	37.0	0.65	2.68	65.9	21.2	4.2
				1700	61.7	3.69	49.1	103.6	4.89	7.9	1700	58.4	41.7	0.71	2.79	67.9	20.9	4.5
16.0	4.3	9.9	1400	60.4	3.86	47.3	110.0	4.59	8.8	1400	57.1	37.2	0.65	2.65	66.1	21.6	3.9	
			1700	62.7	3.75	50.0	104.2	4.91	8.1	1700	58.9	41.8	0.71	2.74	68.2	21.5	4.3	
80	10.0	1.9	4.5	1400	61.6	3.86	48.4	110.7	4.67	9.2	1400	53.8	35.8	0.66	3.09	64.4	17.4	6.2
				1700	63.9	3.72	51.1	104.8	5.02	8.5	1700	55.5	40.0	0.72	3.18	66.3	17.5	6.6
	13.0	2.9	6.8	1400	64.8	3.91	51.5	112.9	4.86	9.5	1400	54.3	36.2	0.67	3.01	64.5	18.0	5.8
				1700	67.2	3.75	54.4	106.6	5.25	8.8	1700	55.9	40.5	0.72	3.10	66.5	18.0	6.3
16.0	4.2	9.6	1400	65.6	3.96	52.1	113.4	4.85	9.8	1400	54.7	36.4	0.67	2.96	64.8	18.5	5.4	
			1700	67.8	3.82	54.8	107.0	5.21	9.1	1700	56.4	40.7	0.72	3.04	66.8	18.5	6.0	
90	10.0	1.9	4.3	1400	66.1	3.98	52.6	113.7	4.87	10.3	1400	49.7	34.0	0.68	3.43	61.4	14.5	8.3
				1700	68.3	3.81	55.3	107.2	5.25	9.5	1700	51.3	37.7	0.74	3.50	63.2	14.6	8.8
	13.0	2.8	6.6	1400	70.4	4.03	56.7	116.6	5.12	10.6	1400	50.2	34.3	0.68	3.36	61.7	14.9	7.7
				1700	72.8	3.83	59.7	109.6	5.57	9.8	1700	51.8	38.2	0.74	3.43	63.5	15.1	8.4
16.0	4.0	9.3	1400	70.9	4.09	56.9	116.9	5.08	11.0	1400	50.7	34.6	0.68	3.31	62.0	15.3	7.2	
			1700	73.1	3.90	59.8	109.8	5.49	10.2	1700	52.3	38.5	0.74	3.38	63.8	15.5	8.0	
100	10.0	1.8	4.2	Operation not recommended							Operation not recommended							
	13.0	2.7	6.3	1400	48.2	3.42	34.2	107.2	5.25	9.5	1400	48.2	34.2	0.71	3.80	61.1	12.7	10.0
				1700	49.7	3.79	37.9	107.2	5.25	9.5	1700	49.7	37.9	0.76	3.84	62.8	12.9	10.9
	16.0	3.9	8.9	1400	48.8	3.46	34.6	107.2	5.25	9.5	1400	48.8	34.6	0.71	3.74	61.6	13.0	9.3
1700				50.3	3.83	38.3	107.2	5.25	9.5	1700	50.3	38.3	0.76	3.79	63.2	13.3	10.4	
110	10.0	1.7	4.0	Operation not recommended							Operation not recommended							
	13.0	2.6	6.1	1400	42.8	3.21	32.1	107.2	5.25	9.5	1400	42.8	32.1	0.75	4.24	57.3	10.1	12.7
				1700	44.3	3.53	35.3	107.2	5.25	9.5	1700	44.3	35.3	0.80	4.26	58.8	10.4	13.8
	16.0	3.7	8.6	1400	43.5	3.26	32.6	107.2	5.25	9.5	1400	43.5	32.6	0.75	4.19	57.8	10.4	11.8
1700				44.8	3.58	35.8	107.2	5.25	9.5	1700	44.8	35.8	0.80	4.20	59.1	10.7	13.1	
120	10.0	1.7	3.8	Operation not recommended							Operation not recommended							
	13.0	2.5	5.8	1400	40.0	3.12	31.2	107.2	5.25	9.5	1400	40.0	31.2	0.78	4.79	56.3	8.4	15.8
				1700	41.5	3.42	34.2	107.2	5.25	9.5	1700	41.5	34.2	0.83	4.76	57.7	8.7	17.1
	16.0	3.6	8.2	1400	40.8	3.18	31.8	107.2	5.25	9.5	1400	40.8	31.8	0.78	4.70	56.9	8.7	14.6
1700				42.0	3.48	34.8	107.2	5.25	9.5	1700	42.0	34.8	0.83	4.70	58.0	8.9	16.3	

NB072 - Performance Data

Dual Capacity with Variable Speed ECM or 5-Speed ECM High Speed (2200 cfm)

EWT °F	Flow Rate gpm	Water Pressure Drop		HEATING - EAT 70°F							COOLING - EAT 80/67 °F							
		psi	ft/hd	Airflow cfm	HC MBtu/h	Power kW	HE MBtu/h	LAT °F	COP	HWC MBtu/h	Airflow cfm	TC MBtu/h	SC MBtu/h	S/T Ratio	Power kW	HR MBtu/h	EER	HWC MBtu/h
20	12.0	3.3	7.6	Operation not recommended							Operation not recommended							
	15.0	4.6	10.7	Operation not recommended							Operation not recommended							
	18.0	6.2	14.3	1850	45.4	4.17	31.2	92.7	3.19	7.9	Operation not recommended							
				2200	47.1	4.44	31.9	89.8	3.11	7.1	Operation not recommended							
30	12.0	3.2	7.4	Operation not recommended							Operation not recommended							
	15.0	4.5	10.4	1850	52.6	4.33	37.8	96.3	3.56	8.3	1850	70.5	43.0	0.61	2.51	79.1	28.1	---
				2200	54.5	4.60	38.7	92.9	3.47	7.6	2200	71.8	46.8	0.65	2.66	80.9	27.0	---
	18.0	6.0	13.9	1850	53.0	4.37	38.1	96.5	3.56	8.6	1850	71.2	43.8	0.61	2.46	79.6	28.9	---
2200				55.0	4.65	39.1	93.1	3.47	7.8	2200	72.5	47.1	0.65	2.62	81.5	27.7	---	
40	12.0	3.1	7.1	Operation not recommended							Operation not recommended							
	15.0	4.4	10.1	1850	61.0	4.60	45.3	100.5	3.89	9.2	1850	73.3	45.8	0.62	3.03	83.6	24.2	---
				2200	63.1	4.81	46.7	96.5	3.84	8.4	2200	74.7	49.8	0.67	3.21	85.7	23.3	---
	18.0	5.8	13.5	1850	61.9	4.65	46.0	101.0	3.90	9.5	1850	74.1	46.6	0.63	2.97	84.2	24.9	---
2200				64.0	4.86	47.4	96.9	3.86	8.6	2200	75.5	50.2	0.66	3.16	86.3	23.9	---	
50	12.0	3.0	6.9	1850	64.9	4.79	48.6	102.5	3.97	9.9	1850	74.7	47.6	0.64	3.68	87.2	20.3	4.3
				2200	67.1	4.96	50.2	98.2	3.97	9.2	2200	76.2	51.8	0.68	3.90	89.6	19.5	4.6
	15.0	4.2	9.8	1850	68.6	4.88	51.9	104.3	4.12	10.3	1850	75.4	48.1	0.64	3.60	87.7	21.0	4.0
				2200	70.9	5.04	53.7	99.8	4.12	9.4	2200	76.9	52.4	0.68	3.83	90.0	20.1	4.4
18.0	5.7	13.1	1850	69.8	4.94	53.0	104.9	4.14	10.6	1850	76.2	49.1	0.64	3.54	88.3	21.5	3.7	
			2200	72.1	5.09	54.7	100.3	4.15	9.7	2200	77.7	52.8	0.68	3.77	90.6	20.6	4.2	
60	12.0	2.9	6.7	1850	73.0	5.10	55.6	106.5	4.19	11.1	1850	73.3	47.7	0.65	3.91	86.7	18.8	5.3
				2200	75.4	5.20	57.6	101.7	4.24	10.3	2200	74.9	51.6	0.69	4.15	89.0	18.0	5.6
	15.0	4.1	9.5	1850	76.2	5.19	58.5	108.2	4.30	11.5	1850	74.1	48.2	0.65	3.82	87.1	19.4	4.9
				2200	78.7	5.27	60.7	103.1	4.37	10.6	2200	75.6	52.1	0.69	4.06	89.4	18.6	5.3
18.0	5.5	12.7	1850	77.9	5.25	60.0	109.0	4.35	11.8	1850	74.9	48.9	0.65	3.76	87.7	19.9	4.6	
			2200	80.5	5.33	62.3	103.9	4.43	10.9	2200	76.4	52.7	0.69	4.00	90.0	19.1	5.1	
70	12.0	2.8	6.5	1850	81.2	5.42	62.7	110.6	4.39	12.5	1850	73.3	48.7	0.66	4.34	88.1	16.9	6.6
				2200	83.7	5.46	65.1	105.2	4.49	11.6	2200	74.8	52.3	0.70	4.62	90.6	16.2	7.0
	15.0	4.0	9.1	1850	84.0	5.51	65.2	112.0	4.47	12.9	1850	74.0	49.2	0.66	4.26	88.5	17.4	6.2
				2200	86.7	5.52	67.8	106.5	4.60	11.9	2200	75.5	52.8	0.70	4.52	91.0	16.7	6.7
18.0	5.3	12.2	1850	86.2	5.57	67.2	113.1	4.53	13.3	1850	74.8	49.7	0.66	4.18	89.1	17.9	5.7	
			2200	89.0	5.57	70.0	107.5	4.68	12.3	2200	76.4	53.4	0.70	4.45	91.5	17.1	6.4	
80	12.0	2.7	6.3	1850	88.3	5.78	68.6	114.2	4.48	14.1	1850	70.1	47.4	0.68	4.67	86.0	15.0	8.4
				2200	91.2	5.74	71.6	108.4	4.66	13.0	2200	71.6	51.2	0.72	4.97	88.5	14.4	8.9
	15.0	3.8	8.8	1850	90.4	5.86	70.4	115.3	4.52	14.5	1850	70.8	47.8	0.68	4.57	86.4	15.5	7.8
				2200	93.3	5.78	73.6	109.3	4.73	13.4	2200	72.2	51.6	0.71	4.86	88.8	14.9	8.4
18.0	5.1	11.8	1850	93.2	5.94	72.9	116.6	4.60	15.0	1850	71.6	48.5	0.68	4.49	86.9	15.9	7.2	
			2200	96.3	5.84	76.3	110.5	4.83	13.8	2200	73.0	52.2	0.71	4.79	89.4	15.3	8.0	
90	12.0	2.6	6.0	1850	95.6	6.15	74.6	117.9	4.56	15.8	1850	65.5	45.0	0.69	4.88	82.2	13.4	10.5
				2200	98.8	6.03	78.2	111.6	4.80	14.7	2200	66.9	48.9	0.73	5.19	84.6	12.9	11.1
	15.0	3.7	8.5	1850	97.0	6.22	75.7	118.5	4.57	16.3	1850	66.2	45.4	0.69	4.78	82.5	13.9	9.8
				2200	100.1	6.06	79.4	112.1	4.84	15.1	2200	67.5	49.3	0.73	5.09	84.9	13.3	10.6
18.0	4.9	11.4	1850	100.3	6.30	78.8	120.2	4.66	16.8	1850	66.9	46.3	0.69	4.70	82.9	14.2	9.1	
			2200	103.6	6.12	82.7	113.6	4.96	15.6	2200	68.3	49.8	0.73	5.00	85.3	13.6	10.1	
100	12.0	2.5	5.8	Operation not recommended							Operation not recommended							
	15.0	3.6	8.2	Operation not recommended							1850	63.4	44.7	0.71	5.27	81.4	12.0	12.2
				2200	64.7	48.4	0.75	5.61	83.9	11.5	13.2							
	18.0	4.8	11.0	Operation not recommended							1850	64.1	45.4	0.71	5.18	81.8	12.4	11.3
2200				65.5	48.9	0.75	5.51	84.3	11.9	12.5								
110	12.0	2.4	5.6	Operation not recommended							Operation not recommended							
	15.0	3.4	7.9	Operation not recommended							1850	56.6	41.4	0.73	5.51	75.4	10.3	14.9
				2200	57.8	44.6	0.77	5.86	77.8	9.9	16.1							
	18.0	4.6	10.6	Operation not recommended							1850	57.3	41.9	0.73	5.41	75.7	10.6	13.8
2200				58.4	45.0	0.77	5.76	78.1	10.2	15.3								
120	12.0	2.3	5.4	Operation not recommended							Operation not recommended							
	15.0	3.3	7.6	Operation not recommended							1850	53.6	40.2	0.75	6.04	74.3	8.9	18.0
				2200	54.7	43.4	0.79	6.43	76.7	8.5	19.5							
	18.0	4.4	10.2	Operation not recommended							1850	54.2	40.7	0.75	5.94	74.5	9.1	16.7
2200				55.3	43.7	0.79	6.31	76.9	8.8	18.5								

Wiring Schematics

Aurora Control 460/60/3 Variable Speed ECM

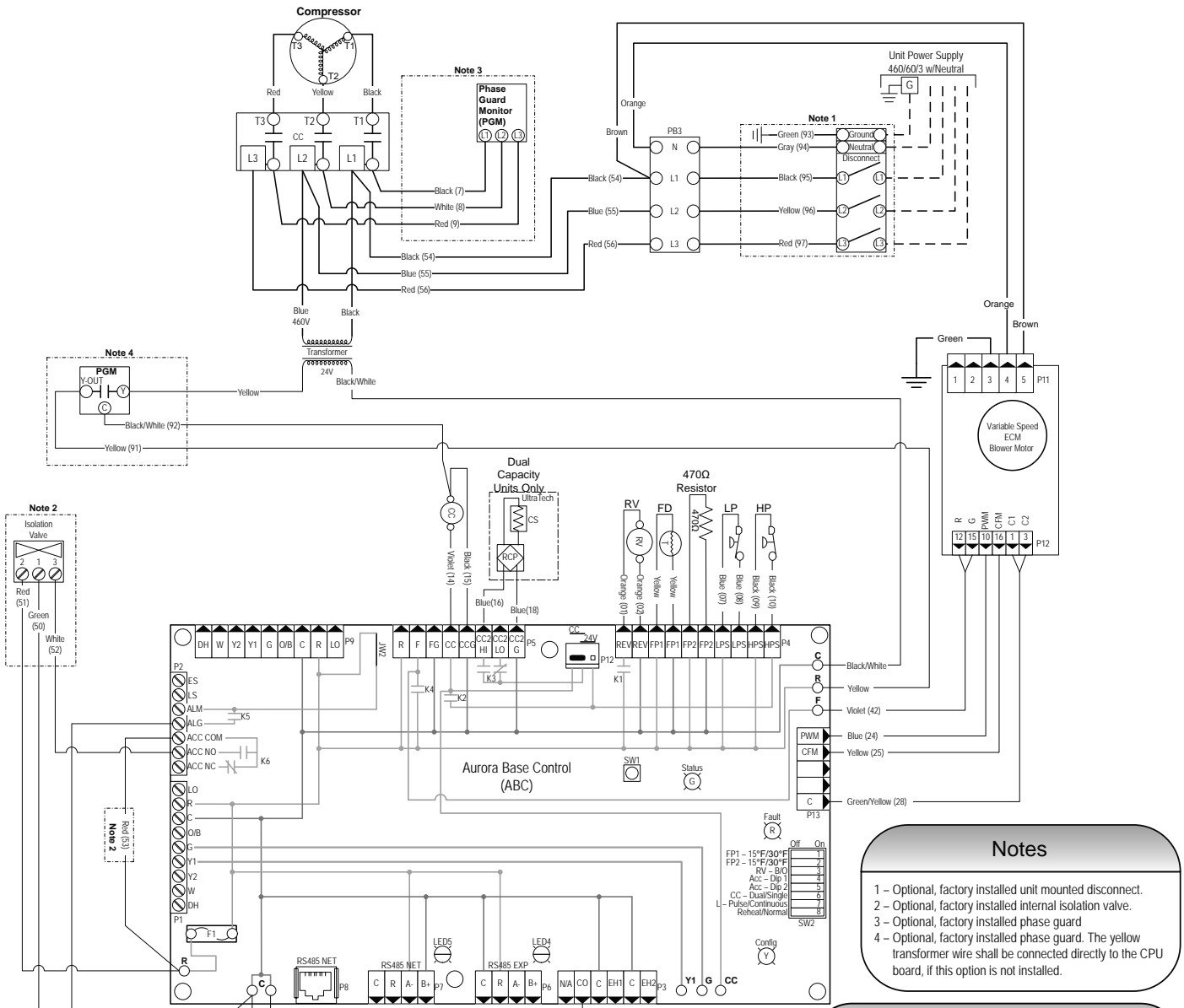

- ### Notes
- 1 - Optional, factory installed unit mounted disconnect.
 - 2 - Optional, factory installed internal isolation valve.
 - 3 - Optional, factory installed phase guard.
 - 4 - Optional, factory installed phase guard. The yellow transformer wire shall be connected directly to the CPU board, if this option is not installed.

Legend

	Factory Low Voltage Wiring		Thermistor
	Factory Line Voltage Wiring		Relay Coil
	Field Low Voltage Wiring		Switch - Condensate Overflow
	Field Line Voltage Wiring		Switch - High pressure
	Optional Block		Switch - Low pressure
	DC Voltage PCB Traces		Polarized connector
	Field Zone Sensor Wiring		Light Emitting Diode - Green
	Internal Junction		Light Emitting Diode - Yellow
	Quick Connect Terminal		Light Emitting Diode - Red
	Field Wiring Lug		SW2 - DIP package 8 position
	Ground		SW1 - Push button
	Relay Contacts - N.O., N.C.		HP - Blower Relay
	Capacitor		RV - Reversing Valve Coil
	Fuse		PGM - Phase Guard Monitor
			RH - Reheat Valve Coil

Accessory Relay		
Operation	SW2-4	SW2-3
Cycle with Blower	On	On
Cycle with Compressor	Off	Off
Water Valve Shut Open	On	Off
Outdoor Air Damper	Off	On

Aurora Timing Events		
Event	Normal Mode	Test Mode
Random Start Delay	5 to 80 seconds	1 second
Compressor On Delay	5 seconds	< 1 second
Compressor Minimum On Time	2 minutes	5 seconds
Compressor Short Cycle Delay	4 minutes	15 seconds
Blower Off Delay	30 seconds	2 seconds
Fault Recognition Delay - High Pressure	Less than 1 second	Less than 1 second
Start-Up Bypass - Low Pressure	30 seconds	30 seconds
Fault Recognition Delay - Low Pressure	30 seconds	30 seconds
Start-Up Bypass - Low Water/Air Coil Limit	2 minutes	30 seconds
Fault Recognition Delay - Low Water/Air Coil Limit	30 seconds	30 seconds
Fault Recognition Delay - Condensate Overflow	30 seconds	30 seconds
Thermostat Call Recognition Time	2 seconds	2 seconds
Auxiliary Heat Staging Delay	5 minutes	20 seconds
Emergency Heat Staging Delay	2 minutes	30 seconds
Water Valve Slow Open Delay	90 seconds	90 seconds
Reheat Delay	30 seconds	30 seconds

Aurora LED Flash Codes			
Slow Flash	1 second on and 1 second off		
Fast Flash	100 milliseconds on and 100 milliseconds off		
Flash Code	100 milliseconds on and 400 milliseconds off with a 2 second pause before repeating		
Status LED (LED1, Green)	Configuration LED (LED2, Yellow)	Fault LED (LED3, Red)	Random Start Delay
Normal Mode	ON	No Software Override	Fast Flash
Control is Non-Functional	OFF	DIP Switch Override	Slow Flash
Test Mode	Slow Flash	ECM Configure Mode	Fast Flash
Lockout Active	Fast Flash	Reset Configure Mode	Off
Status LED (LED1, Green)	Configuration LED (LED2, Yellow)	Fault LED (LED3, Red)	Normal Mode
Normal Mode	ON	No Software Override	Flash ECM Setting
Control is Non-Functional	OFF	DIP Switch Override	Slow Flash
Test Mode	Slow Flash	ECM Configure Mode	Fast Flash
Lockout Active	Fast Flash	Reset Configure Mode	Off
Dehumidification Mode	Flash Code 2	Low Air Coil Limit Lockout - FP2	Flash Code 4
Reserved	Flash Code 3	Low Water Coil Limit Lockout - FP1	Flash Code 5
Reserved	Flash Code 4	Reserved	Flash Code 6
Load Shed	Flash Code 5	Condensate Overflow Lockout	Flash Code 7
ESD	Flash Code 6	Over/Under Voltage Shutdown	Flash Code 8
Reserved	Flash Code 7	Reserved	Flash Code 9
		Reserved	Flash Code 10
		Air/Water Coil Limit Sensor Error	Flash Code 11

Wiring Schematics cont.

Aurora Base Control 460/60/3 5-Speed ECM with Reheat

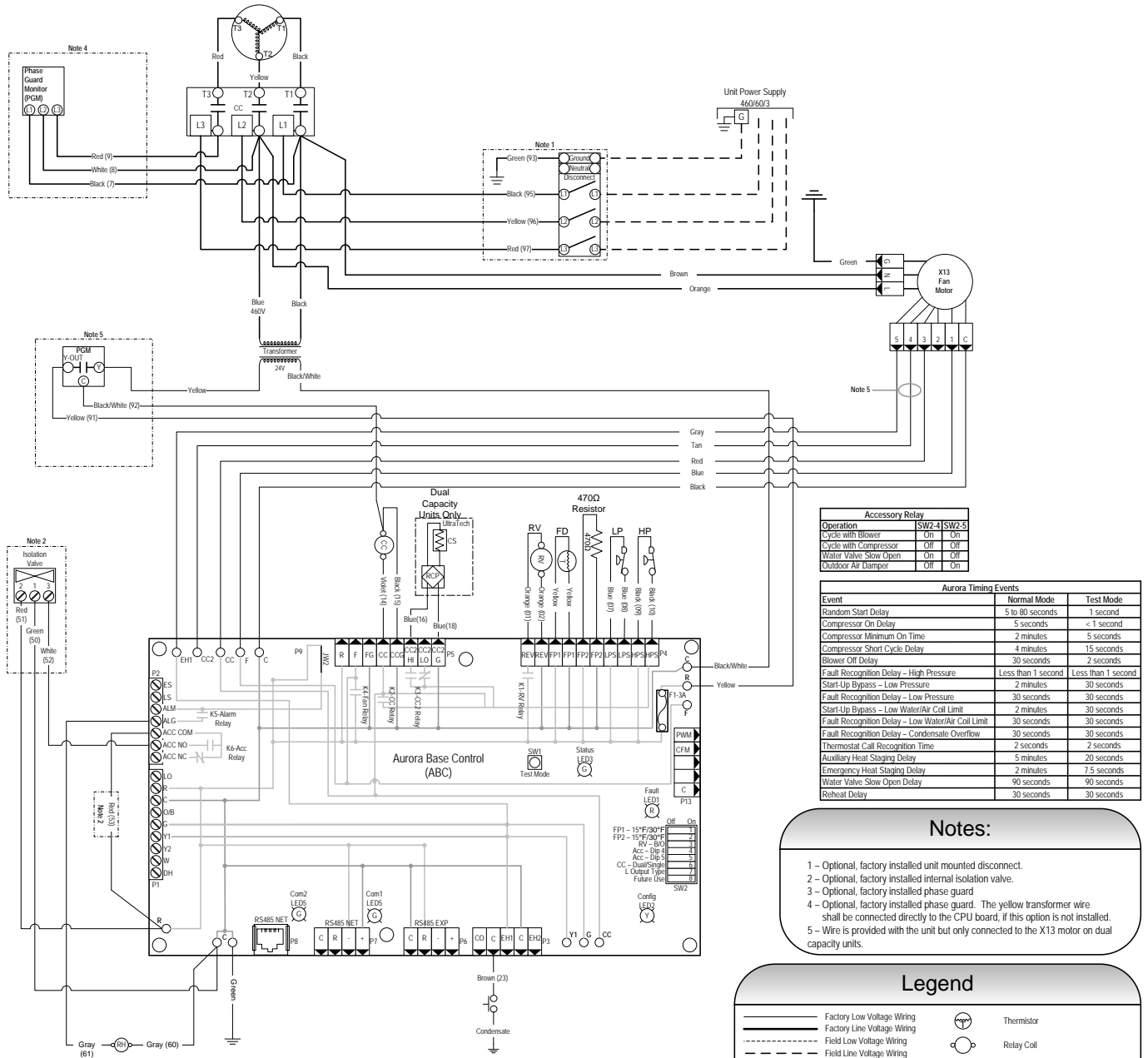

Accessory Relay		
Operation	SW2-4	SW2-5
Cycle with Blower	On	On
Cycle with Compressor	Off	Off
Water Valve Slow Open	On	Off
Outdoor Air Bumper	Off	On

Aurora Timing Events		
Event	Normal Mode	Test Mode
Random Start Delay	5 to 80 seconds	1 second
Compressor On Delay	5 seconds	< 1 second
Compressor Minimum On Time	2 minutes	5 seconds
Compressor Short Cycle Delay	4 minutes	15 seconds
Blower Off Delay	30 seconds	2 seconds
Fault Recognition Delay - High Pressure	Less than 1 second	Less than 1 second
Start-Up Bypass - Low Pressure	2 minutes	30 seconds
Fault Recognition Delay - Low Pressure	30 seconds	30 seconds
Start-Up Bypass - Low Water/Air Coil Limit	2 minutes	30 seconds
Fault Recognition Delay - Low Water/Air Coil Limit	30 seconds	30 seconds
Fault Recognition Delay - Condensate Overflow	30 seconds	30 seconds
Thermostat Call Recognition Time	2 seconds	2 seconds
Auxiliary Heat Staging Delay	5 minutes	20 seconds
Emergency Heat Staging Delay	2 minutes	7.5 seconds
Water Valve Slow Open Delay	90 seconds	90 seconds
Reheat Delay	30 seconds	30 seconds

Notes:

- 1 - Optional, factory installed unit mounted disconnect.
- 2 - Optional, factory installed internal isolation valve.
- 3 - Optional, factory installed phase guard.
- 4 - Optional, factory installed phase guard. The yellow transformer wire shall be connected directly to the CPU board, if this option is not installed.
- 5 - Wire is provided with the unit but only connected to the X13 motor on dual capacity units.

Legend

	Factory Low Voltage Wiring		Thermistor
	Factory Line Voltage Wiring		Relay Coil
	Field Low Voltage Wiring		Switch - Condensate Overflow
	Field Line Voltage Wiring		Switch - High Pressure
	Optional Block		Switch - Low Pressure
	DC Voltage PCB Traces		Quick Connect Terminal
	Field Zone Sensor Wiring		Field Wiring Lug
	Internal Junction		Polarized connector
	Quick Connect Terminal		Relay Contacts - N.O., N.C.
	Capacitor		Light Emitting Diode - Green
	Fuse		Light Emitting Diode - Yellow
			Light Emitting Diode - Red

CC - Compressor Contactor
 CO - Condensate Overflow Sensor
 ES - Emergency Shutdown
 HP - High Pressure Switch
 LP - Low Pressure Switch
 FD - Freeze Detection Sensor
 F1 - Fuse
 SW1 - Push button
 SW2 - DIP package 8 position
 RB - Blower Relay
 RV - Reversing Valve Coil
 PGM - Phase Guard Monitor
 RH - Reheat Valve Coil

Aurora LED Flash Codes					
Slow Flash	1 second on and 1 second off				
Fast Flash	100 milliseconds on and 100 milliseconds off				
Flash Code	100 milliseconds on and 400 milliseconds off with a 2 second pause before repeating				
Random Start Delay					
Status LED (LED1, Green)	Fast Flash				
Configuration LED (LED2, Yellow)	Fast Flash				
Fault LED (LED3, Red)	Fast Flash				
Status LED (LED1, Green)	Configuration LED (LED2, Yellow)	Flash ECM Setting		Normal Mode	OFF
Normal Mode	ON	No Software Override	Flash ECM Setting	Normal Mode	OFF
Control is Non-Functional	OFF	DIP Switch Override	Slow Flash	Input Fault Lockout	Flash Code 1
Test Mode	Slow Flash	ECM Configure Mode	Fast Flash	High Pressure Lockout	Flash Code 2
Lockout Active	Fast Flash	Reset Configure Mode	Off	Low Pressure Lockout	Flash Code 3
Dehumidification Mode	Flash Code 2			Low Air Coil Limit Lockout - FP2	Flash Code 4
Reserved	Flash Code 3			Low Water Coil Limit Lockout - FPI	Flash Code 5
Reserved	Flash Code 4			Condensate Overflow Lockout	Flash Code 7
Load Shed	Flash Code 5			Over/Under Voltage Shutdown	Flash Code 8
ESD	Flash Code 6			Reserved	Flash Code 9
Reserved	Flash Code 7			Reserved	Flash Code 10
				Air/Water Coil Limit Sensor Error	Flash Code 11

Wiring Schematics cont.

Aurora Control with UPC

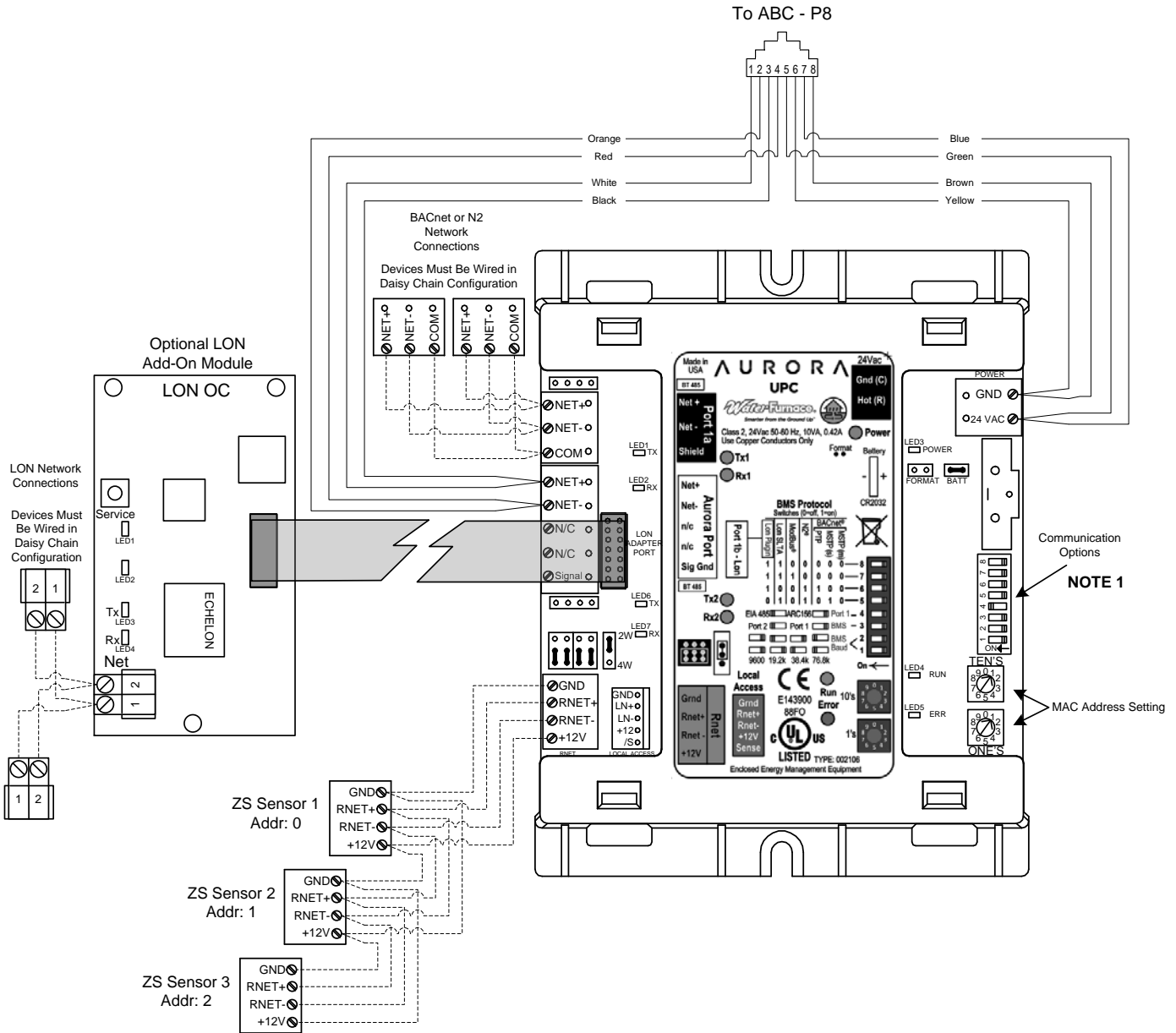

ZS Sensor Information

Zone Sensors can be wired in daisy chain as show or in a star or hybrid configuration. Maximum of 5 sensors per UPC. Maximum allowable load 210mA. See the UPC install manual for possible sensor combinations.

DIP Switch Value



Each ZS sensor must have a unique address, but the addresses do not need to be sequential. Use the DIP switches on the back of the ZS sensor to set an address from 0 to 4. (0 is the factory default.) Each DIP switch has the value shown in the figure to the left. Turn on as many DIP switches as you need so that their total value equals the address.

Notes

1. Use DIP Switches 5 – 8 to change communication protocol and DIP switches 1 – 2 to change BACnet baud rate

Legend

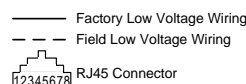

Engineering Guide Specifications

General

Furnish and install WaterFurnace Water Source Heat Pumps as indicated on the plans. Equipment shall be completely assembled, piped and internally wired. Capacities and characteristics as listed in the schedule and the specifications that follow. The reverse cycle heating/cooling units shall be either suspended type with horizontal air inlet and discharge or floor mounted type with horizontal air inlet and vertical upflow air discharge. Units shall be AHRI/ISO 13256-1 certified and listed by a nationally recognized safety-testing laboratory or agency, such as ETL Testing Laboratory. Each unit shall be computer run-tested at the factory with conditioned water and operation verified to catalog data. Each unit shall be mounted on a pallet and shipped in a corrugated box or stretch-wrapped. The units shall be designed to operate with entering liquid temperature between 20°F and 120°F [-6.7°C and 48.9°C].

Casing and Cabinet

The cabinet shall be fabricated from heavy-gauge galvanized steel and finished with optional corrosion-resistant powder coating. This corrosion protection system shall meet the stringent 1000 hour salt spray test per ASTM B117. The interior shall be insulated with 1/2 in. thick, multi-density, cleanable aluminum foil coated glass fiber with edges sealed or tucked under flanges to prevent the introduction of glass fibers into the discharge air. Standard cabinet panel insulation must meet NFPA 90A requirements, air erosion and mold growth limits of UL-181, stringent fungal resistance test per ASTM-C1071 and ASTM G21, and shall meet zero level bacteria growth per ASTM G22. Unit insulation must meet these stringent requirements or unit(s) will not be accepted.

One (horizontal) to two (vertical) blower and two compressor compartment access panels shall be 'lift-out' removable with supply and return ductwork in place.

A duct collar shall be provided on the supply air opening. Standard size 1 in. [2.54 cm] MERV 4 filters shall be provided with each unit. Units shall have a return air filter rack that is field convertible from 1 in. [2.54 cm] to 2 in. [5.1 cm]. The units shall have an insulated divider panel between the air handling section and the compressor section to minimize the transmission of compressor noise. Vertical units shall be supplied with left or right horizontal air inlet and top vertical air discharge. Horizontal units shall be supplied with left or right air inlet and side or end air discharge.

The compressor shall be double isolation mounted using selected durometer grommets to provide vibration free compressor mounting. The compressor mounting bracket shall be acoustically deadened galvanized steel to prevent vibration transmission to the cabinet.

Option: AlpinePure MERV 13 filter - A 2 in. thick [51 mm] MERV 13 filter can help fulfill a credit under the LEED Rating System. Its low initial resistance promotes low energy consumption (0.21 in. w.g. @ 300 fpm) and provides nearly twice the life of a standard filter (300 fpm vs. standard 500 fpm application).

Option: A Super Quiet Sound package shall include multi-density full coverage compressor blanket.

Option: An internally mounted low pressure drop (high Cv) water solenoid valve shall be factory installed for use in variable speed pumping applications.

Option: An internally mounted automatic flow regulator shall be set to 3 gpm/ton to deliver optimal flow to the unit.

Refrigerant Circuit

All units shall utilize the non-ozone depleting and low global warming potential refrigerant R-410A. All units shall contain a sealed refrigerant circuit including a hermetic motor-compressor, bidirectional thermostatic expansion valve, finned tube air-to-refrigerant heat exchanger, reversing valve, coaxial tube water-to-refrigerant heat exchanger, optional hot water generator coil, and service ports.

Compressors shall be high-efficiency single speed rotary or scroll type designed for heat pump duty and mounted on vibration isolators. The compressor shall be double isolation mounted using selected durometer grommets to provide vibration free compressor mounting.

Option: AlumiSeal electro-coated air coil.

The coaxial water-to-refrigerant heat exchanger shall be designed for low water pressure drop and constructed of a convoluted copper (cupronickel option) inner tube and a steel outer tube. Refrigerant to air heat exchangers shall utilize enhanced corrugated lanced aluminum fins and rifled aluminum tube construction rated to withstand 600 psig (4135 kPa) refrigerant working pressure. Refrigerant to water heat exchangers shall be of copper inner water tube and steel refrigerant outer tube design, rated to withstand 600 psig (4135 kPa) working refrigerant pressure and 450 psig (3101 kPa) working water pressure.

The thermostatic expansion valve shall provide proper superheat over the entire liquid temperature range with minimal "hunting." The valve shall operate bidirectionally without the use of check valves.

Engineering Guide Specifications cont.

Option: Cupronickel refrigerant to water heat exchanger shall be of copper-nickel inner water tube and steel refrigerant outer tube design, rated to withstand 600 psig (4135 kPa) working refrigerant pressure and 450 psig (3101 kPa) working water pressure. Water lines shall also be of cupronickel construction.

Option: Hot water generator - Internal double wall vented hot water generator coil refrigerant to water heat exchangers shall be of copper inner water tube and steel refrigerant outer tube design, rated to withstand 600 psig (4135 kPa) working refrigerant pressure and 450 psig (3101 kPa) working water pressure.

Option: ThermaShield coated water-to-refrigerant heat exchanger, water lines and refrigerant suction lines shall be insulated to prevent condensation at low liquid temperatures below 50°F.

Option: AlpinePure hot gas bypass

Option: AlpinePure hot gas reheat

Blower Motor and Assembly

The blower shall be a direct drive centrifugal type with a dynamically balanced wheel. The housing and wheel shall be designed for quiet low outlet velocity operation. The blower housing shall be removable from the unit without disconnecting the supply air ductwork for servicing of the blower motor. The blower motor shall be isolated from the housing by rubber grommets. The motor shall be permanently lubricated and have thermostatic overload protection.

Option: PSC blower motor shall be a three-speed PSC type.

Option: 5-Speed ECM blower motor shall be a 5-speed ECM type. The 5-speed ECM blower motor shall be soft starting, shall maintain constant torque over its operating static range, and shall provide 5 speed settings. The blower motor shall be isolated from the housing by rubber grommets. The motor shall be permanently lubricated and have thermostatic overload protection. 5-speed ECM motors shall be long-life ball bearing type.

Option: Variable speed ECM blower motor shall be a variable speed ECM type. The variable speed ECM blower motor shall be soft starting, shall maintain constant cfm over its operating static range, and shall provide 12 cfm settings. Variable speed ECM motors shall be long-life ball bearing type.

Option: High static blower motors shall be available on certain PSC and variable speed ECM models.

Electrical

A control box shall be located within the unit compressor compartment and shall contain a 50VA or 75VA transformer, 24 volt activated, 2 pole compressor contactor, terminal block for thermostat wiring and solid-state controller for complete unit operation. Electromechanical operation WILL NOT be accepted. Units shall be name-plated for use with time delay fuses or HACR circuit breakers. Unit controls shall be 24 volt and provide heating or cooling as required by the remote thermostat/sensor.

An Aurora microprocessor-based controller that interfaces with a multi-stage electronic thermostat to monitor and control unit operation shall be provided. The control shall provide operational sequencing, blower speed control, high and low pressure switch monitoring, freeze detection, condensate overflow sensing, lockout mode control, LED status and fault indicators, fault memory, field selectable options and accessory output. The control shall provide fault retry three times before locking out to limit nuisance trips.

A detachable terminal block with screw terminals will be provided for field control wiring. All units shall have knockouts for entrance of low and line voltage wiring. The blower motor and control box shall be harness plug wired for easy removal.

Option: An Aurora Unitary Protocol Converter (UPC) shall be included that communicates directly with the Aurora Heat Pump Controls and allows access/control of a variety of internal Aurora heat pump operations such as sensors, relay operation, faults and other information. In turn, the UPC shall convert the internal Aurora Modbus protocol to BACnet MS/TP, or N2 protocols for communication over a BAS system. Additional individual unit configuration items such as ECM fan speeds or freeze protection settings shall be directly available over the BAS without the need for access to the actual heat pump.

Option: Aurora UPC DDC communication protocols: LonWorks

Option: IntelliStart® (compressor soft starter) shall be factory installed for use in applications that require low starting amps, reduced compressor start-up noise, off-grid, and improved start-up behavior. IntelliStart shall reduce normal starting current up to 60%.

Engineering Guide Specifications cont.

Piping

Supply and return water connections shall be FPT copper fittings fixed to the corner post, which eliminate the need for backup pipe wrenches.

With vertical units, the condensate connection shall be a 3/4 in. [19.1 mm] PVC socket with internally-trapped hose that can be routed to front or side corner post locations.

Hanger Kit

(included with horizontal units only - field installed)

The hanger kit shall consist of galvanized steel brackets, bolts, lock washers, and isolators and shall be designed to fasten to the unit bottom panel for suspension from 3/8 in. threaded rods. Unit sizes 009-060 shall require four brackets and unit sizes 070-072 shall require five brackets. Brackets shall not inhibit filter removal in any way.

Accessories

Thermostat (field-installed)

A multi-stage auto-changeover electronic digital thermostat shall be provided. The thermostat shall offer two heating stages and one cooling stage with precise temperature control. An OFF-HEAT-AUTO-COOL-EMERG system switch, OFF-AUTO blower switch, and indicating LEDs shall be provided. The thermostat shall display in °F or °C.

Hose Kits - Ball Valves (field-installed)

A flexible steel braid hose featuring Kevlar[®] reinforced EPDM core with ANSI 302/304 stainless steel outer braid and fire rated materials per ASTM E 84-00 (NFPA 255, ANSI/UL 723 & UBC 8-1). Ball valve at one end; swivel connector with adapter at the other end (swivel to adapter connection via fiber or EPDM gasket). Swivel connection provides union between heat pump and piping system. The hoses feature brass fittings, stainless steel ferrules. A full port ball valve shall be provided with integral P/T (pressure/temperature) port on supply hose.

Specifications:

- Temperature range of 35°F [2°C] to 180°F [82°C].
- Max. working pressure of 400 psi [2757 kPa] for 1/2 in. and 3/4 in. hose kits; max. working pressure of 350 psi [kPa] for 1 in. and 1-1/4 in. hose kits.

Hose Kits - Automatic Balancing and Ball Valves (field-installed)

A flexible steel braid hose featuring Kevlar[®] reinforced EPDM core with ANSI 302/304 stainless steel outer braid and fire rated materials per ASTM E 84-00 (NFPA 255, ANSI/UL 723 & UBC 8-1). Ball valve at one end; swivel connector with adapter at the other end (swivel to adapter connection via fiber or EPDM gasket). Swivel connection provides union between heat pump and piping system. The hoses feature brass fittings, stainless steel ferrules. A full port ball valve shall be provided with integral P/T (pressure/temperature) port on supply hose and automatic balancing valve with integral P/T ports and full port ball valve on return hose.

Specifications:

- Temperature range of 35°F [2°C] to 180°F [82°C]
- Max. working pressure of 400 psi [2757 kPa] for 1/2 in. and 3/4 in. hose kits; max. working pressure of 350 psi [2413 kPa] for 1 in. and 1-1/4 in. hose kits
- Minimum burst pressure of four times working pressure

Hose Kits - Automatic Balancing and Ball Valves with 'Y' strainer (field-installed)

A flexible steel braid hose featuring Kevlar[®] reinforced EPDM core with ANSI 302/304 stainless steel outer braid and fire rated materials per ASTM E 84-00 (NFPA 255, ANSI/UL 723 & UBC 8-1). Ball valve at one end; swivel connector with adapter at the other end (swivel to adapter connection via fiber or EPDM gasket). Swivel connection provides union between heat pump and piping system. The hoses feature brass fittings, stainless steel ferrules. A "y" strainer is provided on one end for fluid straining and integral "blowdown" valve. A full port ball valve shall be provided with integral P/T (pressure/temperature) port on supply hose and automatic balancing valve with integral P/T ports and full port ball valve on return hose.

Specifications:

- Temperature range of 35°F [2°C] to 180°F [82°C]
- Max. working pressure of 400 psi [2756 kPa] for 1/2 in. and 3/4 in. hose kits; max. working pressure of 350 psi [2413 kPa] for 1 in. and 1-1/4 in. hose kits
- Minimum burst pressure of four times working pressure

Hot Water Pump Kit (field-installed)

An accessory pump kit is available for hot water generation option. This kit includes hot water pump, fittings, and water heater kit necessary for potable water application. Order DPK5 for use with Aurora and FX10 controls.

Notes

Revision Guide

Pages:	Description:	Date:	By:
All	Updated with New All-Aluminum Air Coils	19 May 2014	DS
19-27	Updated with New Aurora UPC DDC Controls	19 May 2014	DS
46 - 48	Updated Compressor LRA with IntelliStart	02 Aug 2013	DS
All	Updated Nomenclature to Reflect New Variable Speed ECM Motor	08 Jan 2013	DS
All	Added IntelliStart Availability for 3-Phase Units	08 Jan 2013	DS
15-18	Updated Aurora Controls Description	08 Jan 2013	DS
85	Replaced Wiring Diagram with Reheat Version	08 Jan 2013	DS
91	Added Revision Guide	08 Jan 2013	DS



Manufactured by
WaterFurnace International, Inc.
9000 Conservation Way
Fort Wayne, IN 46809
www.waterfurnace.com

Product: **Envision² Compact**
Type: Water Source/Geothermal Heat Pump
Size: Commercial 0.75-6 Ton
Document: Specification Catalog

SC1022ANA 05/14