

ENVISION™

Geothermal Hydronic Heat Pump
1.5 to 6 Tons

Installation Information

Water Piping Connections

Electrical Data

Startup Procedures

Preventive Maintenance



Table of Contents

- Model Nomenclature 4-5
- General Installation Information 6
- Water Quality 7
- Field Connected Water Piping 8-9
- Potable Water Systems. 10-11
- Hydronic Section 12-13
- Accessories and Options 14-15
- Electrical Data 16-17
- Wiring Schematics. 18-25
- External Control. 26-27
- Converting to a Dedicated Cooling Unit 28
- Unit Startup 29
- Standard Board - Control Features. 30-31
- Standard Control - Panel Configuration. 32-33
- Optional Controls 34-38
- AHRI/ISO 13256-2 Performance Ratings 39
- Pressure Drop. 39
- Operating Limits 40
- Physical Data 40
- Flow Rates 41
- Troubleshooting. 42-43
- Operating Parameters. 44
- Heating and Cooling Cycle Analysis. 45
- Troubleshooting Form 46
- Reference Calculations. 47
- Legend and Notes 47
- Antifreeze Correction 48
- Preventive Maintenance 49
- Service Parts. 50

Model Nomenclature - Residential (silver cabinet)

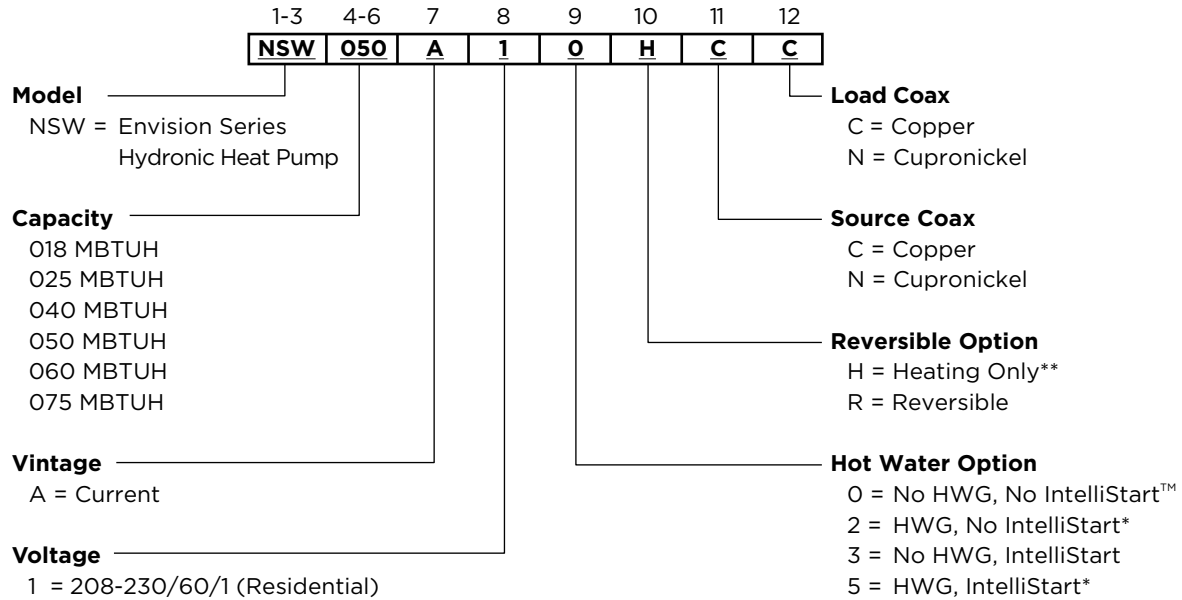

NOTES: *Available on 040, 050, 060, and 075 only. HWG requires field installed external pump kit.
 **NSW018 and NSW025 heating only models are available only with copper double wall vented load coax for potable water.

Model Nomenclature - Commercial (white cabinet)

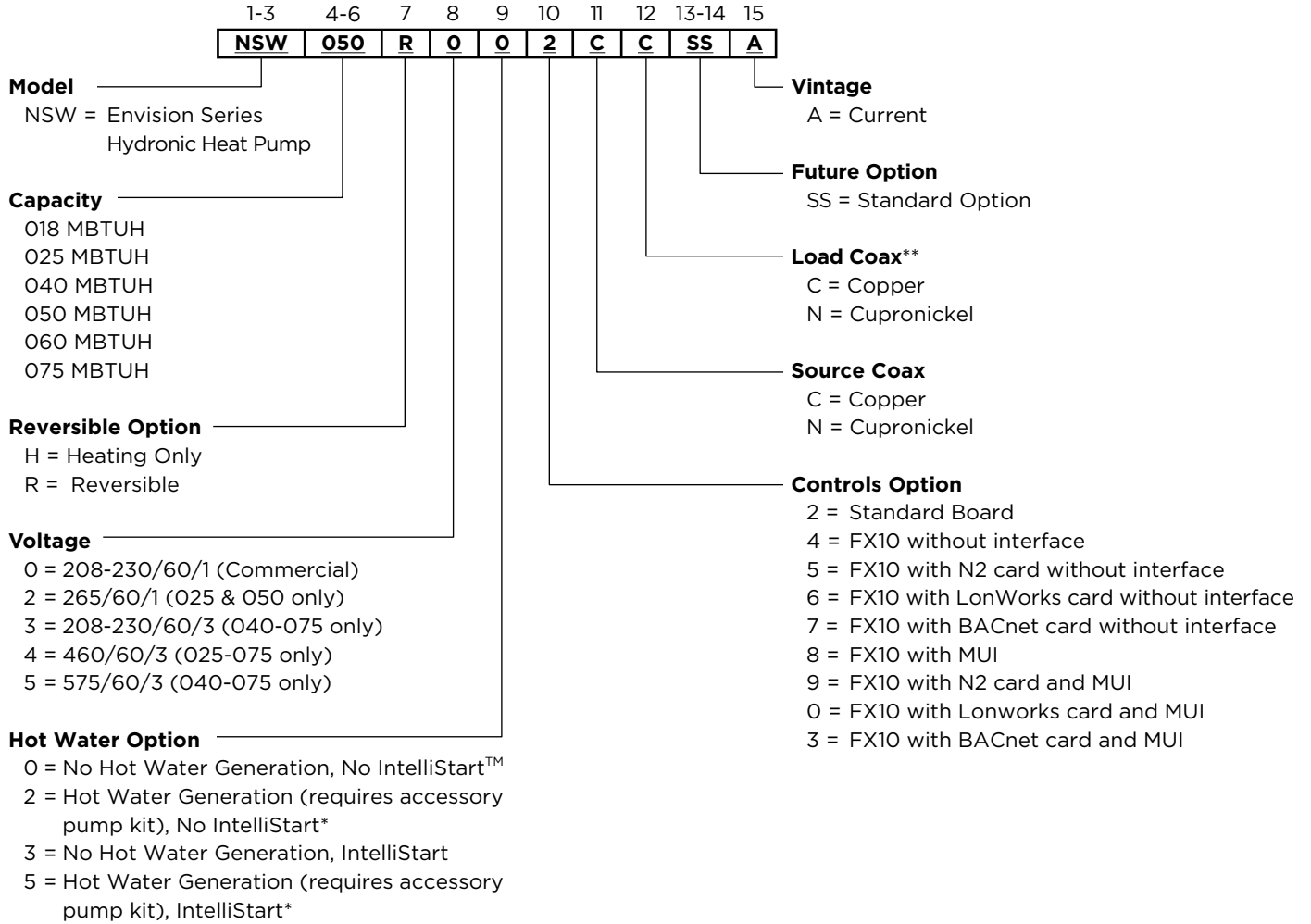

NOTES: *Available on 040, 050, 060, and 075 only. HWG requires field installed external pump kit.
**NSW018 and NSW025 heating only models are available only with copper double wall vented load coax for potable water.

General Installation Information

Safety Considerations

Installing and servicing air conditioning and heating equipment can be hazardous due to system pressure and electrical components. Only trained and qualified service personnel should install, repair or service heating and air conditioning equipment. When working on heating and air conditioning equipment, observe precautions in the literature, tags and labels attached to the unit and other safety precautions that may apply.

Follow all safety codes. Wear safety glasses and work gloves. Use quenching cloth for brazing operations. Have fire extinguisher available for all brazing operations.

NOTE: Before installing, check voltage of unit(s) to ensure proper voltage.



WARNING: Before performing service or maintenance operations on the system, turn off main power switches to the unit. Electrical shock could cause serious personal injury.

Process Water Applications

For process water applications, it is recommended that a secondary load heat exchanger be installed to prevent corrosion to the unit's primary coaxial coil. In situations where scaling could be heavy or where biological growth such as iron bacteria will be present, a closed loop system is recommended. Over a period of time, ground water unit heat exchanger coils may lose heat exchange capability due to a buildup of mineral deposits. These can be cleaned only by a qualified service mechanic as special pumping equipment and solutions are required. Never use flexible hoses with a smaller inside diameter than that of water connections.

Moving and Storage

Move units in the normal "Up" orientation as indicated by the labels on the unit packaging. When the equipment is received, all items should be carefully checked against the bill of lading to ensure that all crates and cartons have been received in good condition. Examine units for shipping damage, removing unit packaging if necessary to properly inspect unit. Units in question should also be internally inspected. If any damage is observed, the carrier should make the proper notation on delivery receipt acknowledging the damage. Units are to be stored in a location that provides adequate protection from dirt, debris and moisture.



WARNING: To avoid equipment damage, do not leave the system filled in a building without heat during cold weather, unless adequate freeze protection levels of antifreeze are used. Heat exchangers do not fully drain and will freeze unless protected, causing permanent damage.

Unit Location

Provide sufficient room to make water and electrical connections. If the unit is located in a confined space, provisions must be made for unit servicing. Locate the unit in an indoor area that allows easy removal of the access panels and has enough space for service personnel to perform maintenance or repair. These units are not approved for outdoor installation and, therefore, must be installed inside the structure being conditioned. Do not locate units in areas subject to freezing conditions.



WARNING: Do not store or install units in corrosive environments or in locations subject to temperature or humidity extremes (e.g. attics, garages, rooftops, etc.). Corrosive conditions and high temperature or humidity can significantly reduce performance, reliability, and service life.

Mounting Units

Units should be mounted level on a vibration absorbing pad slightly larger than the base to provide isolation between the unit and the floor. It is not necessary to anchor the unit to the floor. Allow access to the front, back, and side access panels for servicing.

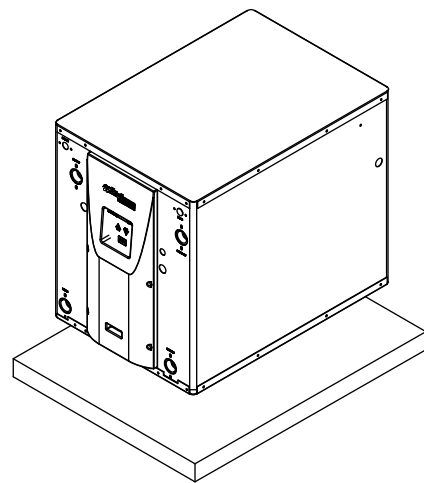

Vibration Pad Mounting

Water Quality

General

NSW water-to-water heat pumps may be successfully applied in a wide range of residential and light commercial applications. It is the responsibility of the system designer and installing contractor to ensure that acceptable water quality is present and that all applicable codes have been met in these installations.

Water Treatment

Do not use untreated or improperly treated water. Equipment damage may occur. The use of improperly treated or untreated water in this equipment may result in scaling, erosion, corrosion, algae or slime. The services of a qualified water treatment specialist should be engaged to determine what treatment, if any, is required. The product warranty specifically excludes liability for corrosion, erosion or deterioration of equipment.

The heat exchangers and water lines in the units are copper or cupronickel tube. There may be other materials in the building's piping system that the designer may need to take into consideration when deciding the parameters of the water quality.

If an antifreeze or water treatment solution is to be used, the designer should confirm it does not have a detrimental effect on the materials in the system.

Contaminated Water

In applications where the water quality cannot be held to prescribed limits, the use of a secondary or intermediate heat exchanger is recommended to separate the unit from the contaminated water.

The following table outlines the water quality guidelines for unit heat exchangers. If these conditions are exceeded, a secondary heat exchanger is required. Failure to supply a secondary heat exchanger where needed will result in a warranty exclusion for primary heat exchanger corrosion or failure.

Water Quality Guidelines

| Material | | Copper | 90/10 Cupro-Nickel | 316 Stainless Steel |
|-------------------------------------|--|--|--|--|
| pH | Acidity/Alkalinity | 7- 9 | 7 - 9 | 7 - 9 |
| Scaling | Calcium and Magnesium Carbonate | (Total Hardness) less than 350 ppm | (Total Hardness) less than 350 ppm | (Total Hardness) less than 350 ppm |
| Corrosion | Hydrogen Sulfide | Less than .5 ppm (rotten egg smell appears at 0.5 PPM) | 10 - 50 ppm | Less than 1 ppm |
| | Sulfates | Less than 125 ppm | Less than 125 ppm | Less than 200 ppm |
| | Chlorine | Less than .5 ppm | Less than .5 ppm | Less than .5 ppm |
| | Chlorides | Less than 20 ppm | Less than 125 ppm | Less than 300 ppm |
| | Carbon Dioxide | Less than 50 ppm | 10 - 50 ppm | 10- 50 ppm |
| | Ammonia | Less than 2 ppm | Less than 2 ppm | Less than 20 ppm |
| | Ammonia Chloride | Less than .5 ppm | Less than .5 ppm | Less than .5 ppm |
| | Ammonia Nitrate | Less than .5 ppm | Less than .5 ppm | Less than .5 ppm |
| | Ammonia Hydroxide | Less than .5 ppm | Less than .5 ppm | Less than .5 ppm |
| | Ammonia Sulfate | Less than .5 ppm | Less than .5 ppm | Less than .5 ppm |
| | Total Dissolved Solids (TDS) | Less than 1000 ppm | 1000-1500 ppm | 1000-1500 ppm |
| | LSI Index | +0.5 to -.05 | +0.5 to -.05 | +0.5 to -.05 |
| Iron Fouling (Biological Growth) | Iron, Fe ²⁺ (Ferrous) Bacterial Iron Potential | < .2 ppm | < .2 ppm | < .2 ppm |
| | Iron Oxide | Less than 1 ppm. Above this level deposition will occur. | Less than 1 ppm. Above this level deposition will occur. | Less than 1 ppm. Above this level deposition will occur. |
| Erosion | Suspended Solids | Less than 10 ppm and filtered for max of 600 micron size | Less than 10 ppm and filtered for max of 600 micron size | Less than 10 ppm and filtered for max of 600 micron size |
| | Threshold Velocity (Fresh Water) | < 6 ft/sec | < 6 ft/sec | < 6 ft/sec |

Grains = PPM divided by 17 • mg/l is equivalent to PPM

2/8/08

Field Connected Water Piping

General

Each unit is equipped with captive FPT water connections to eliminate 'egg-shaping' from use of a backup wrench. For making the water connections to the unit, a Teflon tape thread sealant is recommended to minimize internal fouling of the piping. Do not over tighten connections. All supply and return water piping should be insulated to prevent excess condensation from forming on the water lines.

NOTE: Units are factory run-tested using propylene glycol. Prior to connecting piping to unit, thoroughly flush heat exchangers.

The piping installation should provide service personnel with the ability to measure water temperatures and pressures. The water lines should be routed so as not to interfere with access to the unit. The use of a short length of high pressure hose with a swivel type fitting may simplify the connections and prevent vibration. Optional stainless steel hose kits are available as an accessory item.

Before final connection to the unit, the supply and return hose kits must be connected, and the system flushed to remove dirt, piping chips and other foreign material. Normally, a combination balancing and close-off (ball) valve is installed at the return, and a rated gate or ball valve is installed at the supply. The return valve can be adjusted to obtain the proper water flow. The valves allow the unit to be removed for servicing.

The proper water flow must be delivered to each unit whenever the unit heats or cools. To assure proper flow, the use of pressure/temperature ports is recommended to determine the flow rate. These ports should be located adjacent to the supply and return connections on the unit. The proper flow rate cannot be accurately set without measuring the water pressure drop through the refrigerant-

Typical Open Loop Installation

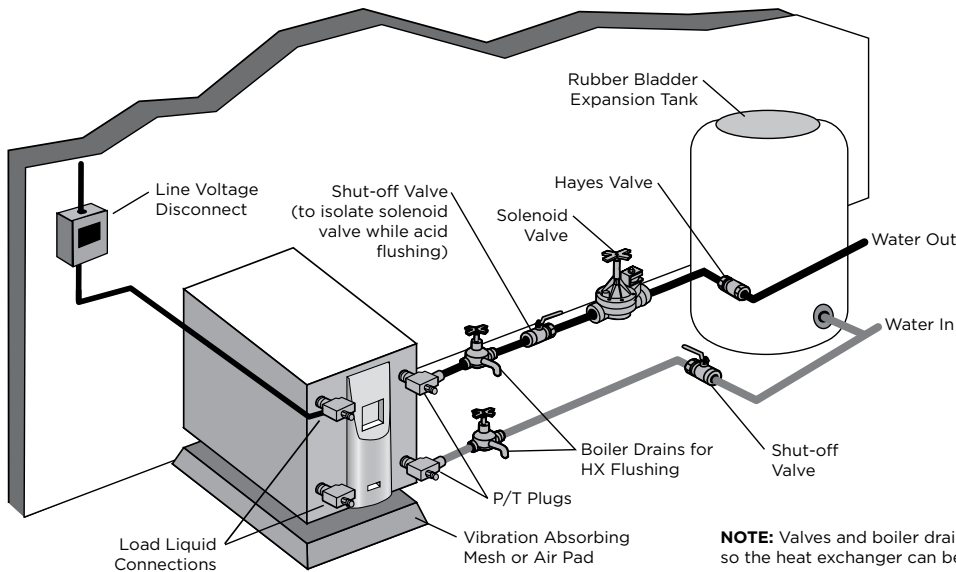

to-water heat exchanger (See Pressure Drop Table for water flow and pressure drop information). Normally about 3 GPM flow rate per ton of cooling capacity (2.25 GPM per ton minimum) is needed. Both source as well as load fluid piping must be at least as large as the unit connections on the heat pump (larger on long runs).

Never use flexible hoses of a smaller inside diameter than that of the water connection on the unit and limit hose length to 10 ft. per connection. Check carefully for water leaks.



CAUTION: Water piping exposed to outside temperature may be subject to freezing.

Open Loop Well Water Systems

Always maintain water pressure in the heat exchanger by placing water control valves at the outlet of the unit. Use a closed bladder type expansion tank to minimize mineral deposits. Ensure proper water flow through the unit by checking pressure drop across the heat exchanger and comparing it to the figures in the pressure drop table. Normally, about 2 GPM flow rate per ton of cooling capacity is needed in open loop systems, (1.5 GPM per ton minimum if entering source temperature is above 50°F [10°C]).

Some water control valves draw their power directly from the unit's 24V transformer and can overload and possibly burn out the transformer. Check total VA draw of the water valve(s) and ensure it is under 40 VA.

Discharge water from a heat pump can be disposed of in various ways depending on local building codes (i.e. recharge well, storm sewer, drain field, adjacent stream or pond, etc.). Most local codes restrict the use of sanitary sewer for disposal. Consult your local building and zoning departments to ensure compliance in your area.

NOTE: Valves and boiler drains must be installed so the heat exchanger can be acid flushed.

Field Connected Water Piping cont.

Earth Coupled Systems with Flow Center

Once piping is completed between the unit, flow center and the earth loop, final purging and charging of the loop is needed. A flush cart (at least a 1.5 HP or 1.12 kW pump) is needed to achieve adequate flow velocity in the loop to purge air and dirt particles from the loop itself. Antifreeze solution is used in most areas to prevent freezing. Maintain the pH in the 7.6-8.2 range for final charging.

Flush the system adequately to remove as much air as possible. Then, pressurize the loop to a static pressure of 50-75 psi [345-517 kPa]. This is normally adequate for good system operation. Ensure that the flow center provides adequate flow through the unit by checking pressure drop across the heat exchanger and by comparing it to the figures shown in the Pressure Drop tables. Usually, 3 GPM/ton [0.054 L/s/kW] L/s/kW or minimum 2.25 GPM/ton [0.04 L/s/kW] of cooling capacity is needed in closed loop earth-coupled applications

Typical Closed Loop Earth Coupled Installation

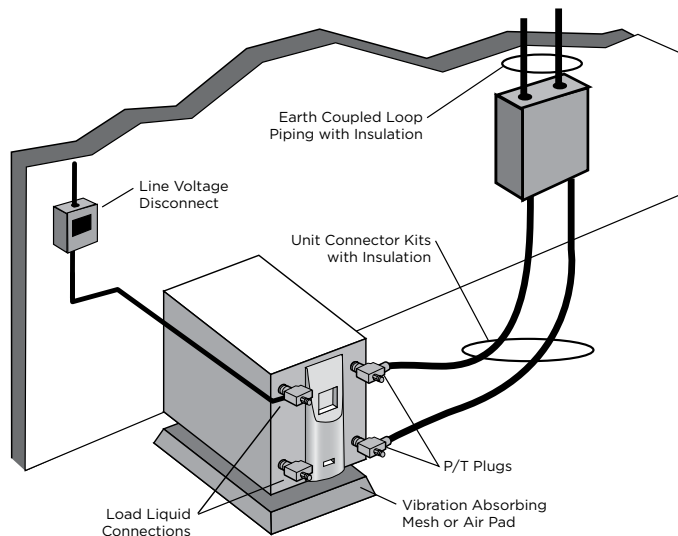

Potable Water Systems

The NSW018 and NSW025 models can be equipped to provide domestic hot water generation. An optional factory-installed hot water generator coil may be provided with the NSW040, NSW050, NSW060, and NSW075 to assist with this process.

Suggested Domestic Water Heater Hookup

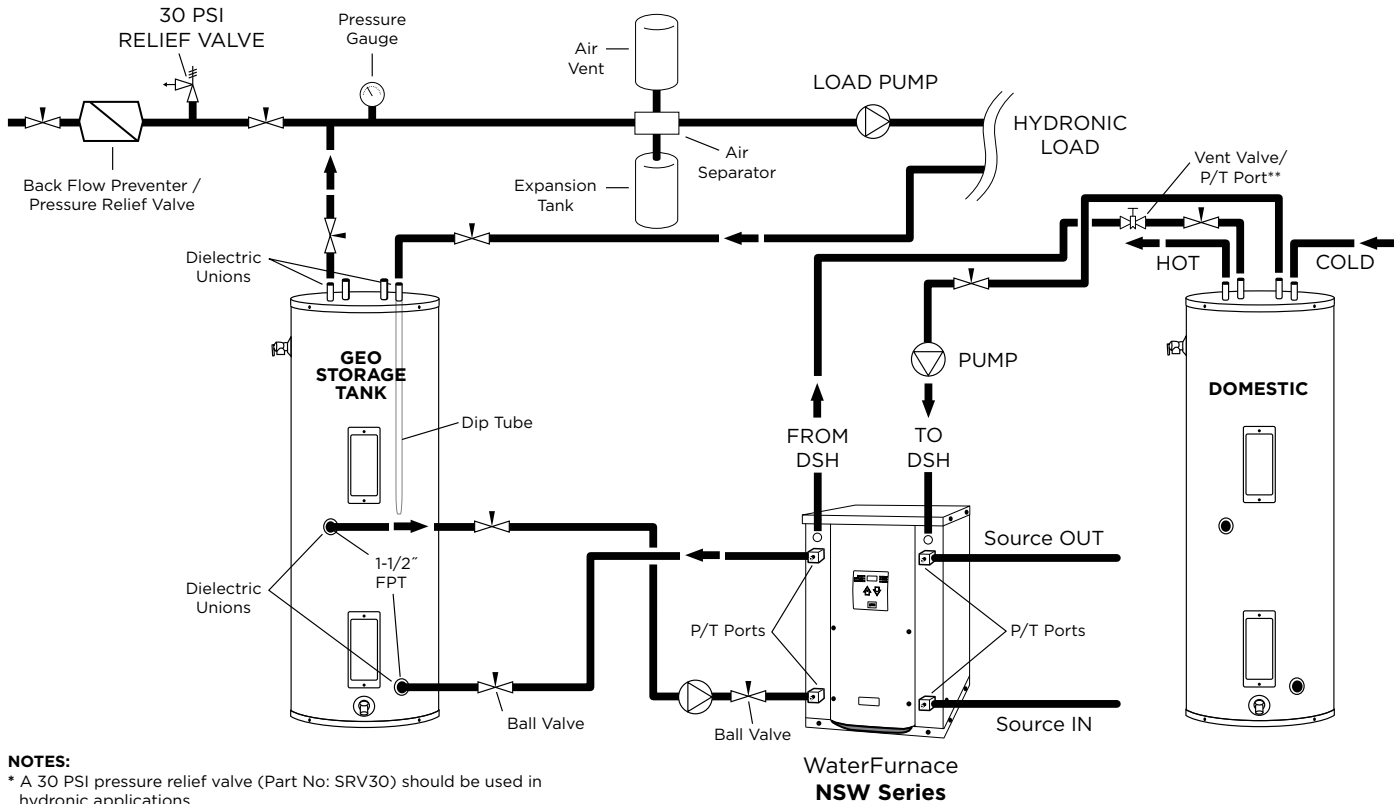

- NOTES:**
- * A 30 PSI pressure relief valve (Part No: SRV30) should be used in hydronic applications.
 - ** Vent valve or P/T port at highest point in return line prior to ball valve.

NOTES:

- 1) Unions and valves must be installed so that acid flushing of the heat exchanger is possible.
- 2) Route thermistor wires to NSW. Remove yellow thermistor wires on TB 3 and 4 from control box and connect thermistor wires from geothermal storage tank. Set the pump sampling (PS) in the set up of the control board to continuously (C) sampling (reference Note 5 in the Wiring Schematic).

Hot Water Generator Connections

To maximize the benefits of the hot water generator a minimum 50-gallon water heater is recommended. For higher demand applications, use an 80-gallon water heater as shown below or two 50-gallon water heaters connected in a series. Electric water heaters are recommended. Make sure all local electrical and plumbing codes are met for installing a hot water generator. The Envision NSW is not supplied with an internal circulator. A DPK5 kit will need to be purchased to connect to the hot water generator. The DPK5 kit is supplied with installation instructions, circulator, tank adaptor and temperature limit switch. Be sure to burp (vent) the pump. Open the screw 2 turns only in the end of the pump motor (if Grundfos® pumps are used) to allow trapped air to be discharged and to ensure the motor housing has been flooded.

Potable Water Systems cont.

Alternate Hot Water Installation with Direct Coupling to a Double Wall Unit

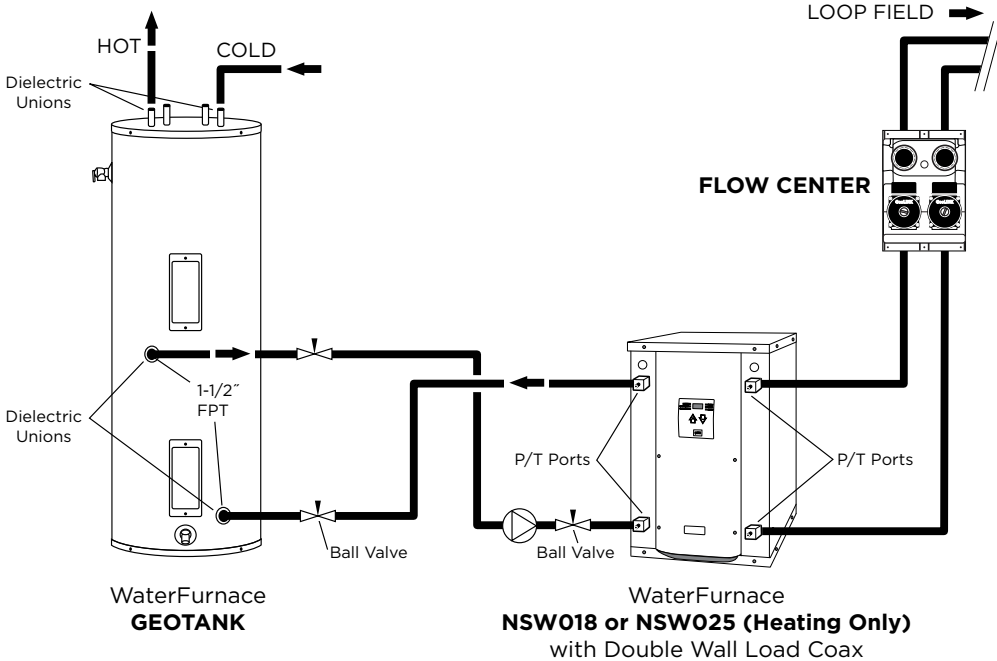

NOTES:

- 1) Unions and valves must be installed so that acid flushing of the heat exchanger is possible.
- 2) Make sure there is not a check valve in the diptube of the tank.
- 3) Route thermistor wires to NSW. Remove yellow thermistor wires on TB 3 and 4 from control box and connect thermistor wires from geothermal storage tank. Set the pump sampling (PS) in the set up of the control board to continuously (C) sampling (reference Note 5 in the Wiring Schematic).

Hydronic Section

General guidelines are shown below for component selection and design/installation criteria for the piping system. Local codes supersede any recommendations in this manual.

Shut Off/Flow Regulation Valves

Use full port ball valves or gate valves for component isolation. If valves are going to be used frequently, ball valves are recommended. Globe valves are designed for flow regulation. Always install globe valves in the correct direction (fluid should enter through the lower body chamber).

Check valves

Swing check valves must be installed in the horizontal position with the bonnet of the valve upright. Spring check valves can be mounted in any position. A flow check valve is required to prevent thermo-siphoning (or gravity flow) when the circulator pump is off or when there are two circulators on the same system.

Storage (Buffer) Tank

A buffer tank is required for all hydronic heating systems using Envision NSW heat pumps. The tank should be sized to provide 2 gallons of storage capacity for every one thousand Btuh's of nominal heat pump capacity.

Pressure Relief Valve

Most codes require the use of a pressure relief valve if a closed loop heat source can be isolated by valves. Even if local code does not require this device, WaterFurnace recommends its installation. If the pressure relief valve in the buffer tank is not already rated at 30 psi (207 kPa) maximum pressure, one must be installed. The pressure relief valve should be tested at start up for operation. Note that the waste pipe must be at least the same diameter as the valve outlet (never reduce), and valves may not be added to this pipe. The bottom of the pipe must terminate at least 6" (15 cm) above the floor. If the piping is connected to a drain, there must be an air gap.

Backflow Prevention Check Valves

Most codes require backflow prevention check valves. Note that a single check valve is not equal to a backflow prevention check valve. Even if local code does not require this device, WaterFurnace recommends its installation. This is particularly important if the system will use antifreeze.

Pressure Reducing Valves or Feed Water Valves

This valve lowers the pressure from the make-up water line to the system. Most are adjustable and directional. A "fast fill" valve is required for initial filling of the system. Some have screens, which must be cleaned after the initial filling.

If there is a restriction in the screen, the system could go to 0 psi (0 kPa), potentially causing pumps(s) failure. A valve should be installed on each side of the pressure reducing valve for servicing. Both valves should have tags reading "Do not shut this valve under normal operation - service valve only."

Expansion Tanks

Expansion tanks are required on hydronic systems to help absorb the pressure swings as the temperature in the system fluctuates.

Elbows/Tees

Long radius elbows or two 45° elbows will lower pressure drop. Standard tees have a greater restriction on the "T" portion than tees designed with angled outlet ports.

Antifreeze

Antifreeze is required if any of the piping system is located in areas subject to freezing.

Dielectric Unions

Dielectric unions are recommended whenever connecting two dissimilar metals to one and other to prevent electro-galvanic corrosion.

When using the various types of hydronic heat distribution systems, the temperature limits of the geothermal system must be a major consideration. In new construction, the distribution system can easily be designed with the temperature limits in mind. In retrofits, care must be taken to address the operating temperature limits of the existing distribution system. The maximum storage tank temperature for the Envision NSW is 130°F (54.4°C). Typical in floor radiant systems require much lower temperatures, typically 100°-115°F, which is ideal for the Envision NSW.

Hydronic Section cont.

Open the screw 2 turns only in the end of the pump motor (if Grundfos® pumps are used) to allow trapped air to be discharged and to ensure the motor housing has been flooded.

Route thermistor wires to NSW. Remove yellow thermistor wires on TB 3 and 4 from control box and connect thermistor wires from geothermal storage tank. Set the pump sampling (PS) in the set up of the control board to continuously (C) sampling (reference Note 5 in the Wiring Schematic).

Adequate rate of flow (GPM) is very important to system performance and long term reliability. Follow the guidelines for recommended flow and pipe sizing in the NSW recommendations table.

WaterFurnace Geothermal Storage Tank Thermostat and Thermistor

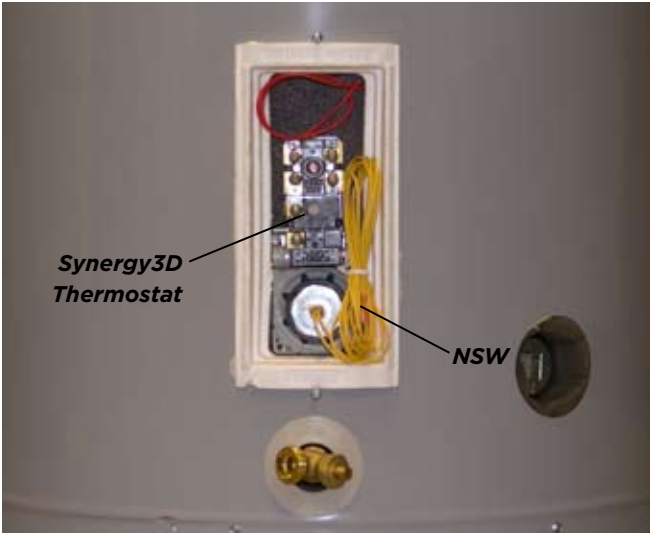

Yellow Thermistor Wires Connected to TB (3 and 4) on NSW Control Board

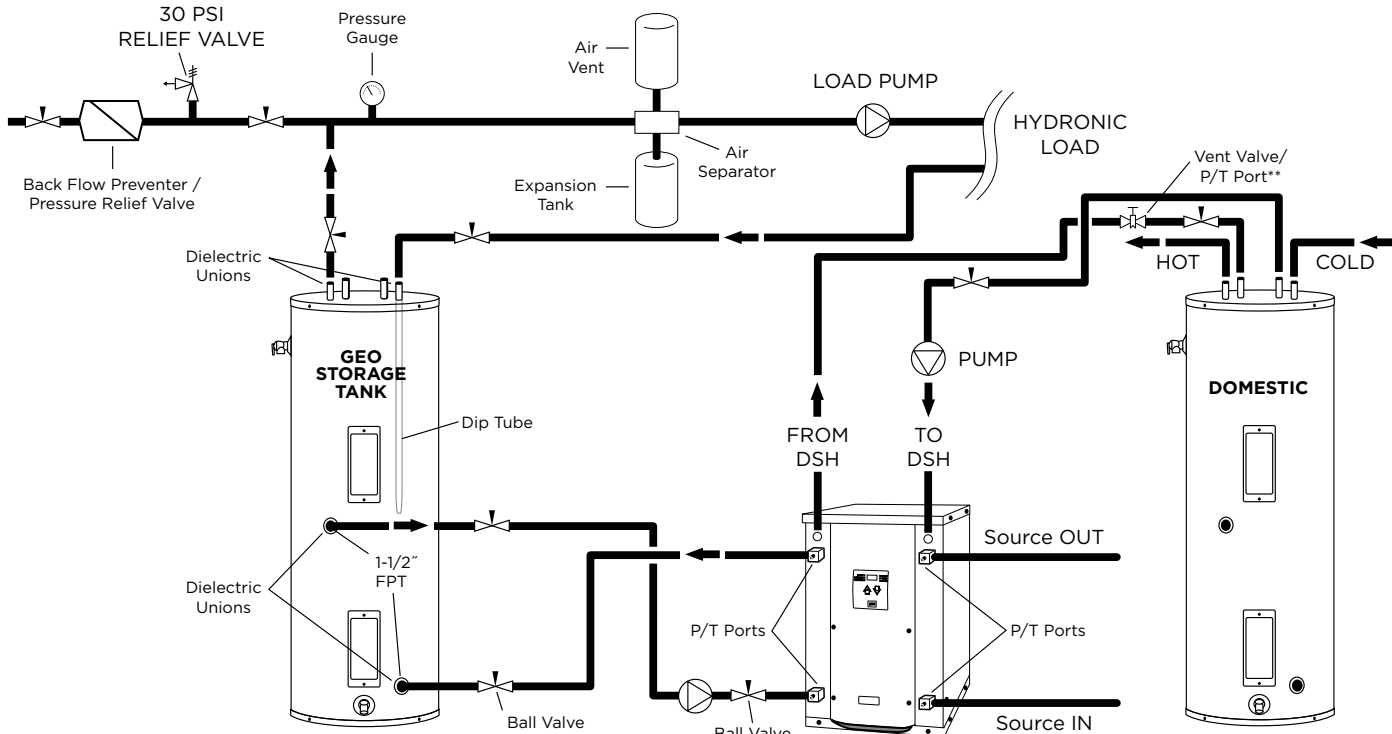

- NOTES:**
- * A 30 PSI pressure relief valve (Part No: SRV30) should be used in hydronic applications.
 - ** Vent valve or P/T port at highest point in return line prior to ball valve.

Accessories and Options

Water Connection Kits (Field Installed)

Water connection kits have been designed to facilitate load-side and loop-side water connections. See IM1470 for more information.

Earth Loop Pump Kit (Field Installed)

A specially designed one or two-pump module provides all liquid flow, fill and connection requirements for independent single unit systems (230/1/60 only). The one-pump module is capable of 20 feet of head at 16.0 GPM, while the two-pump module is capable of 40 feet of head at 16.0 GPM.

Hot Water Generator (Factory Installed, NSW040, NSW050, NSW060, and NSW075 Only)

An optional heat reclaiming hot water generator coil constructed of vented double-wall copper construction suitable for potable water is available. The coil is factory mounted inside the unit. A DPK5 pump kit is required (field installed), which includes a DHW tank connection and a temperature limit pump shutoff.

Load-side Pump Kit (Field Installed)

Four (4) load pump kits are available to provide all liquid flow requirements for independent single unit systems (230/1/60 only). WaterFurnace part number **24P501A04** (Grundfos UP15-42B7) and **EWPK2** (Grundfos UP26-64BF) are bronze body pumps. Bronze body pumps should be used when water conditions exist that are not compatible with cast iron or for applications such as domestic water heating. WaterFurnace part number **EWPK1** and **EWPK3** come with a cast iron body pump (Grundfos UP26-99F) that can be used for hydronic heating applications.

Calculate the system pressure drop then refer to the pump curves to select the proper pump. All four of the WaterFurnace pump kits can be used for hydronic heating applications as long as they meet the flow requirements. If the flow requirements are outside the pump curve, an alternate pump will need to be obtained to maintain the necessary flow.

IntelliStart™

The optional IntelliStart single phase soft starter will reduce the normal start current (LRA) by 60-70%. This allows the heat pump to go off-grid. Using IntelliStart also provides a substantial reduction in light flicker, reduces start-up noise, and improves the compressor's start behavior. IntelliStart is available in a field retrofit kit (WaterFurnace part number **IS60RKL** or **IS60RKS**) or as a factory installed option for all Envision and Synergy3D units.

Single Pump Curve: UP15-42B7, UP26-64BF, and UP26-99F

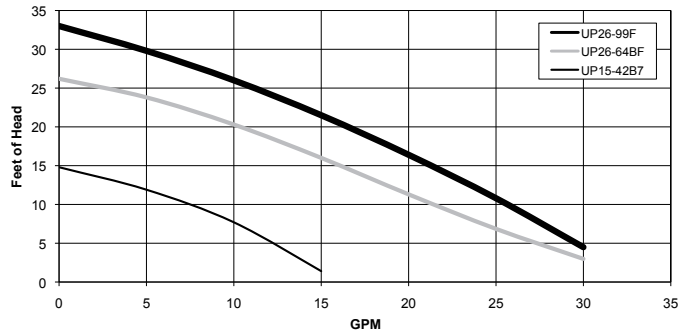

Two Pump Curve: UP26-64BF and UP26-99F

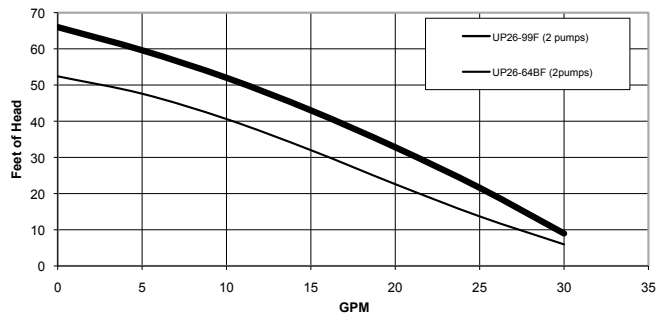

NOTE: Never use piping smaller than 1 inch. Limit length of pipe to 50 feet or less.

Type L Copper Pressure Loss
Ft of Hd per 100 ft

| GPM | Type L Copper Tube | | | | |
|-----|--------------------|-----|-------|-------|-----|
| | 3/4 | 1 | 1-1/4 | 1-1/2 | 2 |
| 2 | 1.5 | | | | |
| 3 | 3.2 | | | | |
| 4 | 5.5 | 1.4 | | | |
| 5 | 8.5 | 2.1 | | | |
| 6 | | 2.9 | 1.1 | | |
| 7 | | 3.9 | 1.4 | | |
| 8 | | 5.0 | 1.8 | | |
| 9 | | 6.1 | 2.3 | 0.9 | |
| 10 | | 7.5 | 2.8 | 1.1 | |
| 12 | | | 3.9 | 1.6 | |
| 14 | | | 5.2 | 2.1 | |
| 16 | | | 6.6 | 2.7 | |
| 18 | | | 8.2 | 3.4 | |
| 20 | | | 10.0 | 4.1 | 1.1 |
| 22 | | | | 5.0 | 1.3 |
| 25 | | | | 6.3 | 1.6 |
| 30 | | | | | 2.2 |
| 35 | | | | | 2.9 |
| 40 | | | | | 3.8 |
| 45 | | | | | 4.7 |
| 50 | | | | | 5.7 |

NOTE: Standard piping practice limits pressure drop to 4 feet of hd per 100 feet in 2 inch and larger pipe.

Accessories and Options cont.

Geo Storage Tank Dimensions

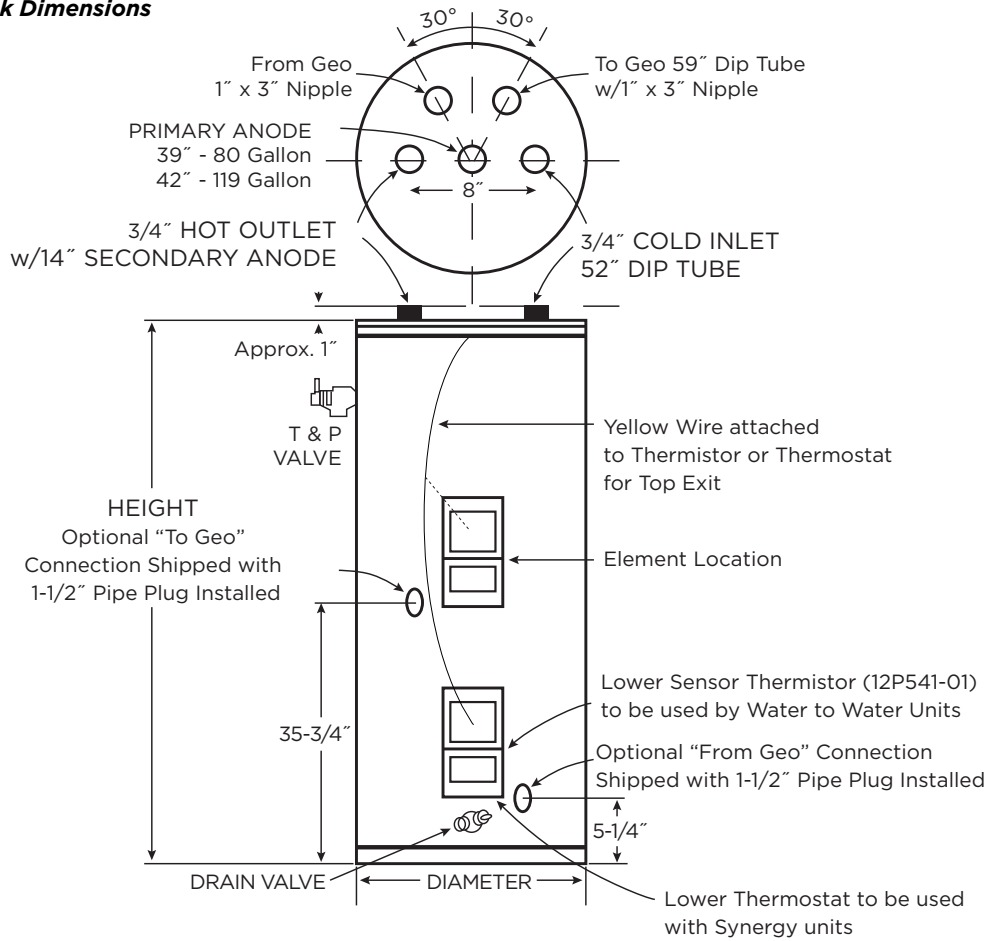

| MODEL NUMBER | GALLON CAPACITY | ELEMENT WATTAGE (240 VOLT) | NUMBER OF ELEMENTS | R VALUE | DIMENSIONS IN INCHES | | APPROX. SHIPPING WEIGHT (lbs.) |
|-----------------|-----------------|----------------------------|--------------------|---------|----------------------|----------|--------------------------------|
| | | | | | HEIGHT | DIAMETER | |
| GEO-STORAGE-80 | 80 | 4500 | 1 | 16 | 63-1/4 | 24 | 204 |
| GEO-STORAGE-120 | 119 | 4500 | 1 | 16 | 63-1/4 | 28 | 311 |

Electrical Data

| Model | Rated Voltage | Voltage Min/Max | Compressor | | | Load Pump | Source Pump | Total Unit FLA | Min Ckt Amp | Maximum Fuse/HACR |
|-------|---------------|-----------------|------------|-------|------|-----------|-------------|----------------|-------------|-------------------|
| | | | RLA | LRA | LRA* | | | | | |
| 018 | 208-230/60/1 | 197/254 | 10.3 | 51.0 | 17.9 | 1.8 | 5.4 | 17.5 | 20.1 | 30 |
| 025 | 208-230/60/1 | 197/254 | 13.5 | 61.0 | 21.4 | 1.8 | 5.4 | 20.7 | 24.1 | 35 |
| | 265/60/1 | 239/292 | 10.9 | 58.0 | - | - | - | 10.9 | 13.6 | 20 |
| | 460/60/3 | 414/506 | 4.5 | 27.0 | - | - | - | 4.5 | 5.6 | 10 |
| 040 | 208-230/60/1 | 197/254 | 20.0 | 115.0 | 40.3 | 1.8 | 5.4 | 27.2 | 32.2 | 50 |
| | 208-230/60/3 | 197/254 | 12.8 | 95.0 | - | - | - | 12.8 | 16.0 | 25 |
| | 460/60/3 | 414/506 | 6.4 | 45.0 | - | - | - | 6.4 | 8.0 | 10 |
| | 575/60/3 | 518/632 | 5.4 | 38.0 | - | - | - | 5.4 | 6.8 | 10 |
| 050 | 208-230/60/1 | 197/254 | 26.4 | 134.0 | 46.9 | 1.8 | 5.4 | 33.6 | 40.2 | 60 |
| | 265/60/1 | 239/292 | 19.9 | 130.0 | - | - | - | 19.9 | 24.9 | 40 |
| | 208-230/60/3 | 197/254 | 16.0 | 110.0 | - | - | - | 16.0 | 20.0 | 35 |
| | 460/60/3 | 414/506 | 7.8 | 52.0 | - | - | - | 7.8 | 9.8 | 15 |
| | 575/60/3 | 518/632 | 5.7 | 38.9 | - | - | - | 5.7 | 7.1 | 10 |
| 060 | 208-230/60/1 | 197/254 | 30.1 | 145.0 | 50.8 | 1.8 | 5.4 | 37.3 | 44.8 | 70 |
| | 208-230/60/3 | 197/254 | 17.3 | 120.0 | - | - | - | 17.3 | 120.0 | 35 |
| | 460/60/3 | 414/506 | 9.6 | 70.0 | - | - | - | 9.6 | 70.0 | 20 |
| | 575/60/3 | 518/632 | 8.0 | 53.0 | - | - | - | 8.0 | 53.0 | 15 |
| 075 | 208-230/60/1 | 197/254 | 26.9 | 145.0 | 50.8 | 1.8 | 5.4 | 34.1 | 40.8 | 60 |
| | 208-230/60/3 | 197/254 | 22.4 | 190.0 | - | - | - | 22.4 | 28.0 | 50 |
| | 460/60/3 | 414/506 | 12.2 | 87.0 | - | - | - | 12.2 | 15.3 | 25 |
| | 575/60/3 | 518/632 | 9.6 | 62.0 | - | - | - | 9.6 | 12.0 | 20 |

NOTES: All fuses type "D" time delay (or HACR circuit breaker in USA).
 Source pump amps shown are for up to a 1/2 HP pump.
 Load pumps amps shown are for small circulators.
 *LRA with optional IntelliStart installed (208-230/1/60).

7/22/2009

NSW Control Box

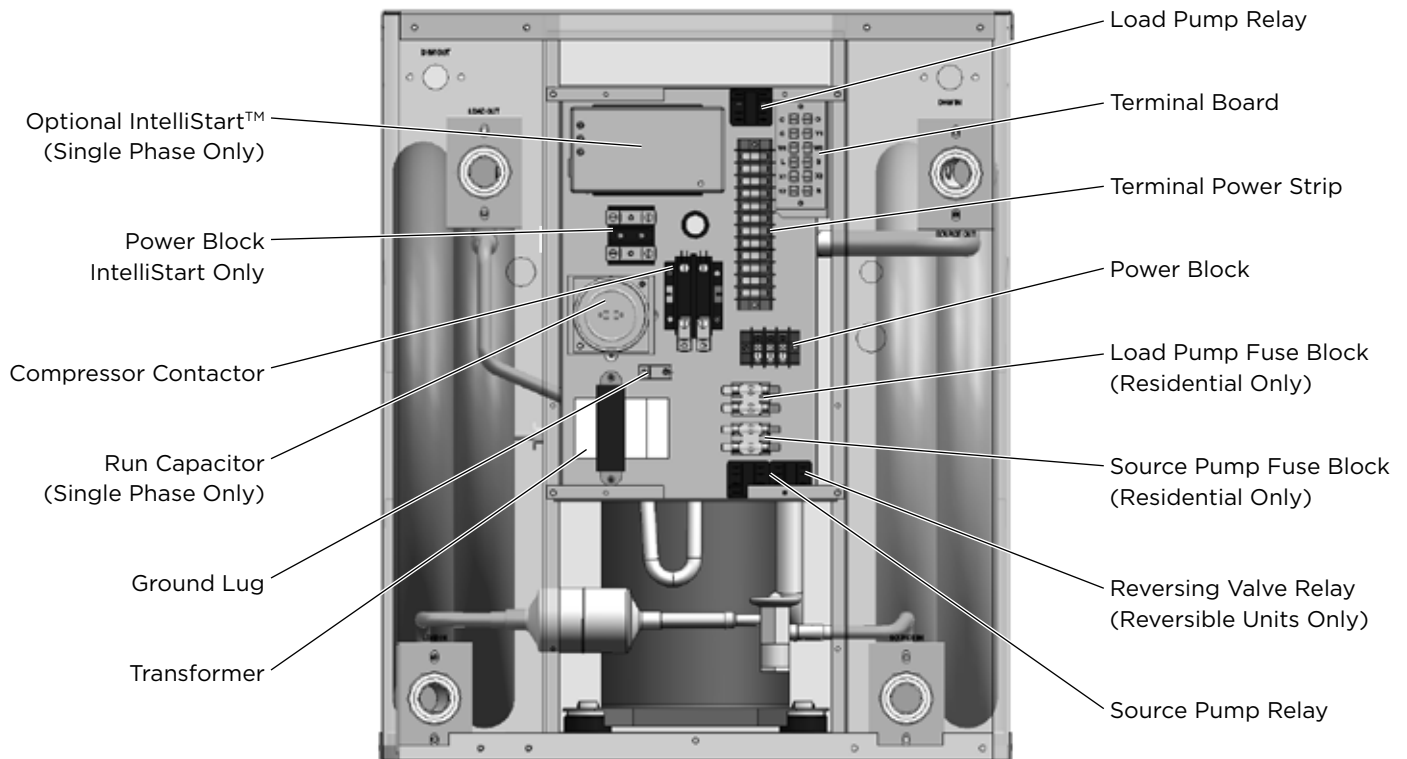

Electrical Data cont.

208 Volt Operation

All 208-230 volt units are factory wired for 230 volt operation. To convert the unit from a 230V unit to a 208V unit follow these steps:

1. Remove the blue transformer wire from terminal L2 on the compressor contactor and secure the wire taking care to insulate the end with electrical tape.
2. Locate the red transformer wire and connect it to the L2 terminal of the compressor contactor.

Electrical

Be sure the available power is the same voltage and phase as that shown on the unit serial plate. Line and low voltage wiring must be done in accordance with local codes or the National Electric Code, whichever is applicable. Refer to the Electrical Data table for wire and fuse or circuit breaker sizing information.

Flow Center Pump Connection (208-230/60/1)

Two fuse internal terminal block connections with 1/4-inch spade connectors are provided; one for the load pump and one for the source pump. The source pump directly connects to the fuse terminal block for the source pump. The load pump directly connects to the fuse terminal block for the load pump.

NSW Control Box Relocation

The NSW control box can be installed on the rear of the unit. To relocate the control box, follow the procedures below.

1. Remove all power sources to the unit.
2. Remove the unit's top panel.
3. Cut all plastic wire ties to the following:
 - a) High pressure switch (black wires)
 - b) Low pressure switch (blue wires)
 - c) Freeze sensing (yellow wires)
 - d) Load temperature sensor (black wires)
 - e) Compressor wires
4. Remove the four screws from the control box.
5. Relocate the control box to opposite end of the unit.
6. Using the screws removed in step 4 above, reattach the control box.
7. Secure all wires so they do not come in contact with refrigerant lines.
8. Replace the top of the unit.
9. Replace both access panels.
10. Reapply power sources.

NOTE: If geothermal storage tank is used, connect yellow thermistor wires from the bottom access panel of the tank to spade connectors 3 and 4 on the terminal block.

Wiring Schematics

For all NSW 208/230 volt single-phase units, the circulator wiring is as shown in the illustrations below. The internal relay and fusing allow for external pumps no larger than .5 horsepower. The external loop pump connections mentioned in this manual include a dedicated flow center for each unit as well as an NSW unit connected to an Envision; “P” or an “E” series unit containing a microprocessor.

Load Circulator Wiring

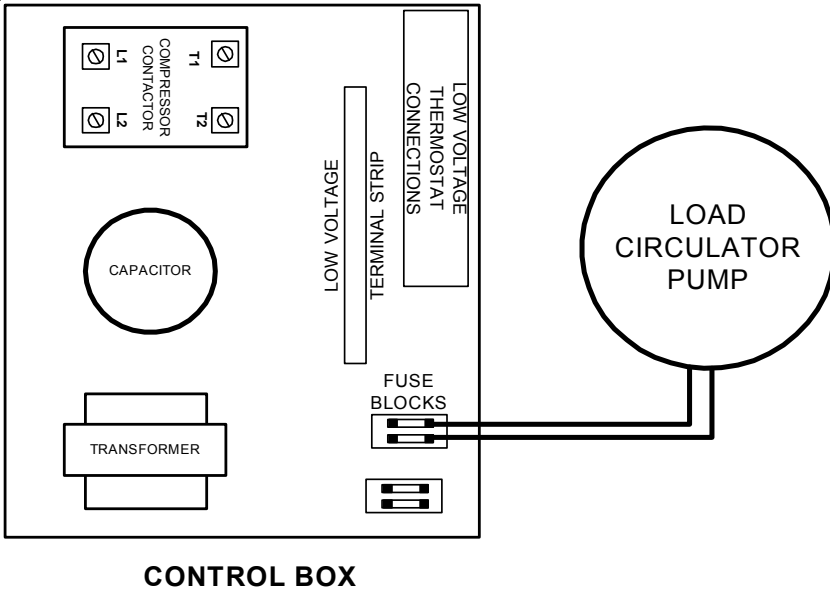

Dedicated Flow Center Wiring

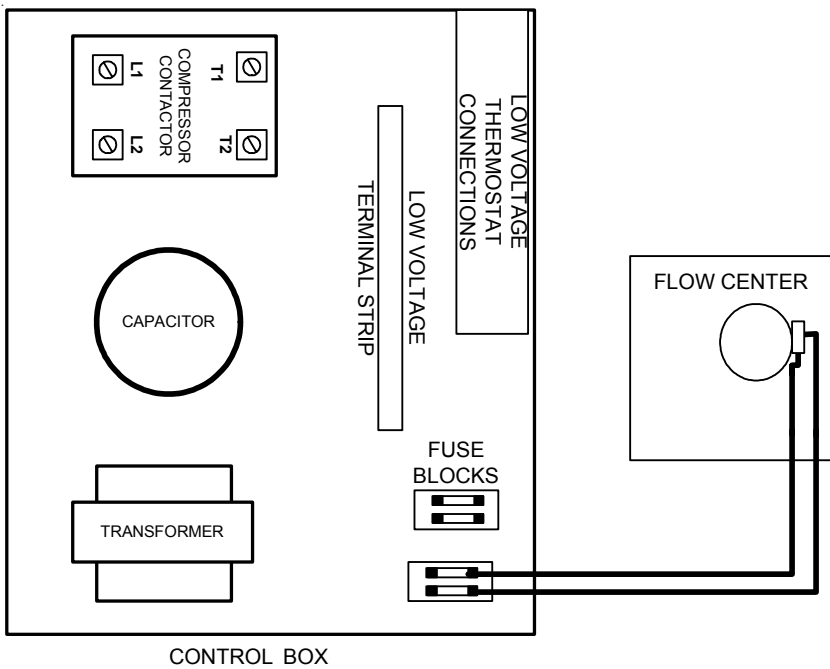

Wiring Schematics cont.

Multiple Units on a Single Flow Center Wiring

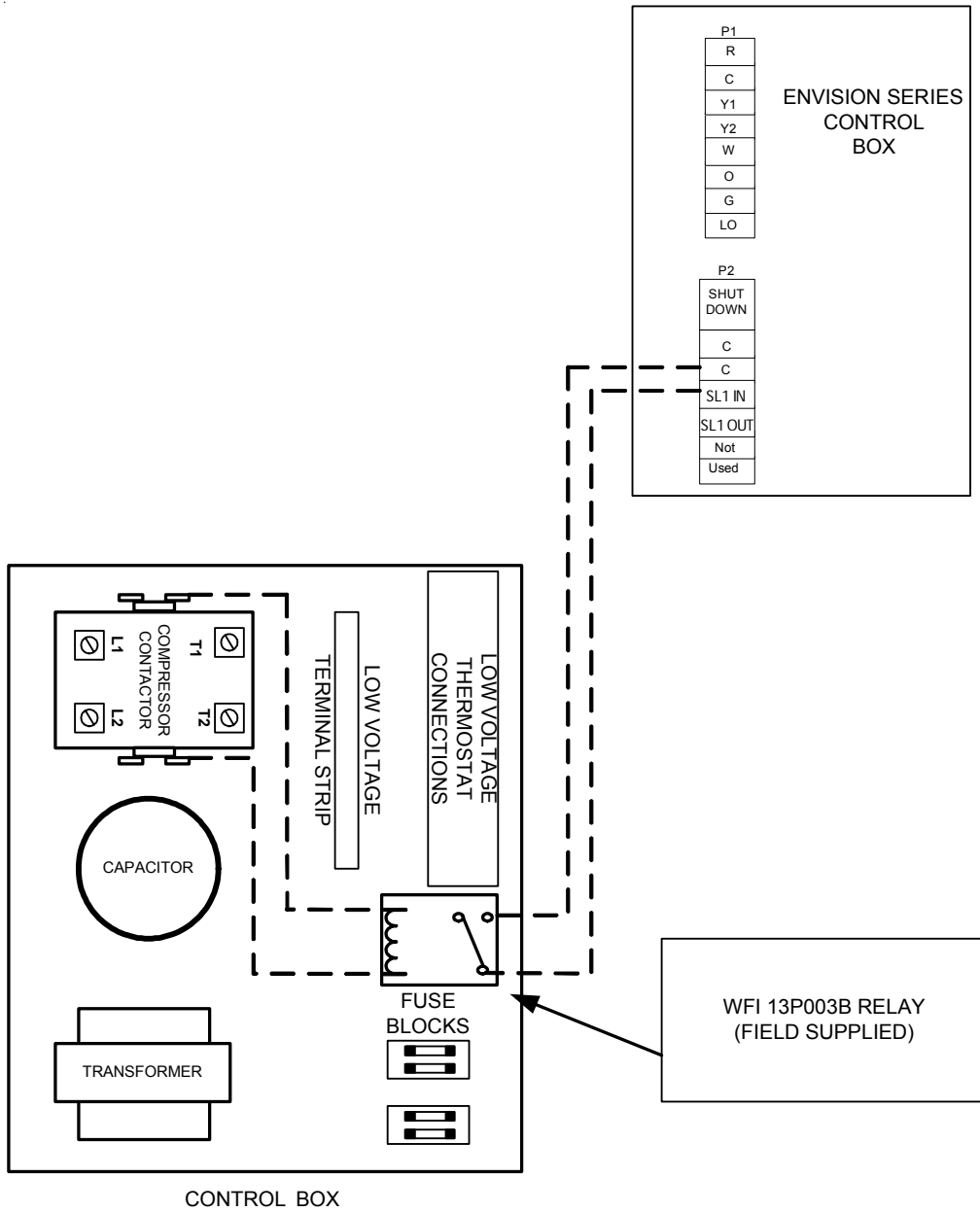

Wiring Schematics - Residential

NSW Heating Only - 208-230/60/1

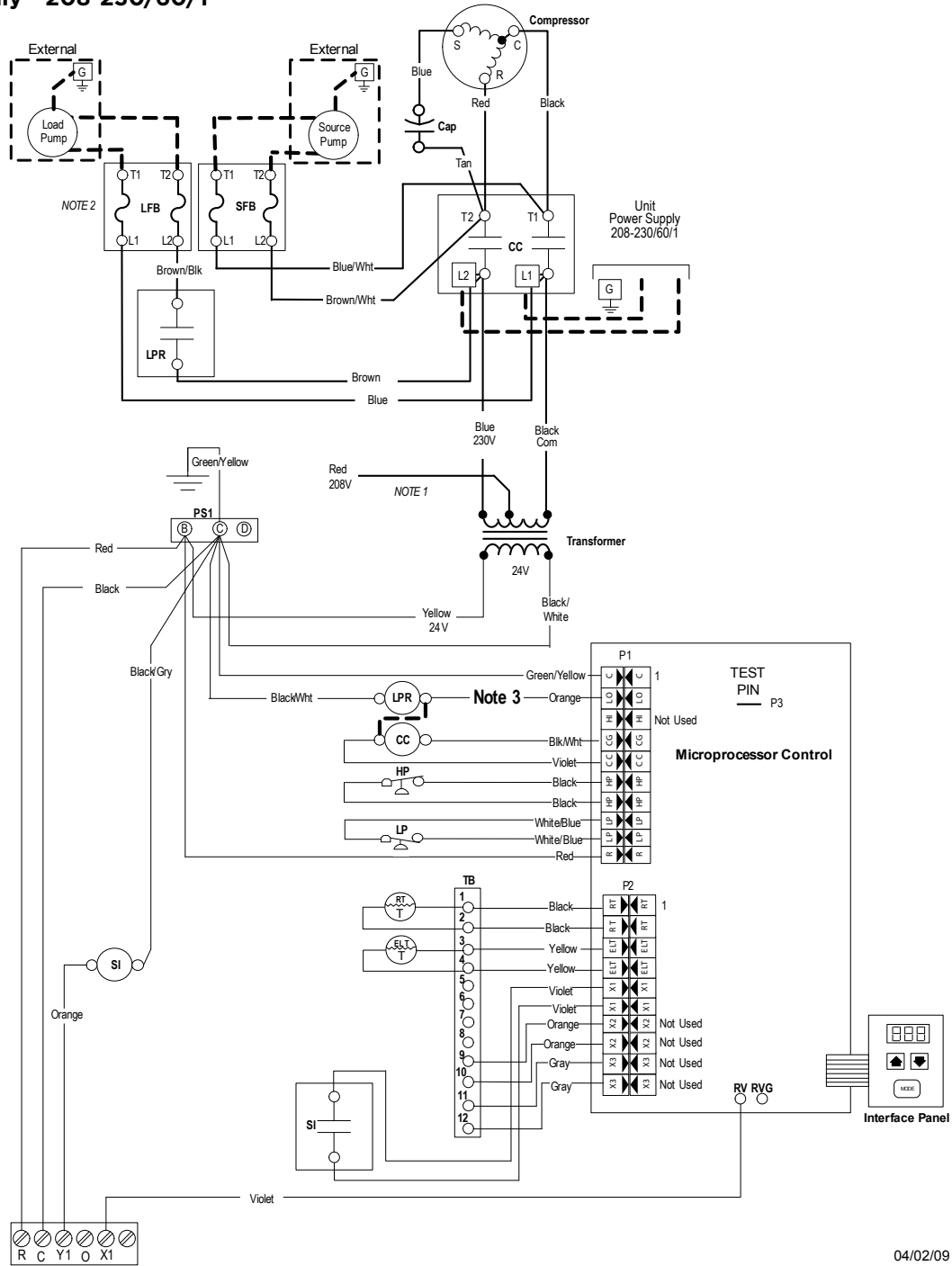

04/02/09

| Legend | | | |
|--|--|--|--|
| <p>— Factory low voltage wiring</p> <p>— Factory line voltage wiring</p> <p>- - - Field low voltage wiring</p> <p>- - - Field line voltage wiring</p> <p>· · · Optional block</p> <p>○ Quick connect terminal</p> <p>⊗ Screw terminal - field connection</p> <p>⊘ Fuse</p> | <p>CC - Compressor contactor</p> <p>RV - Reversing Valve output</p> <p>ELT - Entering Load Side Water Temperature</p> <p>HP - High pressure switch</p> <p>LP - Low pressure switch</p> <p>LPR - Load Pump Relay</p> <p>RT - Refrigerant Liquid line Temperature</p> <p>SI - Slave Input relay</p> <p>RC - Reversing Valve Coil</p> <p>LFB - Load Pump Fuse Block</p> <p>SFB - Source Pump Fuse Block</p> | <p>L1 Field wire lug</p> <p>⊕ Ground</p> <p>⊖ Relay Contacts - N.O., N.C.</p> <p>P Polarized connector</p> | <p>⊗ Switch - High pressure</p> <p>⊘ Switch - Low pressure</p> <p>⊙ Relay coil</p> <p>⊚ Capacitor</p> <p>⊛ Thermistor</p> |
| | | | <p>Notes:</p> <p>1. Taped and wire tied off</p> <p>2. 3AG10 Amp fuse</p> <p>3. For cycle load pump with a geo storage tank. Remove the orange wire from the LPR relay coil and install a jumper between the LPR relay coil and the comp contactor coil as shown in the schematic above.</p> |

Wiring Schematics - Residential cont.

NSW Reversible with IntelliStart - 208-230/60/1

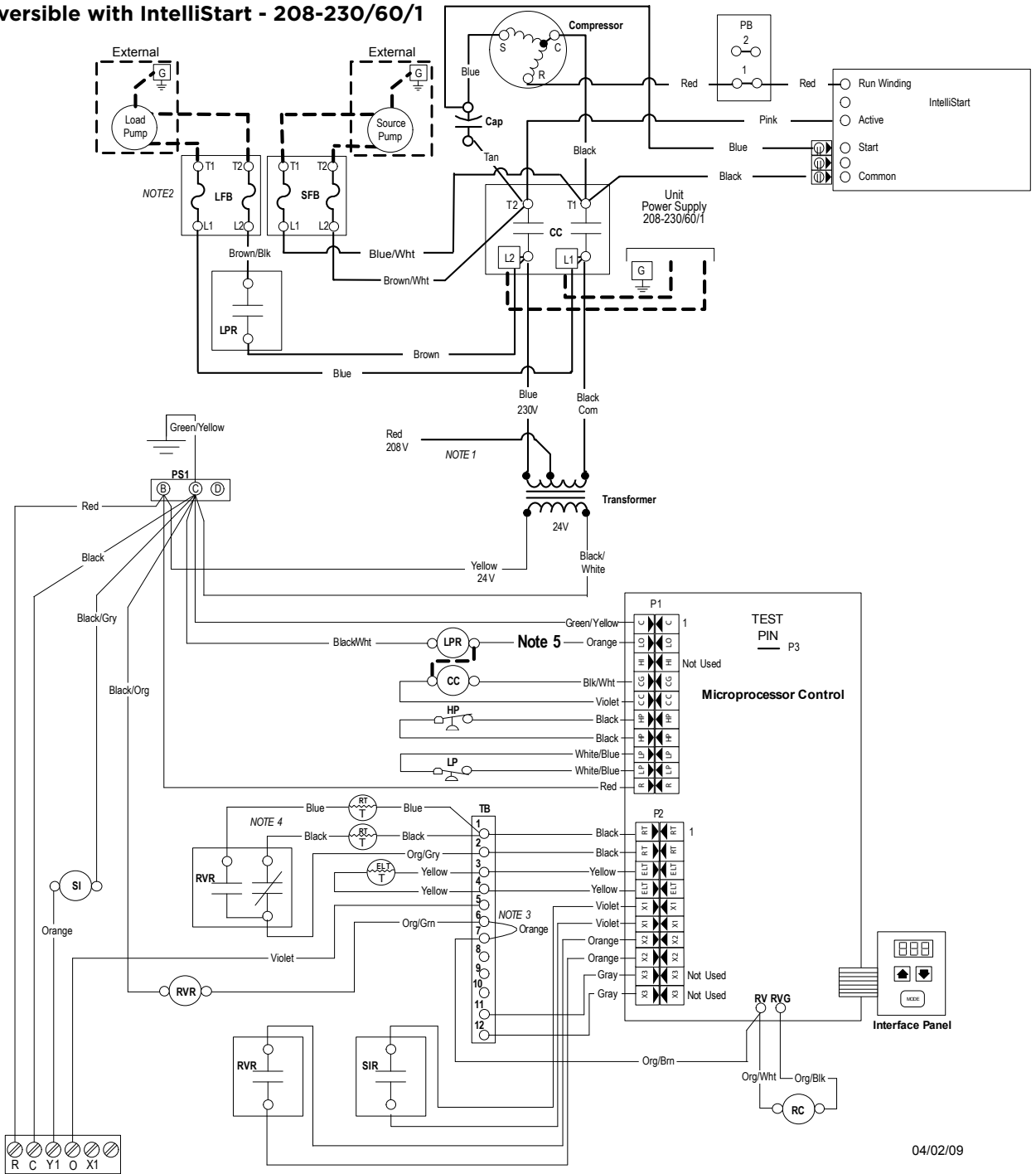

04/02/09

| Legend | | | |
|---|---|--|---|
| <p>— Factory low voltage wiring</p> <p>— Factory line voltage wiring</p> <p>- - - Field low voltage wiring</p> <p>- - - Field line voltage wiring</p> <p>- - - Optional block</p> <p>○ Quick connect terminal</p> <p>⊗ Screw terminal - field connection</p> <p>— Fuse</p> | <p>CC - Compressor Contactor</p> <p>RV - Reversing Valve Output</p> <p>ELT - Entering Load Side Water Temperature</p> <p>HP - High Pressure Switch</p> <p>LP - Low Pressure Switch</p> <p>LPR - Load Pump Relay Contacts</p> <p>RT - Refrigerant Liquid Line Temperature</p> <p>SIR - Slave Input Relay</p> <p>RC - Reversing Valve Coil</p> <p>LFB - Load Pump Fuse Block</p> <p>SFB - Source Pump Fuse Block</p> <p>RVR - Reversing Valve Relay</p> | <p>L1 Field wire lug</p> <p>⊕ Ground</p> <p>Relay Contacts - N.O., N.C.</p> <p>P Polarized connector</p> | <p>Switch - High pressure</p> <p>Switch - Low pressure</p> <p>Relay coil</p> <p>Capacitor</p> <p>Thermistor</p> |
| <p>Notes:</p> <ol style="list-style-type: none"> 1. Taped and wire tied off 2. 3AG 10Amp fuse 3. Move jumper wire to 5 and 6 for reversible secondary unit. 4. Black Thermistor - Source Coax Blue Thermistor - Load Coax 5. For cycle load pump with a geo storage tank. Remove the orange wire from the LPR relay coil and install a jumper between the LPR relay coil and the comp contactor coil as shown in the schematic above. | | | |

Wiring Schematics - Commercial

NSW Heating Only - 208-230/60/3

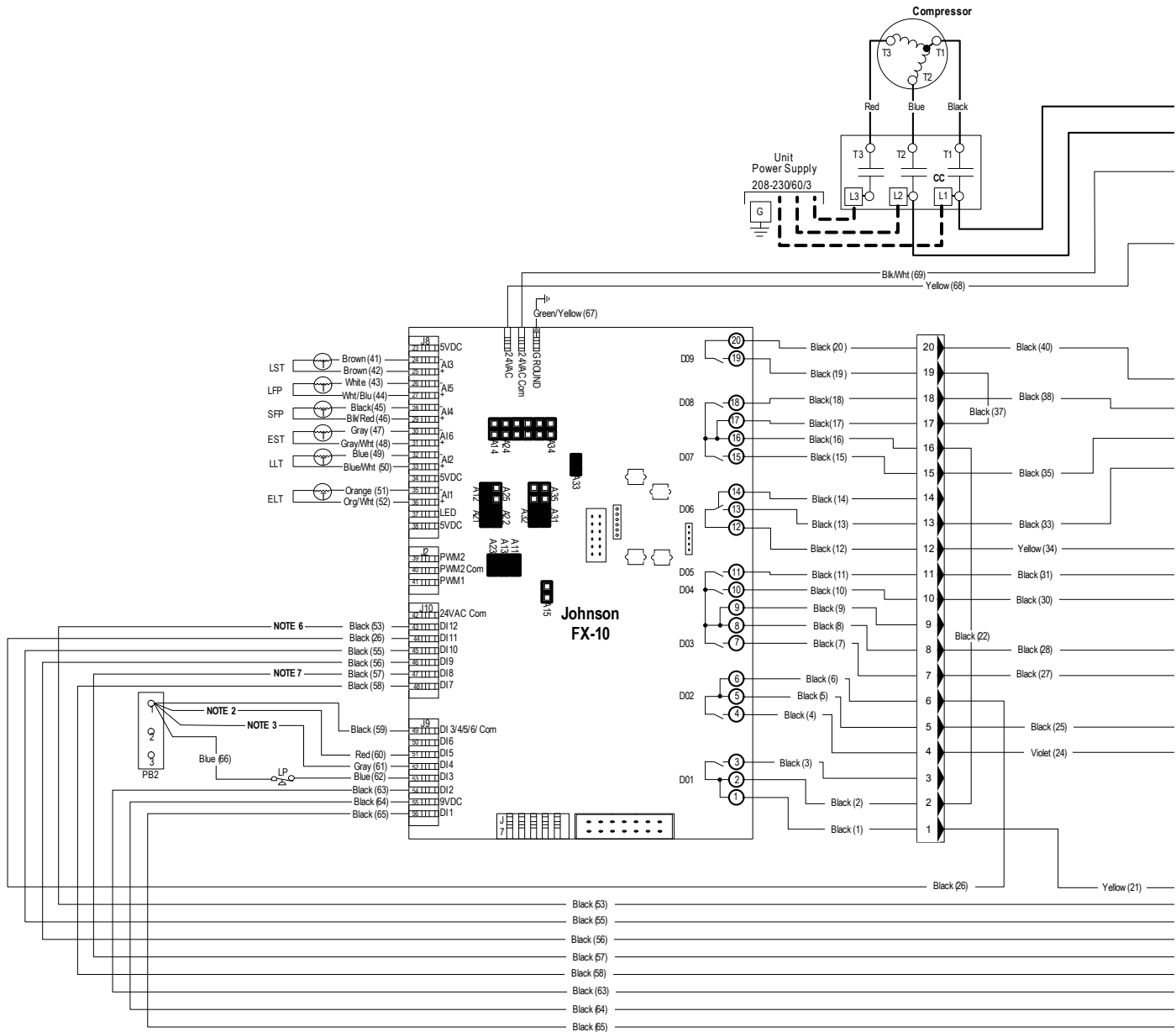

97P799-05

4/02/09

Legend

| | | | | |
|---|---|---|---|--|
| <p>— Factory low voltage wiring</p> <p>— Factory line voltage wiring</p> <p>— Field low voltage wiring</p> <p>— Field line voltage wiring</p> <p>--- Optional block</p> <p>--- Field Zone Sensor Wiring</p> | <p>● Internal junction</p> <p>⌈ L1 ⌋ Field wire lug</p> <p>⊥ Ground</p> <p>⊥⊥ Relay Contacts - N.O., N.C.</p> <p>⊕ Thermistor</p> <p>⊙ Relay coil</p> | <p>⊕ Switch - High pressure</p> <p>⊖ Switch - Low pressure</p> <p>⊔ Open Jumper</p> <p>⊓ Closed Jumper</p> <p>P Polarized connector</p> | <p>CC - Compressor contactor</p> <p>CP - Compressor Proving</p> <p>ELT - Entering Load Water Temp</p> <p>ES - Emergency Shutdown</p> <p>EST - Entering Source Water Temp</p> <p>HP - High pressure switch</p> <p>LFP - Load Freeze Protection</p> <p>LFS - Load Flow Proving Switch</p> <p>LLT - Leaving Load Water Temp</p> <p>LP - Low pressure switch</p> <p>LST - Leaving Source Water Temp</p> <p>RV - Reversing Valve coil</p> <p>SFP - Source Freeze Protection</p> <p>SFS - Source Flow Proving Switch</p> <p>TB - Terminal Board</p> | <p>Notes:</p> <p>1 - Switch Blue and Red wires for 208V operation</p> <p>2 - Disconnect for 15 degree load side freeze detection</p> <p>3 - Disconnect for 15 degree source side freeze detection</p> <p>4 - Acc 1 and ACC 2 outputs are cycled with the compressor.</p> <p>5 - R, C, Y1, and O inputs are for use with an aqua stat.</p> <p>6 - If no flow proving switch is being used on the load side, the LF terminal on the terminal board must be jumpered to the R terminal for the unit to operate.</p> <p>7 - If no flow proving switch is being used on the source side, the SF terminal on the terminal board must be jumpered to the R terminal for the unit to operate.</p> <p>8 - A closed contact will enable the emergency shutdown input (ES) and the compressor proving input (CP).</p> <p>9 - Primary over-ride input (POI) on a primary unit must be wired to R through a normally open contact. If the POI input is on a secondary unit connect the Primary Over-ride output (PO) from the primary unit to the POI terminal on the secondary unit.</p> <p>10 - Apply 24VAC to the O terminal for cooling.</p> |
|---|---|---|---|--|

Wiring Schematics - Commercial cont.

NSW Heating Only - 208-230/60/3

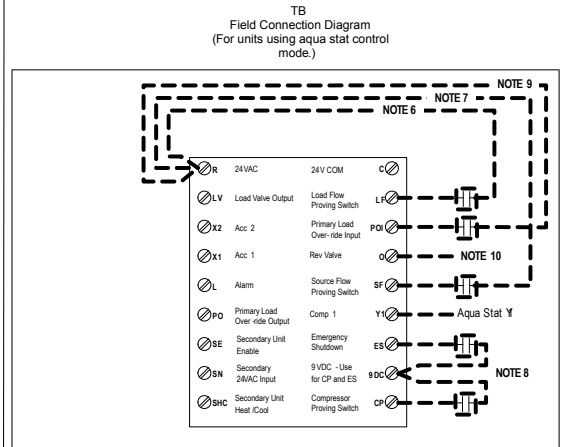
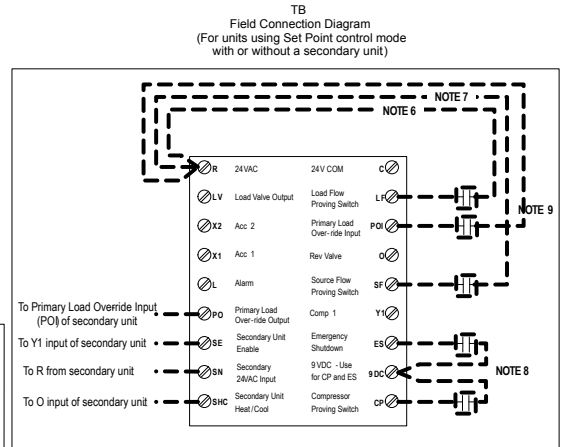
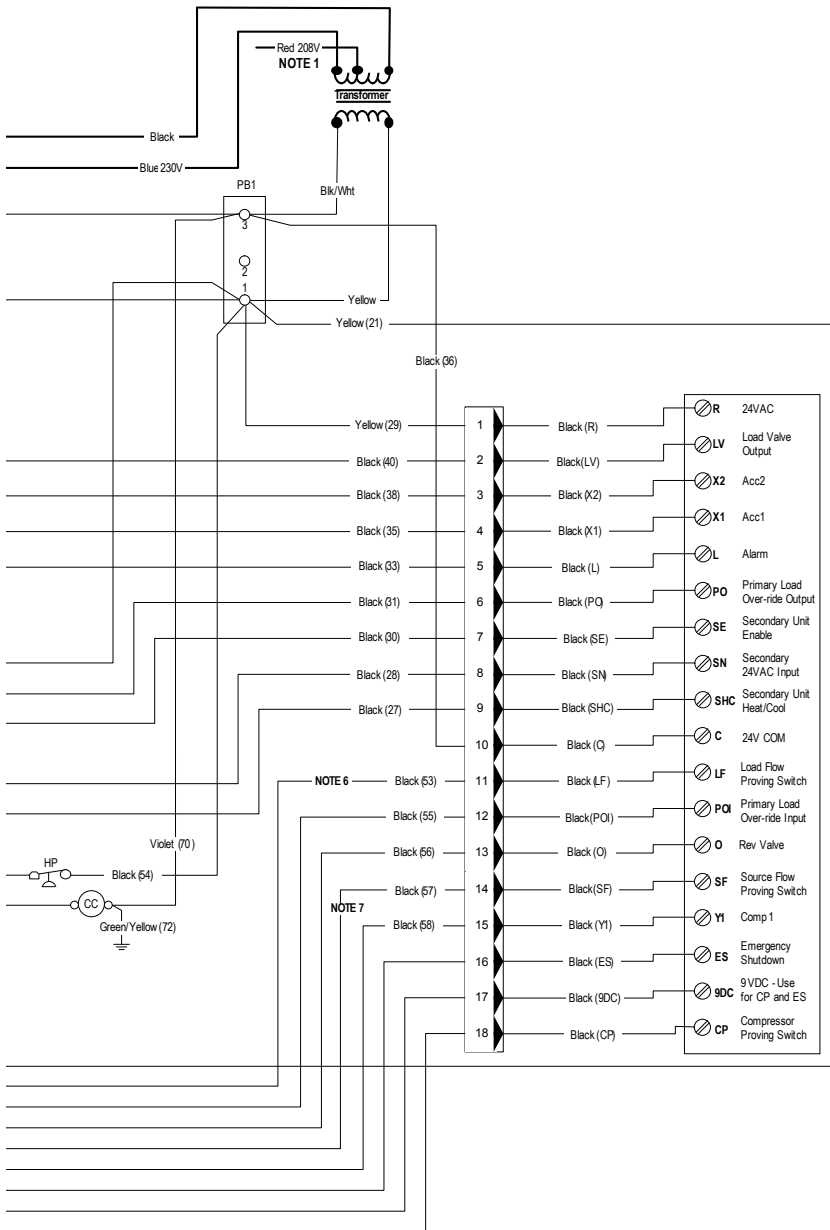

97P799-05

4/02/09

Wiring Schematics - Commercial cont.

NSW Reversible - 575/460/3

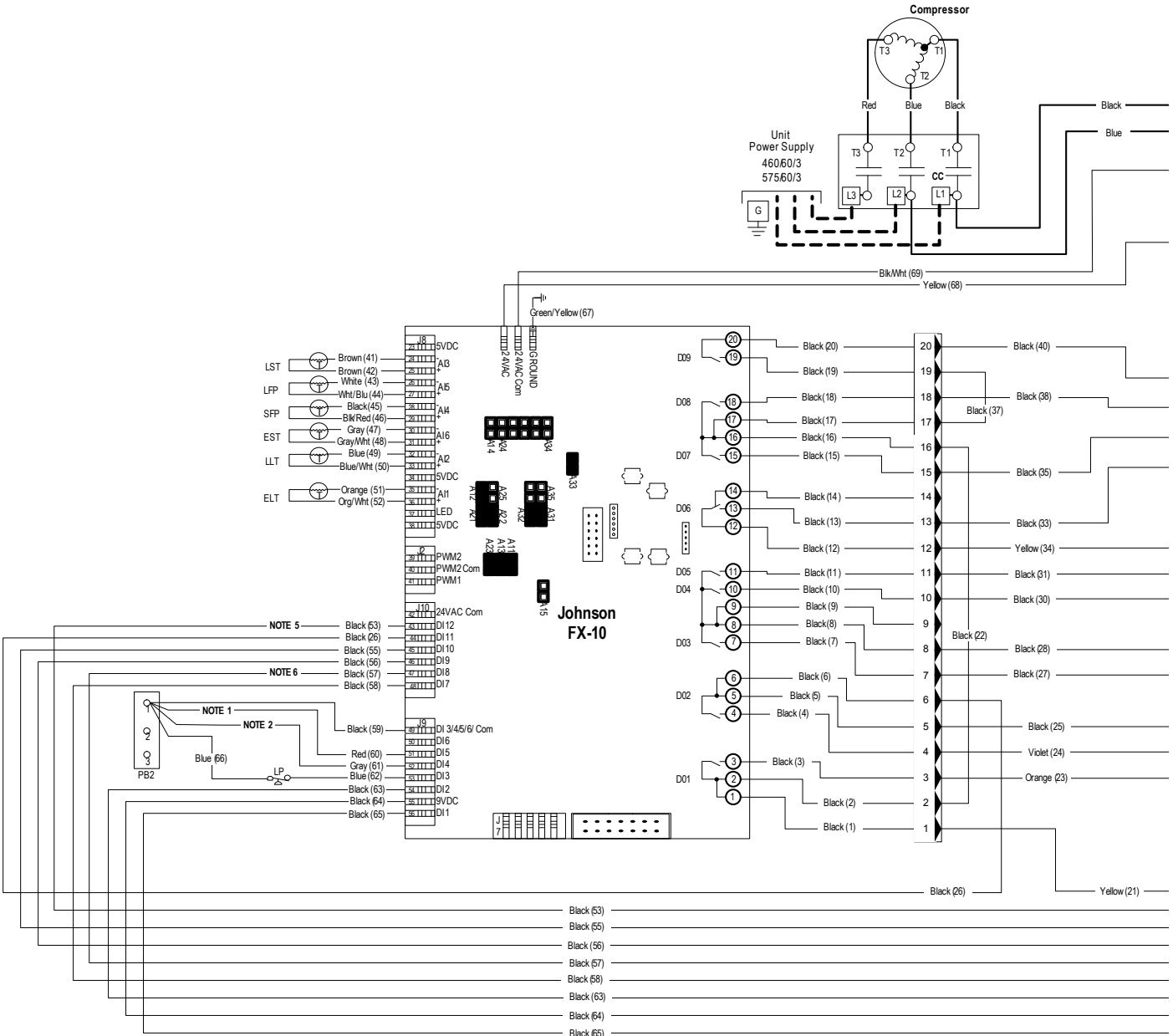

97P799-08

4/02/09

| Legend | | | |
|--------|-----------------------------|--|-------------------------------|
| | Factory low voltage wiring | | Internal junction |
| | Factory line voltage wiring | | Switch - High pressure |
| | Field low voltage wiring | | Switch - Low pressure |
| | Field line voltage wiring | | Open Jumper |
| | Optional block | | Closed Jumper |
| | Field Zone Sensor Wiring | | Relay Contacts- N.O., N.C. |
| | | | Relay coil |
| | | | Ground |
| | | | Thermistor |
| | | | Polarized connector |

CC - Compressor contactor
CP - Compressor Proving
ELT - Entering Load Water Temp
ES - Emergency Shutdown
EST - Entering Source Water Temp
HP - High pressure switch
LFP - Load Freeze Protection
LFS - Load Flow Proving Switch
LLT - Leaving Load Water Temp
LP - Low pressure switch
LST - Leaving Source Water Temp
RV - Reversing Valve coil
SFP - Source Freeze Protection
SFS - Source Flow Proving Switch
TB - Terminal Board

Notes:
 1 - Disconnect for 15 degree load side freeze detection
 2 - Disconnect for 15 degree source side freeze detection
 3 - Acc 1 and ACC 2 outputs are cycled with the compressor.
 4 - R, C, Y1, and O inputs are for use with an aqua stat.
 5 - If no flow proving switch is being used on the load side, the LF terminal on the terminal board must be jumpered to the R terminal for the unit to operate.
 6 - If no flow proving switch is being used on the source side, the SF terminal on the terminal board must be jumpered to the R terminal for the unit to operate.
 7 - A closed contact will enable the emergency shutdown input (ES) and the compressor proving input (CP).
 8 - Primary over-ride input (POI) on a primary unit must be wired to R through a normally open contact. If the POI input is on a secondary unit connect the Primary Over-ride output (PO) from the primary unit to the POI terminal on the secondary unit.
 9 - Apply 24VAC to the O terminal for cooling.

Wiring Schematics - Commercial cont.

NSW Reversible - 575/460/3

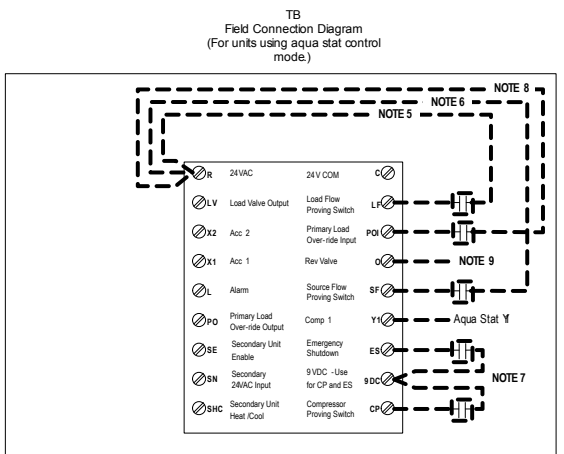
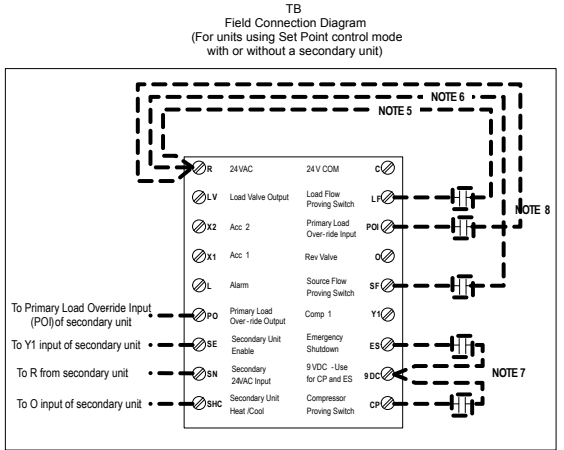
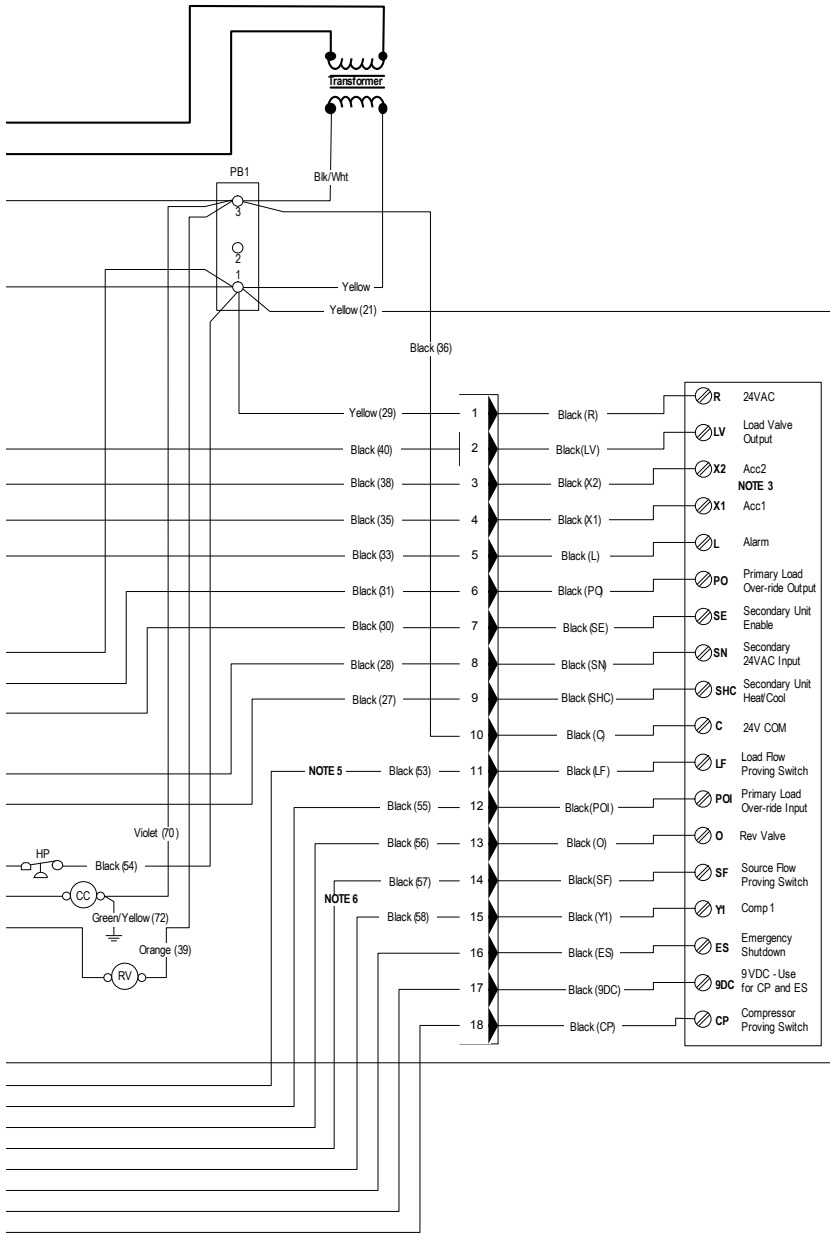

97P799-08

4/02/09

External Control

Primary Mode

In dedicated heating or cooling units, the unit is controlled by the internal controller. Compressor output is determined by the entering load-side water temperature.

The secondary output will be energized if two conditions occur:

1. The initial temperature is greater than **IC** away from the set point.
2. The change in temperature in a given period of time **P** is less than **d**.

In a reversible unit, the unit is controlled by the internal controller. Compressor output is determined by the entering load-side water temperature. For reversible units, the jumper wire must be positioned across **terminals 6 and 7**, (factory default set to this position). Reversible units do not have a secondary output.

NOTES: **SL** in the configuration menu must be set to **0**, (factory default). All parameters should be checked for each application on primary unit, (refer to the parameter table).



WARNING: Reversible units cannot be staged.

Aquastat Wiring for Dedicated Heating or Cooling Unit

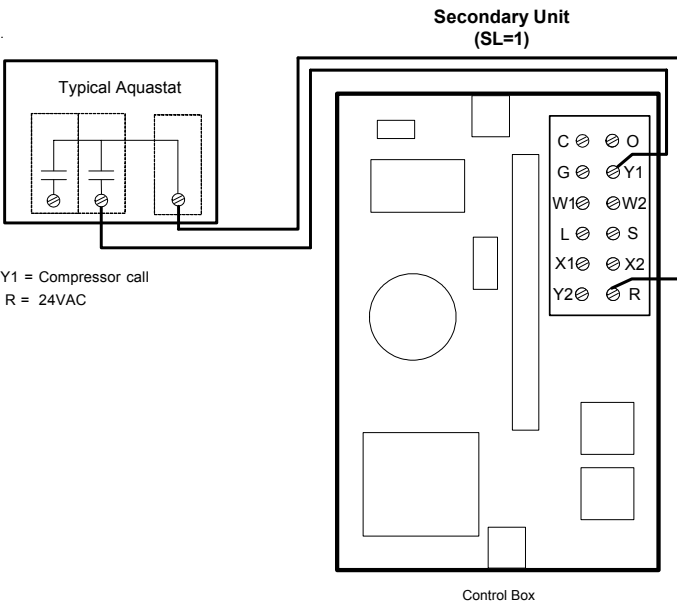

Secondary Mode

In dedicated heating or cooling units, secondary mode allows the unit to be controlled by an external source. Compressor output is determined by the Y1 input only.

The secondary output will be energized after the following condition occurs:

1. The change in temperature in a given period of time **P** is less than **d**.

In reversible units, secondary mode allows the unit to be controlled by an external source. Compressor output is determined by the Y1 input and the reversing valve is determined by the O input. In reversible units, the jumper wire must be positioned across terminals 5 and 6. Reversible units do not have a secondary input.

NOTES: **SL** in the configuration menu must be set to **1**. **P** and **d** must be setup for each secondary unit.

Wiring an Aquastat - Reversible Unit

- To create a secondary unit, set **SL** to 1 in the configuration menu.
- Position the jumper wire in the control box across terminals 5 and 6.

Aquastat Wiring for Reversible Unit

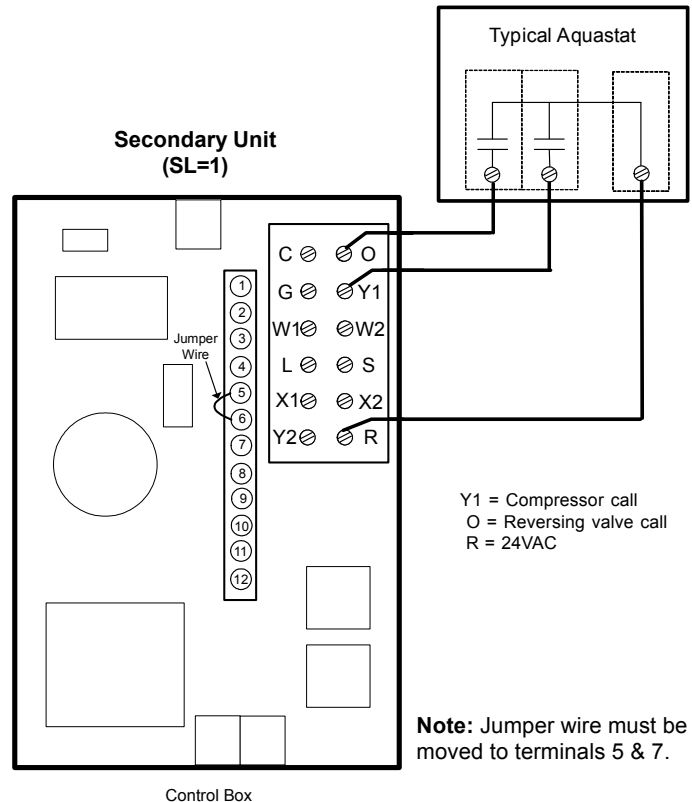

External Control cont.

Staging with Primary/Secondary Mode

Staging is only possible with dedicated heating or cooling units. Reversible units cannot be staged. Staging can be accomplished with primary/secondary modes or by using an aquastat.



WARNING: Do not stage more than 6 units.

The first stage must be setup as a primary unit. All other units must be setup as secondary units. The set point is stored in the primary unit. Once the set point in the primary unit has been satisfied, all units will immediately shutdown.

Wiring for Primary/Secondary Unit Staging

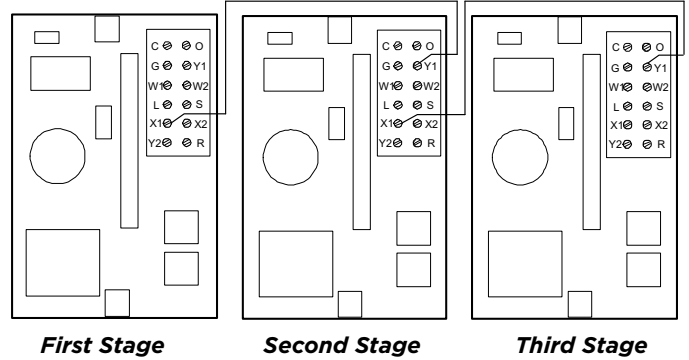

NOTES: X1 = Secondary output
Y1 = Compressor call

Staging with Aquastat

When staging units using an Aquastat, all units must be setup as secondary units.



WARNING: Do not stage more than 6 units.

Wiring for Dedicated Heating or Cooling Units with Aquastat

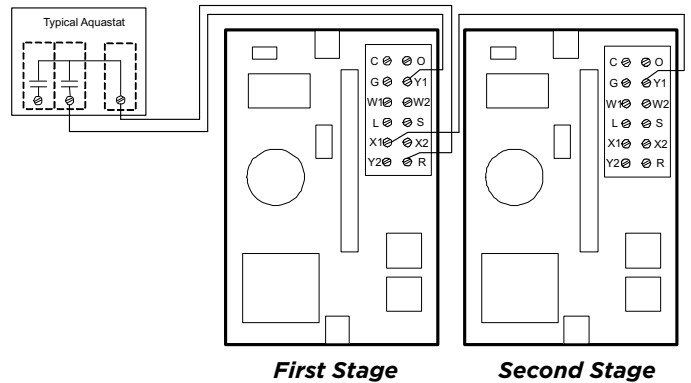

NOTES: X1 = Secondary output
Y1 = Compressor call
R = 24 VAC

Converting to a Dedicated Cooling Unit

Procedure to Convert a Heating Only Unit to a Cooling Only Unit

All non-reversible NSW units are built at the factory as dedicated heating units. Follow the procedures below to make the unit a dedicated cooling unit.

1. Shut off all power to the unit.
2. Remove the top and access panel.
3. Remove the brass in-well thermistor from the load water-in line.
4. Remove the brass plug from the source water-in line.
5. Place new Teflon® tape on the threads of the brass in-well thermistor.
6. Thread the brass in-well thermistor into the source water-in line.
7. Make sure the thermistor wires do not touch the discharge line.
8. Place new Teflon® tape on the threads of the brass plug.
9. Thread the brass plug into the load water-in line.
10. Refer to the labels on the unit for the location of ports and lines.
11. Connect the “Source Water-In” line to the port marked “Load Water-In.” Then, connect the “Source Water-Out” line to the port marked “Load Water-Out.”
12. Connect the “Load Water-In” line to the port marked “Source Water-In.” Then, connect the “Load Water-Out” line to the port marked “Source Water-Out.”

13. Open the control box.
14. Find the connection marked “P4” as shown in the Control Board with Jumper illustration.
15. Move the “P4” jumper from across 1 and 2 to across 2 and 3.
16. Close the control box and secure the screws.
17. Replace the top and access panel.
18. Make sure all screws have been re-installed.
19. Turn on the power.
20. Using the touch-pad, press the **UP** arrow.
21. The displays should blink “44” to show set point. Now, the unit should operate as a cooling only unit.

Jumper Pin Location

The location of the jumper pin determines the controller’s mode of operation. Move the jumper pins to the correct location for dedicated heating, dedicated cooling or reversible settings as indicated below.

| | |
|-------------------|-----------|
| Dedicated heating | - 1 & 2 * |
| Dedicated cooling | - 2 & 3 |
| Reversible | - 3 & 4 * |

* Indicates factory setting.

NOTE: A reversible unit **can not** be configured to heating only.

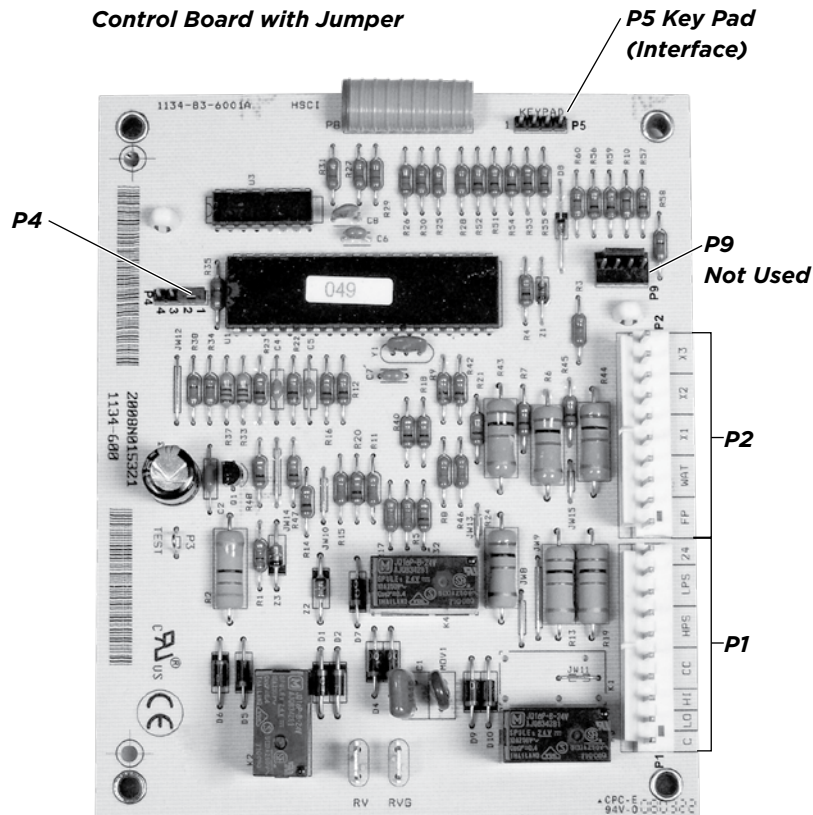

Unit Startup

Before Powering Unit

Check the following:

- High voltage wiring is correct and matches the nameplate.
- Fuses, breakers and wire size are correct.
- Piping is completed and water system has been cleaned and flushed.
- Air is purged from the closed loop system.
- Isolation valves are open and loop water control valves or loop pumps are wired.
- Service/access panels are in place.

Primary Unit Startup

1. Apply power to the unit. Upon power up, the unit will display the current operation mode.
 - **H** for dedicated heating.
 - **C** for dedicated cooling.
 - **U** for reversible units.
2. Press the mode button. The LED screen will display the current entering water temperature. The load pump will activate after a 5 minute delay.
3. Once the load pump has been active for 3 minutes, the controller will sample the temperature of the water system. In heating mode, when the temperature of the water shown on the display is lower than the set point the compressor will activate.
4. By using a pressure gauge and the P/T ports, check the pressure drop through both the load and source coaxes. Compare this to the capacity tables in the specification catalog to verify the proper flow rate through the unit.
5. Verify that the compressor, load side and source side pumps are operating.
6. After determining the flow rates, use a thermometer and the PT ports to determine the change in temperature on both the load and source side coaxes.
7. Compute the formula $GPM \text{ flow rate} \times \text{Change in temperature} \times 500$ (485 on source side if antifreeze/brine is used in the loop) = Heat of Extraction on the source side in heating, Heat of Rejection on the source side in cooling. To ensure proper operation, compare these values to the capacity tables in the specification catalog.
8. Press the down arrow on the keypad to reduce the set point below the incoming load temperature. Compressor should shut off and the load pump should shut off 30 seconds after the compressor.
9. Wait 7 minutes. The load pump should start to sample load temperature.
10. Compressor and source side circulator should not start.
11. Press the up arrow on the keypad to increase the set point to 5 degrees above the water temperature displayed on the LED screen.
12. Three minutes after the load pump activates, the compressor and source pump should activate.

Secondary Unit Startup

1. Apply power to the unit.
2. After a three to five-minute delay, the water temperature shall be sampled. If the controller receives a remote aquastat signal, the compressor shall activate.
3. Verify that the compressor and load side, source side pumps are running.
4. By using a pressure gauge and the PT ports, check the pressure drop through both the load and source coaxes, and compare this to the capacity tables in the specification catalog to verify the proper flow rate through the unit.
5. After determining the flow rates, use a thermometer and the PT ports to determine the change in temperature on both the load and source side coaxes.
6. Compute the formula $GPM \text{ flow rate} \times \text{Change in temperature} \times 500$ (485 on source side if antifreeze is used in the loop) = Heat of Extraction on the source side in heating, Heat of rejection on the source side in cooling. To ensure proper operation, compare these values to the capacity tables in the specification catalog.
7. Press the down arrow on the control to disrupt the remote aquastat signal. Unit should shut off.
8. Instruct the owner or operator about the correct control and system operation.

Standard Board - Control Features

Anti Short Cycle Time

The anti short cycle time consists of a three minute minimum “off” time plus a randomly chosen 0-2 minute additional “off” delay. The random delay is chosen by the control after each compressor shut down. The 3-5 minute startup delay is applied after all compressor shutdowns and also to system startups due to ac power interruption.

Safety Controls

The control board receives separate signals for a high pressure switch for safety, low pressure switch to prevent loss of charge damage, and a low suction temperature for freeze detection. Upon a 30-second measurement of the fault (immediate for high pressure), compressor operation is suspended and the fault will be shown on the display.

Setpoint Temperature Ranges

In Primary mode, the heating temperature setpoint range is adjustable from 60°F (15.5°C) to 130°F (54.4°C) with an adjustable deadband range of 1° - 15°F. The cooling setpoint temperature is adjustable from 0° (-17.7°C) to 85°F (29.4°C) with a fixed non-adjustable deadband of 5°F.

Load Pump Control

There are two options for controlling the load pump, Pump Sampling (PS) or Continuous Pump (C), and these are selectable in the service Menu.

Pump Sampling (PS)

In Primary Mode, the control operates on a 10 minute sample cycle in which the load pump is turned on and run to obtain a meaningful sample of the temperature the load is presenting. If the water temperature measured after the pump has been on for PS minutes (selected and adjusted from the Service Menu) is outside the user selectable deadband amount, dB (also selected and adjusted from the Service Menu), the compressor is turned on and Heating or Cooling is initiated. If the water temperature is within the deadband of the set point when sampled, the pump shuts off and is idle for (10 - PS) minutes when it starts another PS minute sample period. For example, if the PS setting is two minutes, the pump will run for 2 minutes before sampling the load temperature. If the water temperature is within the selected dead band temperature of the set point, the pump will shut off for 10 - 2 = 8 minutes before beginning another pump sampling cycle. Heating deadband is selectable in the Service Menu while the Cooling deadband is non-adjustable and fixed at 5°F.

Continuous Pump Mode (C)

If continuous pump mode (PS=C In Service Menu) is selected, the control will respond immediately to a recognized call or termination of call for heat or cool subject to minimum run times and anti short cycle delays.

Test Mode

Connection of a jumper wire from chassis ground to P3 will place the control in the test mode. This shortens most timing delays for faster troubleshooting. In the Primary Mode the control will respond immediately if a demand is present. The anti-short cycle delay is replaced by a 10 second pump and compressor on delay. Minimum compressor run time becomes 15 seconds. Test mode will remain in effect for a maximum of 15 minutes at any one time should the jumper remain in place.

Fault Conditions

There are two classes of faults, retry faults and no retry faults. Retry faults allow the system to try 2 additional times to establish operation before displaying the fault condition and entering lockout. No-Retry Faults prevent compressor operation for the duration of the fault. If the fault activity ceases while the system is inactive, the fault code is cleared from the display and operation is permitted.

Retry Faults

High pressure, low pressure and freeze detection faults are retried twice before locking the unit out and displaying the fault condition.

High Pressure (HP)

Compressor operation will be disabled immediately when the normally closed high-pressure switch is opened momentarily (set at 600 psi). The LED display shall read “HP” only when the control has completed two retries, and is in lockout. The pump continues to operate throughout the retry period.

Low Pressure (LP)

Compressor operation will be disabled when the normally closed low-pressure switch (set at 40 psi) has opened for 30 continuous seconds (if the bypass period has been satisfied). The Low Pressure switch is bypassed (ignored) for two minutes after startup. The LED display shall read “LP” only when the control has completed two retries, and is in lockout. The pump continues to operate throughout the retry period.

Freeze Detection (FP)

Compressor and loop pumps will be disabled if the control senses that the refrigerant loop temperature drops below the FP value (set in the service menu) for 30 continuous seconds (if the bypass period has been satisfied). If the compressor and the loop pump outputs are disabled because of this condition, the LED display shall read “FP.” There is a two (2) minute by-pass timer for the freeze detection at compressor start up.

No-Retry Faults

High Temperature, Water Temperature Probe Open, Water Temperature Probe Closed and Brown Out faults prevent compressor operation for the duration of the

Standard Board - Control Features cont.

fault. If the fault activity ceases while the system is inactive, the fault code is cleared from the display and operation is permitted.

High Temperature

Compressor operation will be disabled when the control senses an entering load side water temperature of 130° F regardless of mode.

Water Temperature Probe Open (PO)

Compressor and pump operation will be disabled when the control senses that the water probe is open or has infinite resistance. The LED display shall read "PO."

Water Temperature Probe Closed (HC)

Compressor and pump operation will be disabled when the control senses that the water probe is closed or has no resistance. The LED display shall read "HC."

Freeze Detection Probe Open (dO)

Compressor and pump operation will be disabled when the control senses that the freeze detection probe is open or has infinite resistance. The LED display shall read "dO."

Freeze Detection Probe Closed (dC)

Compressor and pump operation will be disabled when the control senses that the freeze detection probe is closed or has no resistance. The LED display shall read "dC."

Brown-Out (BO)

All operation will be disabled when the control voltage falls below 18VAC for 10-15 continuous seconds.

Resetting Lockouts

To reset any lockout condition, place the unit into the standby mode for at least 5 seconds. After the lockout has been reset, the fault display will be turned off. Cycling control power will also clear the display. Non-Retry Faults must be cleared for the display and lockout to clear.

Power Down (power outage)

The controller will store its Service Menu settings and current Mode selection in non-volatile memory so that these settings are retained through any power outage. Current operating conditions are not stored and the controller must evaluate its current conditions.

Standard Control - Panel Configuration

The control panel allows you to access the service menu on the unit. The control panel has three 7-segment LED screens that display the:

- Water temperature
- Configuration menu

There are six (6) LED indicators that indicate when the SECONDARY OUTPUT is active or the unit is on one of the following modes:

- Standby Mode
- Heating Mode
- Cooling Mode
- Primary (Master) Mode

The control panel has both UP and DOWN (arrow) buttons and a MODE button. The UP and DOWN buttons allow you to change the set point or scroll through the configuration menu. The MODE button allow you to change mode as well as enter and exit parameters while in configuration mode.

Control Panel Configuration

The configuration menu allows you to properly set and adjust all of the unit's operating parameters to fit your application.

To enter configuration mode and configure parameters, follow these procedures:

1. Hold down both the UP and DOWN buttons simultaneously for five seconds, or until the LED screen displays "**LC**".
2. Press the UP or DOWN arrow until "**50**" is displayed.
3. Press the MODE button. The screen should display "**SC**" to indicate the controller is in configuration mode.
4. Once in configuration mode, press the UP or DOWN arrow to scroll through the menu.
5. Press the MODE button to enter the parameter. (Refer to the parameter table below for a list of configurable parameters.)
6. Once in the parameter, press the UP or DOWN arrow to change the parameter.
7. Press the MODE button to return to the main menu.

NOTE: The controller will exit the configuration mode after 30 seconds if no key is pressed.

Control Panel

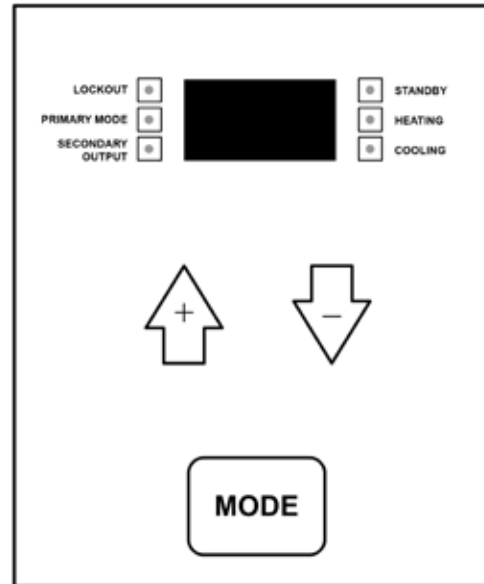

Changing the Setpoint

1. Pressing the UP or DOWN arrow once will display the setpoint.
2. The setpoint will flash.
3. When the setpoint is flashing, the **UP** and **DOWN** arrow will change the setpoint by one degree.
4. In Primary mode, the heating temperature setpoint range is adjustable from 60°F (15.5°C) to 130°F (54.4°C) with an adjustable deadband range of 1° - 15°F. The cooling setpoint temperature is adjustable from 0° (-17.7°C) to 85°F (29.4°C) with a fixed non-adjustable deadband of 5°F.

Standard Control - Panel Configuration cont.

Remote Aquastat Secondary Mode (Y1)

In secondary mode the compressor output is determined by an external aquastat. The compressor shall engage 10 seconds after the Y1 call has been received. The compressor shall de-activate 10 seconds after the Y1 has been removed. The secondary output is controlled by a Derivative Controller. If the change in the water temperature is less than a selected value (d) in a selected period of time (P), the secondary output shall activate.

Parameter Functions and Settings





| Parameter | Function | Description | Factory Setting | Range | Increments |
|-----------|-------------------------------|---|-----------------|--------------------|------------------------------|
| SC | Calibrate the Water Sensor | This will allow the temperature displayed to be adjusted to match a temperature reading from an external source. | 0° | -9° to 10° | 1 |
| dB | Dead Band (Heating) | This parameter is used to determine when the compressor should be activated. If the temperature is below the setpoint minus the dB value (in heating mode) then the compressor will activate. The cooling deadband is fixed at 5°F and non-adjustable. | 1°F | 1° to 15° | 1 |
| CF | Celsius/ Fahrenheit Selection | This parameter selects the units for which the temperature will be displayed. | F | F or C | N/A |
| FP | Freeze Detection | There are three settings for this parameter; OL, CL, and P. OL is the open loop setting which corresponds to 32°F (0°C). CL is the closed loop setting which is 15°F (-10°C). P is the process setting which is 5°F (-15°C). | 32°F | P,CL,OL | N/A |
| SL | Primary/ Secondary Setting | Primary mode utilizes an internal aquastat to determine the activity of the compressor. In secondary mode the compressor output is determined by an external aquastat. | 0 (Primary) | 0 or 1 | 1 = Secondary 0 = Primary |
| IC | Initial Condition | This parameter is used to determine the state of the secondary output of the primary unit. If the actual water temperature is greater than the IC value away from the set point, the secondary output will be activated. | 10° | 0° to 20° | 1° |
| d | Derivative | This parameter is used to determine the state of the secondary output of the primary and secondary unit. If the change in temperature is less than the d value the secondary output will activate. | 1°F | 0° to 5° | 1° |
| P | Period | This determines how often the derivative will be calculated. | 5 min | 1 to 5 min | 1 min |
| PS | Pump Sampling Time Selection | This parameter determines how long the pump is activated before the controller takes a sample of the water temperature. The range of this parameter is from 1 to 5 minutes and is factory set to 3 minutes. The pump can also be set to run continuously when PS is set to C. | 3 min | 1 to 5 min or C | 1 min |
| Fd | Freeze Detection Display | This displays the current temperature of the freeze detection sensor. | N/A | 0° to 130° | N/A |

Optional Controls

FX10 Control

The FX10 control provides unparalleled capability in several areas including performance monitoring, energy management, and service diagnosis, and then communicates it all thru standard DDC protocols like N2, Lon and BACnet (MS/TP @ 19,200 Baud Rate).

The most unique feature is integrating the FX10 into the Envision Series as both the heat pump and DDC controller providing both a cost advantage and providing features not typically found on WLHP controls. This integration allows heat pump monitoring sensors, status and service diagnosis faults to be communicated thru the DDC direct to the building automation system (BAS), giving building supervisors detailed and accurate information on every piece of equipment without removing an access panel!

| Control | General Description | Application | Display/Interface | Protocol |
|---|---|--|--|-----------------------------------|
| FX10  | The FX10 microprocessor control is self contained control featuring LP, LOC, HP, LWT, and condensate overflow fault modes can be displayed on BAS system. Optional handheld Medium User Interface (MUI) Control can be used for additional setup or servicing. Program customization is possible. | Cannot be integrated with centralized building automation systems. Software can be customized for specific projects. | Optional Medium User Interface (MUI) can be used as a field service tool. | Standalone |
| FX10 w/N2  | FX10 Control functions as both unitary heat pump control and DDC communication, therefore detail operational and fault information is available to BAS. Other features are same as FX10 with addition of Johnson Controls N2 compatibility. | Same as FX10 with Johnson Controls N2 BAS compatibility. | Optional Medium User Interface (MUI) can be used as a field service tool. | Johnson Controls N2 network |
| FX10 w/LonWorks  | FX10 Control functions as both unitary heat pump control and DDC communication, therefore detail operational and fault information is available to BAS. Other features are same as FX10 with addition of LonWorks compatibility. | Same as FX10 with LonWorks BAS compatibility. | Optional Medium User Interface (MUI) can be used as a field service tool. | LonWorks |
| FX10 w/BACnet  | FX10 Control functions as both unitary heat pump control and DDC communication, therefore detail operational and fault information is available to BAS. Other features are same as FX10 with addition of BACnet compatibility. | Same as FX10 with BACnet BAS compatibility. Due to communication speed, no more than 40 units should be connected to a single trunk of the network. | Optional Medium User Interface (MUI) can be mounted or used as field service tool. | BACnet - MS/TP (19,200 Baud Rate) |

Optional Controls - FX10 cont.

FX10 Advanced Control Overview

- The Johnson Controls FX10 board is specifically designed for commercial heat pumps and provides control of the entire unit as well as input ports for Open N2, LonTalk, BACnet (MS/TP @ 19,200 Baud Rate) communication protocols as well as an input port for a user interface. The user interface can be used to aid in diagnostics and unit setup and is optional on all NSW units. A 16-pin low voltage terminal board provides terminals for common field connections. The FX10 Control provides:
 - Operational sequencing
 - High and low-pressure switch monitoring
 - General lockout
 - Freeze Detection Temperature Sensing
 - Lockout mode control
 - Emergency shutdown mode
 - Random start and short cycle protection

Short Cycle Protection

Allows a minimum compressor “off” time of five minutes and a minimum “on” time of two minutes.

Random Start

A delay of 1 to 120 seconds is generated after each power-up to prevent simultaneous startup of all units within a building after the release from an unoccupied cycle or power loss.

Emergency Shutdown

A field-applied dry contact can be used to place the control into emergency shutdown mode. During this mode, all outputs on the board are disabled.

Freeze Detection Temperature Limit

Field selectable for 15°F or 30°F (-9° or -0.56°C)

Installation Options

- Standalone controlled by standard aqua stat
- Integrated into BAS by adding communication module

Accessory Outputs

Quantity 2. Cycled with the compressor. Field selectable for normally open (factory default) or normally closed through the building automation system or user interface.

User Interface

4 x 20 backlit LCD

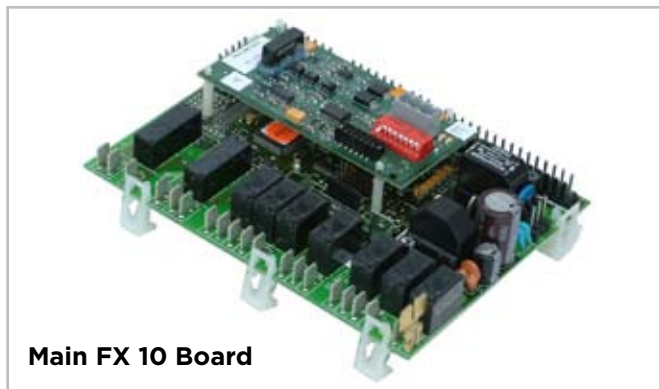

Main FX 10 Board

Optional Plug-in Communication Modules - (compatible with standard BAS protocols)

- Open N2
- LonTalk
- BACnet (MS/TP @ 19,200 Baud Rate, 30 unit max per trunk line)

Display

One local display is optional on all NSW units. Up to 2 displays, either 1 local and 1 remote, or 2 remote. (A 2-display configuration requires identical displays.) Local display can be up to 3 meters from the controller, power supply, and data communication. Remote display can be up to 300 meters from the controller. Remote display must be independently powered with data communication done via 3 pole shielded cable.

Control Timing & Fault Recognition Delays

| | |
|---|---------------|
| Lead compressor “ON” delay | 90 seconds |
| (not applicable for single compressor models) | |
| Minimum compressor “ON” time | 2 minutes |
| (except for fault condition) | |
| Short cycle delay | 5 minutes |
| Random start delay | 0-120 seconds |
| High pressure fault | <1 second |
| Low pressure fault | 30 seconds |
| Freeze detection fault | 0-30 seconds |
| Low pressure/freeze fault bypass | 2 minutes |

NOTES: Refer to Submittal Data SD1981, Application Guide AGFX10, or BACnet Protocol Implementation Conformance Statement for more information.

Optional Controls - FX10 cont.

FX10 Microprocessor and BAS System



The FX10 is a microprocessor based control that not only monitors and controls the heat pump but also can communicate any of this information back to the building automation system (BAS). This means that not only does the control monitor the heat pump at the unit you can also monitor and control many of the features over the BAS. This clearly puts the FX10 in a class of its own.

The control will enumerate all fault conditions (HP, LP, LOC, and Freeze Detection) over a BAS as well as display them on a medium user interface (MUI). HP, LP, and Freeze Detection faults can all be reset over a BAS. A Loss Of Charge fault can not be reset or bypassed until the problem has been corrected. A MUI is invaluable as a service tool for the building service team.

The unit can be commanded to run by applying Y1, Y2, and O commands to the terminal board or commanded through a BAS. The control board is wired with quick connect harnesses for easy field change out of a faulty control board. An alarm history can be viewed through the MUI and will be held in memory until the unit is power cycled.

The FX10 control has unused analog and digital inputs for field installed items such as water temperature or current status switches. The control has unused binary and PWM outputs that can be commanded over the BAS for field use. A Medium User Interface (MUI) for control setup and advanced diagnostics is standard on all NSW units.

Standard Features

- Anti Short Cycle
- High Pressure Protection
- Low Pressure Protection
- Freeze Detection
- Loss of Charge Detection
- Random Start
- Display for diagnostics
- Reset Lockout at disconnect or through BAS
- 2 Accessory outputs
- Optional BAS add-on controls

DDC Operation and Connection

Other optional network protocol boards that can be added to the FX10 are:

- Johnson Control N2
- LonWorks
- BACnet
 - MS/TP @ 19,200 Baud rate
 - Limit devices to 40 on a single trunk line.

Control and Safety Feature Details Emergency Shutdown

The emergency shutdown mode can be activated by a command from a facility management system or a closed contact on BI-2. The default state for the emergency shutdown data point is off. When the emergency shutdown mode is activated, all outputs will be turned off immediately and will remain off until the emergency shutdown mode is de-activated. The first time the compressor starts after the emergency shutdown mode has been de-activated, there will be a random start delay present.

Lockout Mode

Lockout mode can be activated by any of the following fault signals: refrigerant system high pressure, refrigerant system low pressure, or freeze detection. When any valid fault signal remains continuously active for the length of its recognition delay, the controller will go into fault retry mode, which will turn off the compressor. After the compressor short cycle delay, the compressor will attempt to operate once again. If three consecutive faults occur in 60 minutes, the unit will go into lockout mode, turning off the compressor, enabling the alarm output until the controller is reset. If the control faults due to the low pressure input being open during the pre-compressor startup check, the control will go into lockout mode immediately, disabling the compressor from starting and enabling the alarm output. The lockout condition can be reset by powering down the controller, by a command from the BAS, or by holding the ESC and Return keys on the user interface for 5 seconds.



Optional Controls - FX10 cont.

NSW Freeze Detection

The freeze detection sensor will monitor the liquid refrigerant temperature entering the water coil in the heating mode. If the temperature drops below the freeze detection trip point for the recognition delay period, the condition will be recognized as a fault. The freeze detection trip point will be factory set for 30°F and will be field selectable for 15°F by removing a jumper wire on BI-4 for the source and BI-5 for the load. The freeze detection fault condition will be bypassed for 2 minutes at normal compressor startup to allow the refrigeration circuit to stabilize. If the freeze detection sensor becomes unreliable at any time compressor operation will immediately be suspended until the problem is corrected. This will be displayed as an alarm on the BAS and the MUI. This alarm will be reported as “Water Low Temp Limit”.

High Pressure

The high-pressure switch shall be a normally closed (NC) switch that monitors the systems refrigerant pressure. If the input senses the high-pressure switch is open it must disable the compressor output immediately and count the fault. The compressor minimum on time does not apply if the high-pressure switch opens. The compressor will not restart until the compressor short cycle time delay has been satisfied.

Low Pressure

The low-pressure switch shall be a normally closed (NC) switch that monitors the systems refrigerant pressure. The input shall be checked 5 seconds before compressor start up and then ignored for the first 2 minutes after the compressor output (BO-2) is enabled. If the switch is open continuously for 30 seconds during compressor operation the compressor output (BO-2) will be disabled. The compressor will not restart until the compressor short cycle time delay has been satisfied.

Alarm Outputs

The alarm output will be enabled when the control is in the lockout mode and will be disabled when the lockout is reset.

Test Mode

By holding the ESC and down arrow keys on the MUI for 5 seconds will put the control into test mode. In test mode the random start delay and the compressor fixed on delay time will both be shortened to 5 seconds and the reversing valve will be allowed to cycle without shutting down the compressor. If an MUI is connected to the control LED 8 will flash and the words “Test Mode Enabled” will be shown on the LCD display when the control is in test mode. Test mode will be disabled after a power cycle, 30 minute timeout, or by holding the ESC and Up arrow keys on the MUI.

Sequence of Operation

Power Fail Restart

When the controller is first powered up, the outputs will be disabled for a random start delay. The delay is provided to prevent simultaneous starting of multiple heat pumps. Once the timer expires, the controller will operate normally.

Random Start Delay

This delay will be used after every power failure, as well as the first time the compressor is started after the control exits the unoccupied mode or the emergency shutdown mode. The delay should not be less than 1 second and not longer than 120 seconds. If the control is in test mode the random start delay will be shortened to 5 seconds.

Compressor Minimum On Delay

The compressor minimum on delay will ensure that the compressor output is enabled for a minimum of two (2) minutes each time the compressor output is enabled. This will apply in every instance except in the event the high pressure switch is tripped or emergency shutdown then the compressor output will be disabled immediately.

Compressor Minimum Off Delay Time

The compressor minimum time delay will ensure that the compressor output will not be enabled for a minimum of five (5) minutes after it is disabled. This allows for the system refrigerant pressures to equalize after the compressor is disabled.

Heating Cycle

The control will run the unit in heating mode when there is no command on the O/B terminal on the terminal board.

Cooling Cycle

The control will run the unit in cooling mode when there is a command on the O/B terminal on the terminal board.

MUI Alarm History Reporting

If a fault occurs the fault will be recorded in history for display on the medium user interface in the History Menu. Each fault type will be displayed in the history menu with a number between 0 and 3. A reading of 3+ will mean that fault has occurred more than three times in the past. The history menu can be cleared with a power cycle only. Alarm date and time are not included in the history.

Optional Controls - FX10 cont.

Inputs and Outputs Configuration

Field Selectable Options

Load and Source Freeze Detection Setpoint

The freeze detection setpoint input allows you to adjust the freeze detection setpoint for either the load or source sides of the heat pump. When the jumper is installed on BI-5 the load freeze detection setpoint is factory set for 30°F. When the jumper on BI-5 is removed the load freeze detection setpoint will be 15°F. When the jumper is installed on BI-4 the source freeze detection setpoint is factory set for 30°F. When the jumper on BI-4 is removed the source freeze detection setpoint will be 15°F. **NOTE: Piping circuit must be antifreeze protected to the set levels or the warranty will be voided.**

Accessory Output

The Accessory Outputs will be energized 90 seconds prior to the compressor output being energized. When the compressor output is turned off the accessory outputs will be deactivated immediately. The outputs are selectable for normally open or normally closed operation through the Medium User Interface or through the Building Automation System.

Control Accessories

- A99 Sensor
- MUI (LCD User interface) for diagnostics and commissioning
- MUIK3 - Panel Mount, Portable
- MUIK4 - Wall Mount

AHRI/ISO 13256-2 Performance Ratings

English (IP) Units

| Model | Capacity Modulation | Flow Rate | | Water Loop Heat Pump | | | | Ground Water Heat Pump | | | |
|-------|---------------------|-----------|------------|----------------------|-------------|-------------|------------|------------------------|-------------|-------------|------------|
| | | | | Cooling | | Heating | | Cooling | | Heating | |
| | | Load Gpm | Source Gpm | 86°F Source | 53.6°F Load | 68°F Source | 104°F Load | 59°F Source | 53.6°F Load | 50°F Source | 104°F Load |
| 018 | Single | 5 | 5 | 16,400 | 14.0 | 22,200 | 4.5 | 18,800 | 22.9 | 18,500 | 3.7 |
| 025 | Single | 7 | 7 | 23,700 | 13.6 | 32,800 | 4.6 | 26,700 | 21.2 | 27,100 | 3.8 |
| 040 | Single | 10 | 10 | 35,900 | 15.5 | 47,900 | 4.8 | 40,900 | 23.4 | 39,100 | 3.9 |
| 050 | Single | 15 | 15 | 49,800 | 13.9 | 65,000 | 4.4 | 55,600 | 21.6 | 54,200 | 3.7 |
| 060 | Single | 18 | 18 | 55,400 | 13.6 | 78,000 | 4.7 | 62,500 | 20.6 | 63,200 | 3.8 |
| 075 | Single | 19 | 19 | 66,000 | 12.3 | 93,100 | 4.2 | 74,100 | 18.0 | 77,100 | 3.5 |

| Model | Capacity Modulation | Flow Rate | | Ground Loop Heat Pump | | | |
|-------|---------------------|-----------|------------|-----------------------|-------------|-------------|------------|
| | | | | Cooling | | Heating | |
| | | Load Gpm | Source Gpm | 77°F Source | 53.6°F Load | 32°F Source | 104°F Load |
| 018 | Single | 5 | 5 | 17,300 | 16.6 | 14,700 | 2.9 |
| 025 | Single | 7 | 7 | 24,700 | 15.8 | 22,000 | 3.0 |
| 040 | Single | 10 | 10 | 37,700 | 17.5 | 30,500 | 3.1 |
| 050 | Single | 15 | 15 | 51,500 | 16.4 | 44,200 | 3.1 |
| 060 | Single | 18 | 18 | 58,000 | 15.7 | 50,100 | 3.0 |
| 075 | Single | 19 | 19 | 68,400 | 14.0 | 61,500 | 2.9 |

NOTES: All ratings based upon 208V operation. 7/13/09
 Rated in accordance with, but not certified by, AHRI.
 AHRI does not currently certify water-to-water products under AHRI/ISO 13256-2.
 EnergyStar does not currently recognize water-to-water products.

Pressure Drop

| Model | GPM | Pressure Drop (psi) | | | | |
|--------|------|---------------------|------|------|-------|-------|
| | | 30°F | 60°F | 80°F | 100°F | 120°F |
| 018R* | 3.0 | 0.5 | 0.4 | 0.4 | 0.3 | 0.3 |
| | 4.0 | 1.1 | 0.9 | 0.9 | 0.8 | 0.8 |
| | 5.0 | 1.6 | 1.4 | 1.4 | 1.3 | 1.3 |
| | 6.0 | 2.1 | 1.9 | 1.9 | 1.8 | 1.8 |
| 025R* | 4.0 | 1.0 | 0.9 | 0.9 | 0.8 | 0.8 |
| | 5.5 | 2.2 | 2.0 | 1.9 | 1.8 | 1.7 |
| | 7.0 | 3.3 | 3.0 | 2.9 | 2.7 | 2.6 |
| 040H/R | 8.5 | 4.8 | 4.5 | 4.4 | 4.2 | 4.1 |
| | 5.0 | 0.9 | 0.6 | 0.6 | 0.5 | 0.5 |
| | 7.5 | 2.3 | 2.1 | 2.0 | 1.9 | 1.8 |
| 050H/R | 10.0 | 3.7 | 3.5 | 3.3 | 3.2 | 3.0 |
| | 12.5 | 5.0 | 4.7 | 4.4 | 4.2 | 4.0 |
| | 8.0 | 1.7 | 1.4 | 1.4 | 1.3 | 1.3 |
| 060H/R | 11.5 | 3.6 | 3.4 | 3.2 | 3.0 | 2.8 |
| | 15.0 | 5.6 | 5.4 | 5.0 | 4.6 | 4.2 |
| | 18.5 | 8.3 | 8.1 | 7.6 | 7.2 | 6.8 |
| | 9.0 | 1.4 | 1.1 | 1.0 | 1.0 | 0.9 |
| 075H/R | 13.5 | 4.2 | 3.9 | 3.5 | 3.1 | 2.7 |
| | 18.0 | 6.9 | 6.7 | 6.0 | 5.2 | 4.5 |
| | 22.5 | 10.7 | 10.5 | 10.0 | 9.4 | 8.7 |
| 075H/R | 10.0 | 3.2 | 3.0 | 2.8 | 2.7 | 2.5 |
| | 14.5 | 5.5 | 5.3 | 5.1 | 4.9 | 4.7 |
| | 19.0 | 7.9 | 7.6 | 7.3 | 7.1 | 6.8 |
| | 23.5 | 11.5 | 11.3 | 11.0 | 10.8 | 10.5 |

NOTES: Temperatures are Entering Water Temperatures 7/13/09
 *Domestic water heating units source side pressure drop and reversible units load and source pressure drop.

NSW Heating Only Load Side

| Model | GPM | Pressure Drop (psi) | | | |
|-------|-----|---------------------|------|-------|-------|
| | | 60°F | 80°F | 100°F | 120°F |
| 018H | 3.0 | 0.5 | 0.4 | 0.4 | 0.3 |
| | 4.0 | 1.4 | 1.3 | 1.2 | 1.2 |
| | 5.0 | 2.2 | 2.1 | 2.1 | 2.0 |
| | 6.0 | 3.0 | 2.9 | 2.9 | 2.8 |
| 025H | 4.0 | 1.3 | 1.3 | 1.2 | 1.2 |
| | 5.5 | 3.0 | 2.9 | 2.8 | 2.7 |
| | 7.0 | 4.6 | 4.4 | 4.3 | 4.1 |
| | 8.5 | 6.7 | 6.5 | 6.4 | 6.2 |

NOTE: Temperatures are Entering Water Temperatures 7/13/09

Operating Limits

| Operating Limits | Cooling | | Heating | |
|---------------------------------|---------|------|---------|------|
| | °F | °C | °F | °C |
| Source Side Water Limits | | | | |
| Minimum Entering Water | 30 | -1.1 | 20 | -6.7 |
| Normal Entering Water | 85 | 29.4 | 60 | 15.6 |
| Maximum Entering Water | 110 | 43.3 | 90 | 32.2 |
| Load Side Water Limits | | | | |
| Minimum Entering Water | 50 | 10.0 | 60 | 15.6 |
| Normal Entering Water | 60 | 15.6 | 100 | 37.8 |
| Maximum Entering Water | 90 | 32.2 | 120 | 48.9 |

NOTES: Minimum/maximum limits are only for start-up conditions, and are meant for bringing the space up to occupancy temperature. Units are not designed to operate at the minimum/maximum conditions on a regular basis. The operating limits are dependant upon three primary factors: 1) entering source temperature, 2) entering load temperature, and 3) flow rate (gpm). When any of the factors are at the minimum or maximum levels, the other two factors must be at the normal level for proper and reliable unit operation. Consult the Capacity Tables for each model to determine allowable normal operating conditions. Units are not designed for outdoor installation.

Heating with High Source Temperatures

Heating water with a water to water unit using high source temperatures can lead to operating conditions that fall outside of the system operating range. The condition occurs when the loop (source) temperature exceeds 70°F [21.1°C] with a full flow of 3 GPM per ton [0.054 LPS per kW]. Under this scenario, the evaporating temperature can fall outside of the compressor operating window.

To allow the system to operate correctly, restricting the source side flow when the evaporating temperature exceeds 55°F [12.7°C] is recommended. One way of accomplishing this is to use a flow-restricting valve on the source loop circuit that is controlled by the evaporating temperature. Locate the sensing device on the refrigerant inlet of the evaporator.

As an alternative to the evaporating temperature, the suction line temperature can be monitored with the same control capability. In this control, temperature should be a maximum of 65°F [18.3°C].

Physical Data

| Model | 018 | 025 | 040 | 050 | 060 | 075 |
|--------------------------------------|-------------|-------------|-------------|-------------|-------------|-------------|
| Compressor (1 each) | Scroll | | | | | |
| Factory Charge R410a, oz [kg] | 44.0 [1.25] | 54.0 [1.53] | 62 [1.76] | 68 [1.93] | 104 [2.95] | 110 [3.12] |
| Coax & Piping Water Volume - gal [l] | .52 [1.97] | .89 [3.38] | 1.0 [3.94] | 1.4 [5.25] | 1.6 [6.13] | 1.6 [6.13] |
| Weight - Operating, lb [kg] | 191 [86.6] | 225 [102.1] | 290 [131.5] | 325 [147.4] | 345 [156.5] | 345 [156.5] |
| Weight - Packaged, lb [kg] | 206 [93.4] | 240 [108.9] | 305 [138.3] | 340 [154.2] | 360 [163.3] | 360 [163.3] |

6/29/09

Flow Rates

Source Flow Rates

| Model | Minimum Open Loop Flow Rate | Minimum Closed Loop Flow Rate | Normal Load Flow Rate | Maximum Flow Rate |
|-------|-----------------------------|-------------------------------|-----------------------|-------------------|
| 018 | 3.0 | 4.0 | 5.0 | 7.0 |
| 025 | 4.0 | 5.0 | 7.0 | 9.0 |
| 040 | 5.0 | 8.0 | 10.0 | 12.0 |
| 050 | 8.0 | 12.0 | 15.0 | 17.0 |
| 060 | 9.0 | 13.0 | 18.0 | 20.0 |
| 075 | 10.0 | 14.0 | 19.0 | 21.0 |

5/15/09

Load Flow Rates

| Model | Minimum Load Flow Rate | Normal Load Flow Rate | Maximum Flow Rate |
|-------|------------------------|-----------------------|-------------------|
| 018 | 3.0 | 5.0 | 7.0 |
| 025 | 4.0 | 7.0 | 9.0 |
| 040 | 5.0 | 10.0 | 12.0 |
| 050 | 8.0 | 15.0 | 17.0 |
| 060 | 9.0 | 18.0 | 20.0 |
| 075 | 10.0 | 19.0 | 21.0 |

5/15/09

Troubleshooting

Should a major problem develop, refer to the following information for possible causes and corrective steps:

Compressor Won't Run

1. The fuse may be blown or the circuit breaker is open. Check electrical circuits and motor windings for shorts or grounds. Investigate for possible overloading. Replace fuse or reset circuit breakers after the fault is corrected.
2. Supply voltage may be too low. Check voltage with a volt meter.
3. Remote control system may be faulty. Check aquastat for correct wiring, setting and calibration. Check 24-volt transformer for burnout.
4. Wires may be loose or broken. Replace or tighten.
5. The low pressure switch may have tripped due to one or more of the following:
 - a. Fouled or plugged coaxial heat exchangers
 - b. Low or no water flow (source side heating, load side cooling)
 - c. Water too cold (source side heating)
 - d. Low refrigerant
6. The high pressure switch may have tripped due to one or more of the following:
 - a. Fouled or plugged coaxial heat exchanger
 - b. Low or no water flow (source side cooling, load side heating)
 - c. Water too warm (source side cooling)
7. Check the capacitor.
8. The compressor overload protection may be open. If the compressor dome is extremely hot, the overload will not reset until cooled down. If the overload does not reset when cool, it may be defective. If so, replace the compressor.

9. The internal winding of the compressor motor may be grounded to the compressor shell. If so, replace the compressor.
10. The compressor winding may be open. Check continuity with an ohm meter. If the winding is open, replace the compressor.

Insufficient Cooling or Heating

1. Check aquastat for improper location (secondary mode only).
2. Check for restriction in water flow.
3. Check subcooling for low refrigerant charge.
4. The reversing valve may be defective and creating a bypass of refrigerant. If the unit will not cool, check the reversing valve coil.
5. Check thermal expansion valve for possible restriction of refrigerant flow.

Noisy Unit Operation

1. Check compressor for loosened mounting bolts. Make sure compressor is floating free on its isolator mounts.
2. Check for tubing contact with the compressor or other surfaces. Readjust it by bending slightly.
3. Check screws on all panels.
4. Check for chattering or humming in the contactor or relays due to low voltage or a defective holding coil. Replace the component.
5. Check for proper installation of vibration absorbing material under the unit. Unit must be fully supported, not just on corners.
6. Check for abnormally high discharge pressures.

Troubleshooting cont.

Troubleshooting Controls

Check the unit. If a lockout mode is displayed, refer to the table below to determine the meaning of the failure. Follow the procedure listed to correct the problem.

Check the mode:

1. If the unit is running on the internal aquastat, verify the unit is in "Primary" mode. The SL should be set to 0 in the setup menu.
2. If the unit is running on an external aquastat, the SL should be set to 1.

Check the jumpers on the control board:

1. Refer to the Control Board with Jumper illustration in the Converting to a Dedicated Cooling Unit section to see the location of the jumper on the board. If the unit is a heating only unit, the jumper should be across 1 and 2.
2. If the unit is a cooling only unit, the jumper should be across 2 and 3.
3. If the unit is a reversible unit, the jumper should be across 3 and 4.

Check the thermistor calibration:

1. Using a thermometer in the P/T port, check the incoming water temperature.
2. Verify that the measured temperature is within 3 degrees of the temperature displayed on the unit.
3. If it is not, adjust the calibration in the setup menu.

Standard Control Diagnostic Table

| DISPLAY | FAILURE | DIAGNOSTIC |
|---------|---|---|
| DC | Freeze detection thermistor is closed (shorted) | Replace the freeze detection thermistor (clip-on thermistor) |
| DO | Freeze detection thermistor is open | Verify that the freeze detection thermistor is secured properly in the board connector. If the connection is secure, replace the thermistor. |
| FP | Freeze detection | The water going through the unit has reached the freeze point setting (P=5, CL=15, OL=30). Verify that the freeze detection setting is correct for the application. |
| HC | Water set point thermistor is closed (shorted) | Replace the water set point thermistor (threaded thermistor). |
| HP | High Pressure | The unit has cut out on high pressure. Discharge pressure is >600. |
| LP | Low Pressure | The unit has cut out on low pressure. Suction pressure is <40 |
| PO | Water set point thermistor is open | Verify that the water set point thermistor is properly secured in the board connector. If the connection is secure, replace the thermistor. |

1

Operating Parameters

Heating Mode

| Entering Load Temp (°F) | Entering Source Temp (°F) | Suction Pressure (psig) | Discharge Pressure (psig) | Superheat (°F) | Subcooling (°F) |
|-------------------------|---------------------------|---------------------------|---------------------------|----------------|-----------------|
| 60 | 20 | 52-67 | 195-227 | 8-16 | 5-15 |
| | 30 | 67-82 | 208-235 | 7-14 | 6-14 |
| | 50 | 95-113 | 216-245 | 7-14 | 6-12 |
| | 70 | 124-144 | 225-255 | 8-19 | 5-15 |
| | 90 | 143-167 | 230-275 | 14-26 | 8-12 |
| 80 | 20 | 54-69 | 283-316 | 8-16 | 7-15 |
| | 30 | 69-84 | 293-323 | 10-12 | 7-18 |
| | 50 | 98-125 | 302-335 | 12-14 | 8-16 |
| | 70 | 121-148 | 311-346 | 14-18 | 8-16 |
| | 90 | 144-179 | 319-363 | 14-26 | 8-16 |
| 100 | 20 | 56-71 | 369-405 | 8-10 | 6-14 |
| | 30 | 77-85 | 378-411 | 10-12 | 7-15 |
| | 50 | 64-126 | 388-425 | 12-14 | 7-15 |
| | 70 | 123-152 | 398-438 | 14-18 | 3-12 |
| | 90 | 148-191 | 408-452 | 14-22 | 3-12 |
| 120 | 20 | 59-74 | 455-495 | 8-18 | 4-16 |
| | 30 | 74-87 | 464-500 | 6-16 | 5-17 |
| | 50 | 106-128 | 474-515 | 5-17 | 5-15 |
| | 70 | 125-156 | 485-530 | 6-16 | 4-15 |
| | 90 | Operation not recommended | | | |

NOTES: Operating parameters at 3 gpm/ton source and load flow. Consult the Capacity Tables for each NSW model for normal allowable operating conditions. Some of the conditions shown above are outside of the compressor operational limits for specific models.

Cooling Mode

| Entering Load Temp (°F) | Entering Source Temp (°F) | Suction Pressure (psig) | Discharge Pressure (psig) | Superheat (°F) | Subcooling (°F) |
|-------------------------|---------------------------|---------------------------|---------------------------|----------------|-----------------|
| 50 | 30 | 86-99 | 135-160 | 12-22 | 2-15 |
| | 50 | 92-107 | 191-214 | 10-19 | 4-15 |
| | 70 | 98-115 | 248-268 | 5-15 | 6-16 |
| | 90 | 101-119 | 335-367 | 6-15 | 8-16 |
| | 110 | 105-122 | 425-465 | 8-16 | 10-19 |
| 70 | 30 | 89-106 | 131-163 | 15-20 | 3-6 |
| | 50 | 103-125 | 194-223 | 11-15 | 6-9 |
| | 70 | 118-143 | 257-273 | 11-15 | 9-12 |
| | 90 | 125-151 | 344-381 | 8-12 | 12-14 |
| 90 | 30 | 92-113 | 128-166 | 15-20 | 3-6 |
| | 50 | 115-143 | 197-233 | 11-15 | 6-9 |
| | 70 | 129-158 | 266-294 | 11-15 | 9-12 |
| | 90 | 150-168 | 354-395 | 8-12 | 12-14 |
| 110 | 30 | 96-121 | 125-170 | 55-65 | 2-20 |
| | 50 | 127-161 | 200-243 | 41-52 | 4-18 |
| | 70 | 158-200 | 275-315 | 21-38 | 8-19 |
| | 90 | Operation not recommended | | | |

NOTES: Operating parameters at 3 gpm/ton source and load flow. Consult the Capacity Tables for each NSW model for normal allowable operating conditions. Some of the conditions shown above are outside of the compressor operational limits for specific models.

6/16/09

Heating Cycle Analysis

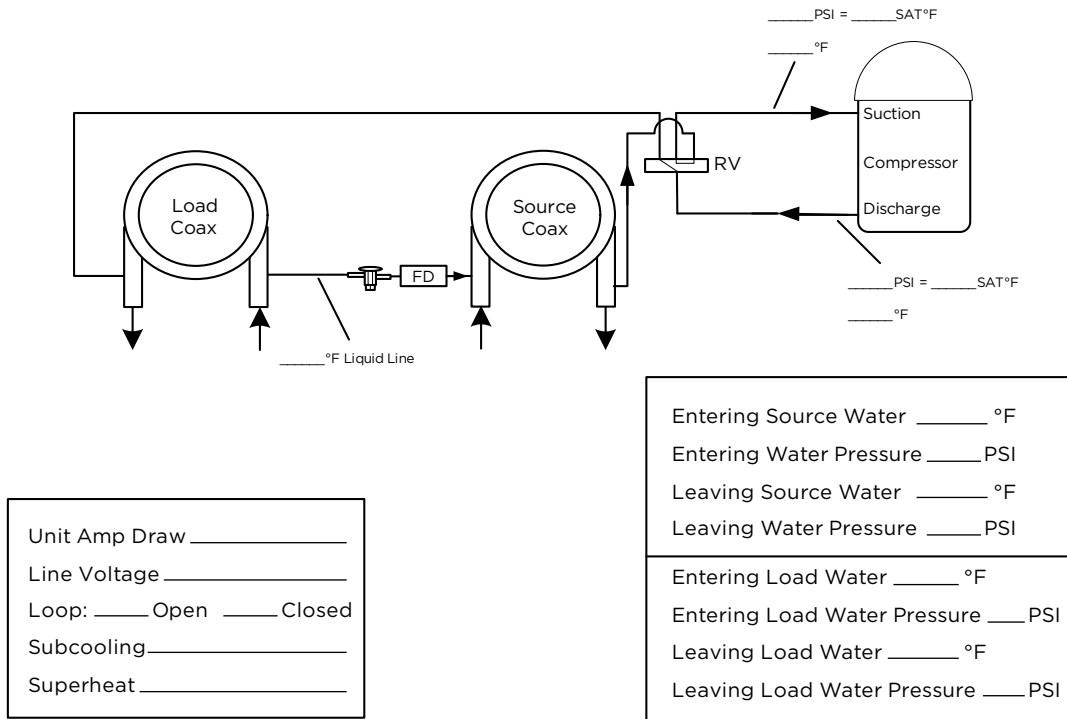

NOTE: Do not attach refrigerant gauges unless a problem is suspected!

Cooling Cycle Analysis

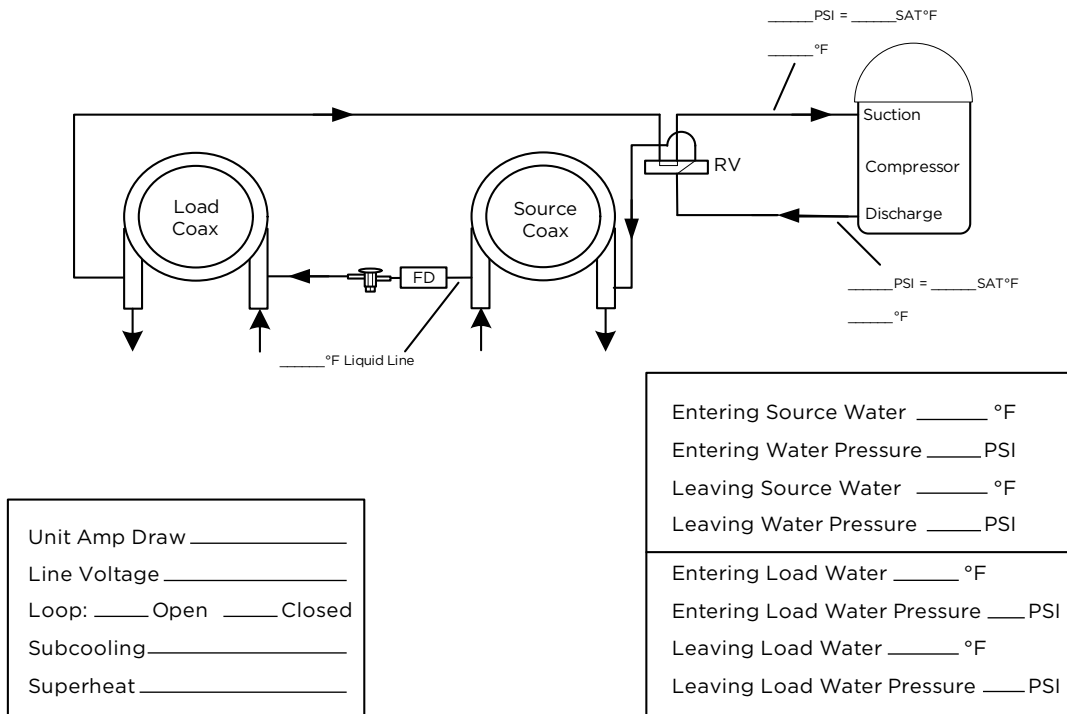

NOTE: Do not attach refrigerant gauges unless a problem is suspected!

Envision NSW Startup and Troubleshooting Form

Company Name: _____ Company Phone No: _____
 Technician Name: _____ Date: _____
 Model No: _____ Serial No: _____
 Owner's Name: _____ Open or Closed Loop: _____
 Installation Address: _____ Installation Date: _____

Check One

Start up/Check-out for new installation Troubleshooting Problem: _____

1. FLOW RATE IN GPM (SOURCE SIDE HEAT EXCHANGER)

Water In Pressure: a. _____ PSI
 Water Out Pressure: b. _____ PSI
 Pressure Drop = a - b c. _____ PSI
 Convert Pressure Drop to Flow Rate
 (refer to *Pressure Drop* table) d. _____ GPM

2. TEMPERATURE RISE OR DROP ACROSS SOURCE SIDE HEAT EXCHANGER

| | COOLING | HEATING |
|-------------------------|-------------|-------------|
| Water In Temperature: | e. _____ °F | e. _____ °F |
| Water Out Temperature: | f. _____ °F | f. _____ °F |
| Temperature Difference: | g. _____ °F | g. _____ °F |

3. TEMPERATURE RISE OR DROP ACROSS LOAD SIDE HEAT EXCHANGER

| | COOLING | HEATING |
|-------------------------|-------------|-------------|
| Water In Temperature: | h. _____ °F | h. _____ °F |
| Water Out Temperature: | i. _____ °F | i. _____ °F |
| Temperature Difference: | j. _____ °F | j. _____ °F |

4. HEAT OF REJECTION (HR) / HEAT OF EXTRACTION (HE) CALCULATION

HR or HE = Flow Rate x Temperature Difference x Brine Factor*
 d. (above) x g. (above) x 485 for Methanol or Environol, 500 for water*
 Heat of Extraction (Heating Mode) = _____ btu/hr
 Heat of Rejection (Cooling Mode) = _____ btu/hr
 Compare results to Capacity Data Tables

Note: Steps 5 through 8 need only be completed if a problem is suspected

5. WATTS

| | COOLING | HEATING | HYDRONIC |
|---------------------------|----------------|----------------|----------------|
| Volts: | m. _____ VOLTS | m. _____ VOLTS | m. _____ VOLTS |
| Total Amps (Comp. + Fan): | n. _____ AMPS | n. _____ AMPS | n. _____ AMPS |
| Watts = m. x n. x 0.85 | o. _____ WATTS | o. _____ WATTS | o. _____ WATTS |

6. CAPACITY

Cooling Capacity = HR. - (o. x 3.413) p. _____ btu/hr
 Heating Capacity = HE. + (o. x 3.413) p. _____ btu/hr

7. EFFICIENCY

Cooling EER = p. / o. q. _____ EER
 Heating COP = p. / (o. x 3.413) q. _____ COP

8. SUPERHEAT (S.H.) / SUBCOOLING (S.C.)

| | COOLING | HEATING | HYDRONIC |
|---------------------------------|--------------|--------------|--------------|
| Suction Pressure: | r. _____ PSI | r. _____ PSI | r. _____ PSI |
| Suction Saturation Temperature: | s. _____ °F | s. _____ °F | s. _____ °F |
| Suction Line Temperature: | t. _____ °F | t. _____ °F | t. _____ °F |
| Superheat = t. - s. | u. _____ °F | u. _____ °F | u. _____ °F |
| Head Pressure: | v. _____ PSI | v. _____ PSI | v. _____ PSI |
| High Pressure Saturation Temp.: | w. _____ °F | w. _____ °F | w. _____ °F |
| Liquid Line Temperature*: | x. _____ °F | x. _____ °F | x. _____ °F |
| Subcooling = w. - x. | y. _____ °F | y. _____ °F | y. _____ °F |

* Note: Liquid line is between the source heat exchanger and the expansion valve in the cooling mode; between the load heat exchanger and the expansion valve in the heating mode.

Reference Calculations

| | |
|--|--|
| <p>Heating Calculations:</p> $\text{LWT} = \text{EWT} - \frac{\text{HE}}{\text{GPM} \times \text{C}^*}$ $\text{HE} = \text{C}^* \times \text{GPM} \times (\text{EWT} - \text{LWT})$ | <p>Cooling Calculations:</p> $\text{LWT} = \text{EWT} + \frac{\text{HR}}{\text{GPM} \times \text{C}^*}$ $\text{HR} = \text{C}^* \times \text{GPM} \times (\text{LWT} - \text{EWT})$ |
|--|--|

NOTE: * C = 500 for pure water, 485 for brine.

Legends and Notes

Abbreviations and Definitions

| | |
|---|---|
| ELT = entering load fluid temperature to heat pump | kW = kilowatts |
| SWPD = source coax water pressure drop | EST = entering source fluid temperature to heat pump |
| LLT = leaving load fluid temperature from heat pump | HE = heat extracted in MBTUH |
| PSI = pressure drop in pounds per square inch | LST = leaving source fluid temperature from heat pump |
| LGPM = load flow in gallons per minute | HC = total heating capacity in MBTUH |
| FT HD = pressure drop in feet of head | COP = coefficient of performance, heating [HC/kW x 3.413] |
| LWPD = load coax water pressure drop | EER = energy efficiency ratio, cooling |
| LWT = leaving water temperature | TC = total cooling capacity in MBTUH |
| EWT = entering water temperature | HR = heat rejected in MBTUH |
| Brine = water with a freeze inhibiting solution | |

Notes to Performance Data Tables

The following notes apply to all performance data tables:

- Three flow rates are shown for each unit. The lowest flow rate shown is used for geothermal open loop/well water systems with a minimum of 50°F EST. The middle flow rate shown is the minimum geothermal closed loop flow rate. The highest flow rate shown is optimum for geothermal closed loop systems and the suggested flow rate for boiler/tower applications.
- Entering water temperatures below 40°F assumes 15% antifreeze solution.
- Interpolation between ELT, EST, and GPM data is permissible.
- Operation in the gray areas is not recommended.

Antifreeze Correction

Catalog performance can be corrected for antifreeze use. Please use the following table and note the example given.

| Antifreeze Type | Antifreeze % by wt | Heating | | Cooling | | Pressure Drop |
|-------------------------|-----------------------|------------------|------------------|------------------|------------------|------------------|
| | | Load | Source | Load | Source | |
| EWT - °F [°C] | | 80 [26.7] | 30 [-1.1] | 50 [10.0] | 90 [32.2] | 30 [-1.1] |
| Water | 0 | 1.000 | 1.000 | 1.000 | 1.000 | 1.000 |
| Ethylene Glycol | 10 | 0.990 | 0.973 | 0.976 | 0.991 | 1.075 |
| | 20 | 0.978 | 0.943 | 0.947 | 0.979 | 1.163 |
| | 30 | 0.964 | 0.917 | 0.921 | 0.965 | 1.225 |
| | 40 | 0.953 | 0.890 | 0.897 | 0.955 | 1.324 |
| | 50 | 0.942 | 0.865 | 0.872 | 0.943 | 1.419 |
| Propylene Glycol | 10 | 0.981 | 0.958 | 0.959 | 0.981 | 1.130 |
| | 20 | 0.967 | 0.913 | 0.921 | 0.969 | 1.270 |
| | 30 | 0.946 | 0.854 | 0.869 | 0.950 | 1.433 |
| | 40 | 0.932 | 0.813 | 0.834 | 0.937 | 1.614 |
| | 50 | 0.915 | 0.770 | 0.796 | 0.922 | 1.816 |
| Ethanol | 10 | 0.986 | 0.927 | 0.945 | 0.991 | 1.242 |
| | 20 | 0.967 | 0.887 | 0.906 | 0.972 | 1.343 |
| | 30 | 0.944 | 0.856 | 0.869 | 0.947 | 1.383 |
| | 40 | 0.926 | 0.815 | 0.830 | 0.930 | 1.523 |
| | 50 | 0.907 | 0.779 | 0.795 | 0.911 | 1.639 |
| Methanol | 10 | 0.985 | 0.957 | 0.962 | 0.986 | 1.127 |
| | 20 | 0.969 | 0.924 | 0.929 | 0.970 | 1.197 |
| | 30 | 0.950 | 0.895 | 0.897 | 0.951 | 1.235 |
| | 40 | 0.935 | 0.863 | 0.866 | 0.936 | 1.323 |
| | 50 | 0.919 | 0.833 | 0.836 | 0.920 | 1.399 |



WARNING: Gray area represents antifreeze concentrations greater than 35% by weight and should be avoided due to the extreme performance penalty they represent.

Antifreeze Correction Example

Antifreeze solution is propylene glycol 20% by weight for the source and methanol 10% for the load. Determine the corrected heating at 30°F source and 80°F load as well as pressure drop at 30°F for an Envision Series NSW050. Also, determine the corrected cooling at 90°F source and 50°F load.

The corrected heating capacity at 30°F/80°F would be:

$$46,700 \text{ MBTUH} \times 0.913 \times 0.985 = 41,998 \text{ MBTUH}$$

The corrected cooling capacity at 90°F/50°F would be:

$$44,200 \times 0.969 \times 0.962 = 41,202 \text{ MBTUH}$$

The corrected pressure drop at 30°F and 15 GPM would be:

$$5.2 \text{ psi} \times 1.270 = 6.60 \text{ psi}$$

Preventive Maintenance

1. Keep all air out of the water lines. An open loop system should be checked to ensure that the well head is not allowing air to infiltrate the water line. Lines should always be airtight.
2. Keep the system under pressure at all times. In open loop systems, it is recommended that a water control valve be placed in the discharge line to prevent loss of pressure during off cycles. Closed loop systems must have a positive static pressure.

NOTES: If the installation is performed in an area with a known high mineral content in the water, it is best to establish a periodic maintenance schedule to check the water-to-refrigerant heat exchanger on a regular basis. Should periodic cleaning be necessary, use standard cleaning procedures which are compatible with either the cupronickel or copper water lines. Generally, the more water flowing through the unit, the less chance there is for scaling. Low GPM flow rates produce higher temperatures through the coil. To avoid excessive pressure drop and the possibility of copper erosion, do not exceed GPM flow rate as shown on the specification sheets for each unit.

Cleaning Procedure

1. Close the inlet and outlet water valves to isolate the heat pump from the well system, water heater or loop pumps.
2. Disconnect piping and remove solenoid valve, pumps, etc, from the inlet and outlet connections on the heat pump.
3. Connect plastic hoses from the circulating pump* to the outlet of the water-to-refrigerant heat exchanger to be de-limed (refer to the Cleaning Connections illustration).
4. Connect a plastic hose from the circulating pump inlet to the bottom of a plastic five (5) gallon pail (refer to the Cleaning Connections illustration).
5. Connect a plastic hose from the inlet line of the water-to-refrigerant heat exchanger to the plastic pail. Secure tightly to ensure that circulating solution does not spill (refer to the Cleaning Connections illustration).
6. Partially fill the plastic pail with clear water (about two-thirds full) and prime the circulating pump. Circulate until lines are full.
7. Start the circulating pump and slowly add a commercial scale remover** to the water as recommended by the scale remover manufacturer's directions.
8. Be sure the pump circulation is opposite to the normal water flow through the water-to-refrigerant heat exchanger.
9. Maintain re-circulation until all scale and other material has been dissolved and flushed from the heat exchanger.
10. Upon completion of the procedure. Safely dispose of the solution.
11. Rinse the pump and plastic pail. Refill with clear water.
12. Start the pump circulation and flush the system until all acid residue has been removed from the system. Refill the plastic pail until only clear water is circulated.
13. Turn off the circulating pump and disconnect all hoses and fittings.
14. Replace solenoid valves, pumps, hoses and other devices in their original locations. On closed loop systems, be sure to purge between the flow center and unit to avoid getting air into the loop.
15. Put the heat pump back into operation. Check for proper operating temperature.

Cleaning Connections

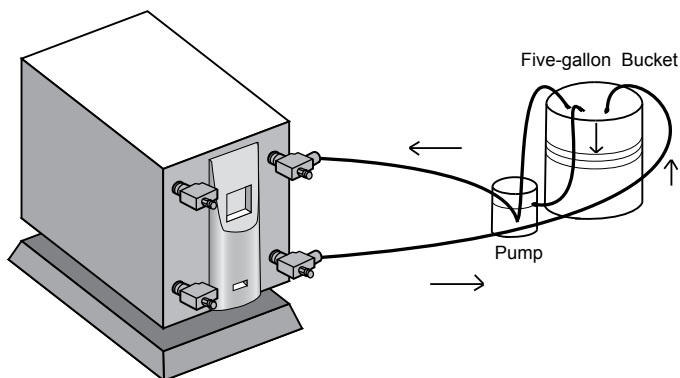

WARNING: This process involves a caustic solution and may be harmful to people and animals. Wear protective equipment (glasses, rubber gloves, apron, etc.)

NOTES: *Virginia Chemical Co. makes a Pump model H460.

* W.W. Granger Co. sells a Pump #2P-017 made by Little Giant.

**Virginia Chemical Co. makes a liquid ice machine cleaner which should be used on water-to-refrigerant heat exchangers serving a domestic hot water system. Calci-Solve by NYCO is available for use on other heat exchangers

Service Parts

| Part Description | | 018 | 025 | 040 | 050 | 060 | 075 |
|--------------------------|---|----------------------|--------------|--------------|--------------|--------------|--------------|
| | | 208-230/60/1 | 208-230/60/1 | 208-230/60/1 | 208-230/60/1 | 208-230/60/1 | 208-230/60/1 |
| Refrigeration Components | Compressor | 34P622-01 | 34P568-05 | 34P621-01 | 34P580-01 | 34P616-01 | 34P614-01 |
| | Compressor Capacitor | 16P002D20 | 16P002D20 | 16P002D36 | 16P002D25 | 16P002D39 | 16P002D39 |
| | Compressor Sound Jacket | 92P504A05 | 92P504A05 | 92P519-01 | 92P519-02 | 92P519-02 | 92P519-02 |
| | Thermal Expansion Valve | 33P605-16 | 33P605-18 | 33P605-10 | 33P605-15 | 33P605-17 | 33P605-17 |
| | Filter Drier for 'Reversible Models' | 36P500B01 | 36P500B01 | 36P500B01 | 36P500B02 | 36P500B02 | 36P500B02 |
| | Filter Drier for 'Heating Only' Models | 36P510-01 | | | | | |
| | Reversing Valve with Coil | 33P506-04 | 33P506-04 | 33P503-05 | 33P526-04 | 33P526-04 | 33P526-04 |
| | Hot Water Generator (Desuperheater) | n/a | n/a | 62I516-03 | 62I516-03 | 62I516-03 | 62I516-03 |
| | Source Coaxial Heat Exchanger (copper) | 62I566-01 | 62I534-04 | 62I535-04 | 62I543-04 | 62I557-01 | 62I557-01 |
| | Source Coaxial Heat Exchanger (cupronickel) | 62I566-02 | 62I534-03 | 62I535-03 | 62I543-03 | 62I557-02 | 62I557-02 |
| | Load Coaxial Heat Exchanger (copper) | 62I566-01 | 62I534-04 | 62I535-04 | 62I543-04 | 62I557-01 | 62I557-01 |
| | Load Coaxial Heat Exchanger (cupronickel) | 62I566-02 | 62I534-03 | 62I535-03 | 62I543-03 | 62I557-02 | 62I557-02 |
| | DHW Load Coax Vented Double Wall (copper) | 62P567-01 | 62P549-01 | n/a | n/a | n/a | n/a |
| | Safeties / Sensors | High Pressure Switch | 35P506B02 | 35P506B02 | 35P506B02 | 35P506B02 | 35P506B02 |
| Low Pressure Switch | | 35P506B01 | 35P506B01 | 35P506B01 | 35P506B01 | 35P506B01 | 35P506B01 |
| Water Temperature Sensor | | 12P541-01 | 12P541-01 | 12P541-01 | 12P541-01 | 12P541-01 | 12P541-01 |
| Freeze Detection Sensor | | 12P505-05 | 12P505-05 | 12P505-05 | 12P505-05 | 12P505-05 | 12P505-05 |
| Electrical | Compressor Contactor | 13P004A03 | 13P004A03 | 13P004A03 | 13P004A03 | 13P004A03 | 13P004A03 |
| | Transformer | 15P501-02 | 15P501-02 | 15P501-02 | 15P501-02 | 15P501-02 | 15P501-02 |
| | Load Pump Relay and/or Status Input | 13P003-02 | 13P003-02 | 13P003-02 | 13P003-02 | 13P003-02 | 13P003-02 |
| | Connection Block - 3 Position | 12P503-06 | 12P503-06 | 12P503-06 | 12P503-06 | 12P503-06 | 12P503-06 |
| | Connection Block - 12 Position | 12P503-07 | 12P503-07 | 12P503-07 | 12P503-07 | 12P503-07 | 12P503-07 |
| | Connection Block - 12 Position Double Tab | 12P528B01 | 12P528B01 | 12P528B01 | 12P528B01 | 12P528B01 | 12P528B01 |
| | Fuse Power Block | 12P539-01 | 12P539-01 | 12P539-01 | 12P539-01 | 12P539-01 | 12P539-01 |
| | Fuse 1-1/4 3AB Normal Blow 10 Amp | 19P502A01 | 19P502A01 | 19P502A01 | 19P502A01 | 19P502A01 | 19P502A01 |
| | Control Touch Screen | 19S561-02 | 19S561-02 | 19S561-02 | 19S561-02 | 19S561-02 | 19S561-02 |
| | Control Board | 17P549-04 | 17P549-04 | 17P549-04 | 17P549-04 | 17P549-04 | 17P549-04 |
| | IntelliStart Soft Starter | IS060S | IS060S | IS060S | IS060L | IS060L | IS060L |
| | IntelliStart Power Block | 12P546-01 | 12P546-01 | 12P546-01 | 12P546-01 | 12P546-01 | 12P546-01 |
| | Grounding Lug | 12P004A | 12P004A | 12P004A | 12P004A | 12P004A | 12P004A |
| Cabinet | Rear Access Panel | 40F749-10 | 40F749-10 | 40F749-10 | 40F749-10 | 40F749-10 | 40F749-10 |
| | Front Plastic Access Panel | 40P542-50 | 40P542-50 | 40P542-50 | 40P542-50 | 40P542-50 | 40P542-50 |
| | Top Panel | 42C549-01 | 42C549-01 | 42C548-01 | 42C548-01 | 42C548-01 | 42C548-01 |

7/15/09



Manufactured by
WaterFurnace International, Inc.
9000 Conservation Way
Fort Wayne, IN 46809
www.waterfurnace.com



| | |
|-----------|-------------------------------|
| Product: | Envision Series NSW |
| Type: | Geothermal Hydronic Heat Pump |
| Size: | 1.5-6 Tons |
| Document: | Installation Manual |